

INSTALLATION INSTRUCTIONS

VISATRON® Oil Mist Detection System

VN301^{plus} / VN301^{plus} EX / VN301^{plus} light / EX light

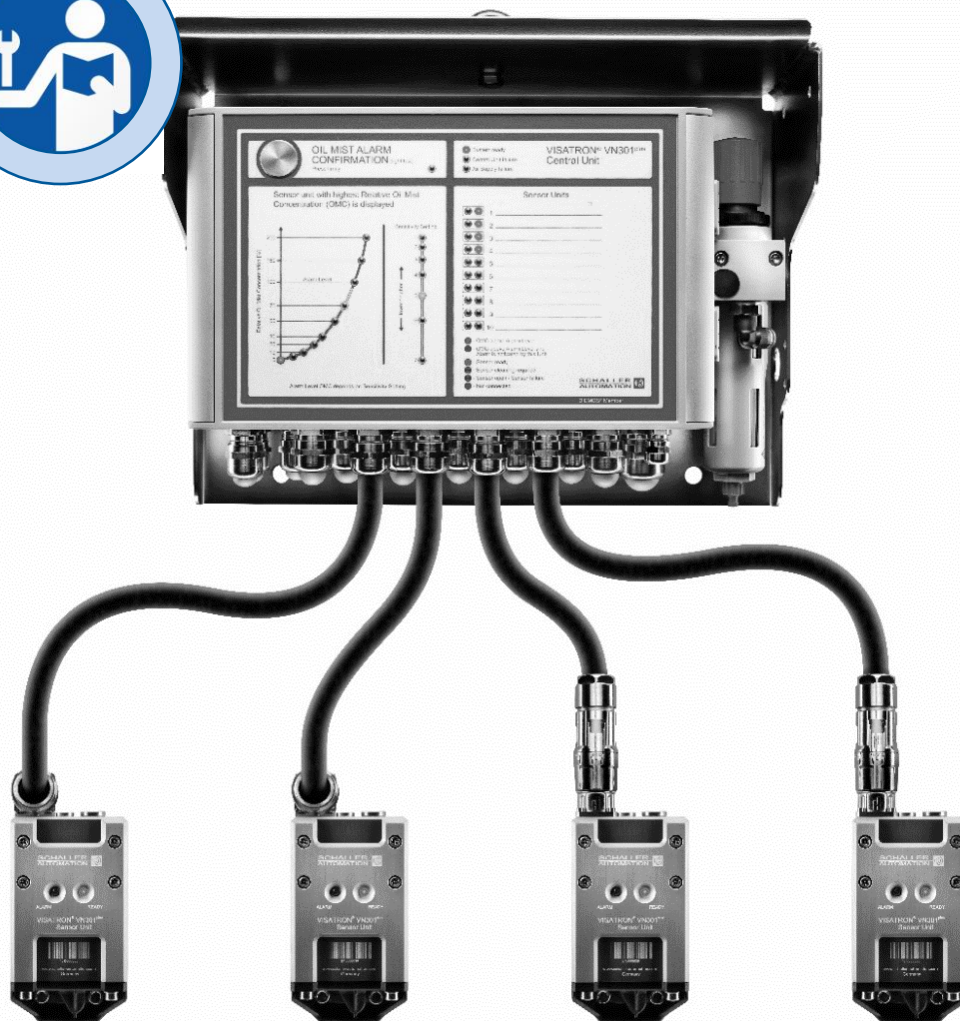

Version date: 14/07/2025
Version: Version 1.3
Document No.: Part number 180543

The original installation instructions are written in German.
 Any translations are based on the original installation instructions.



LEGAL NOTICE

The installation instructions apply to the following products:

- VISATRON[®] VN301^{plus}
- VISATRON[®] VN301^{plus} EX
- VISATRON[®] VN301^{plus} light
- VISATRON[®] VN301^{plus} EX light

Firmware version of the “Central Unit” at the time of publication:
V1.21 dated 24/04/2020

Copyright

This manual is protected by copyright. All rights are reserved.

We reserve the right to make technical changes to the hardware and software of our VISATRON[®] products without prior notice. We do not assume any liability a currently delivered device having all the features described in these installation instructions.

The reproduction, translation, microfilming and the storage and processing of this manual, including in part, is only allowed with the consent of Schaller Automation Industrielle Automationstechnik GmbH & Co. KG.

Any infringement shall attract damages and may have consequences under criminal law. Specifications of nominal conditions, technical changes, improvements and errors are excepted.

These installation instructions may only be passed on to third parties in conjunction with the transfer of the relevant VISATRON[®] device.

Copyright © 2025

Schaller Automation Industrielle Automationstechnik GmbH & Co. KG
Industriering 14
66440 Blieskastel Saarland
Germany

Phone: +49 6842- 508- 0
Fax: +49 6842- 508- 260

Email: info@schaller.de
Website: www.schaller-automation.com

VERSION HISTORY AND CHANGE NOTES

Version	Change	Date	Author
1.0	First version	01/03/2023	J. Wahl
1.1	<ul style="list-style-type: none"> • Layout updated/customised • Text blocks updated/adapted • Amended/added/new sections: <ul style="list-style-type: none"> – Section 1.1 -> New – Section 1.3 -> New – Section 1.4 -> New – Section 1.5 -> Added to – Section 1.6 -> New – Section 2.1 -> Added to – Section 2.2 -> New – Section 2.4 -> Added to – Section 3.0 -> Added to – Section 3.1.3 b) -> Added to 	24/01/2024	J. Wahl
1.2	<ul style="list-style-type: none"> • Added Subsection “c)” to Section 3.1.3. (Alternative assembly of single wires of the hybrid cable with the crimping process) • Section 3.1.4 -> added as new section • Spelling corrections and cleaning up of various sections. 	06/12/2024	J. Wahl
1.3	<ul style="list-style-type: none"> • Layout updated/customised • Spelling corrections and cleaning up of various sections. • Section 3.1.3: Central unit not using all the connections added to part a) • Section 3.1.3: Part b) lengths (steps 2-3) changed • Section 3.1.3: Added torque to part d) Step 3) • Section 3.1.4: Additional content inserted • Section 3.1.5: inserted as new section: Replacing the hybrid connector on the hybrid cable 	14/07/2025	J. Wahl

Table 1: Version history and change notes

Table of contents

1	Information about the installation instructions	5
1.1	Symbols in these installation instructions.....	5
1.2	Validity of the installation instructions.....	5
1.3	Purpose of the installation instructions.....	5
1.4	Document storage	5
1.5	Applicable documents and regulations	6
1.6	Digital installation instructions (online installation instructions).....	6
1.7	Variables and units of measurement that are used.....	6
2	Safety instructions	7
2.1	Hazard levels in warnings	7
2.2	Important information about retrofitting or converting engines.....	7
2.3	Information, warning and mandatory signs that are used	8
2.4	General safety instructions	9
2.4.1	Safety instructions for potentially explosive atmospheres	11
3	Assembly and installation	12
3.1	Hybrid cable.....	12
3.1.1	Installing cable.....	12
3.1.2	Assembly	13
3.1.3	Installing the hybrid cable on the VN301 ^{plus} central unit.....	15
3.1.4	Important note on installing the hybrid connector to the VN301 ^{plus} sensor unit	31
3.1.5	Replacing the hybrid connector on the hybrid cable	32
3.2	Establishing the compressed air supply provided by the customer	36
3.3	Installation space and dimensions for the VN301 ^{plus} sensor unit	37
3.3.1	Installation space and dimensions for the “Horizontal” VN301 ^{plus} sensor unit	37
3.3.2	Installation space and dimensions for the “Vertical” VN301 ^{plus} sensor unit	38
3.3.3	Installation space and dimensions for the “Left” VN301 ^{plus} sensor unit	39
3.3.4	Installation position for the VN301 ^{plus} sensor unit.....	40
3.4	Installation space and dimensions for the VN301 ^{plus} central unit	41
4	Contact	42
5	Notes	43
6	Customer information	44

1 Information about the installation instructions

These instructions are original installation instructions based on EC Directive 2006/42/EC and are structured with text and images. They contain important information about installation of the product, in particular the safety instructions and warnings.

Please read the instructions carefully, then keep them in a safe place!

1.1 Symbols in these installation instructions

Various types of notation and symbols are used in the text of this manual. They are used as follows:

Numbered steps:

- ▶ Required action
 - Result of the sequence of actions
- Symbol for a list
 1. Points of the list

⇒ Reference to a section or figure

Display text



Additional information and instructions



Environmental and energy-saving tips



Different warning symbols are used for warnings. Please see the descriptions and instructions in Section ⇒ . *Section 2 Safety instructions*

1.2 Validity of the installation instructions

These installation instructions apply to the following products:

- VISATRON[®] VN301^{plus}
- VISATRON[®] VN301^{plus} EX
- VISATRON[®] VN301^{plus} light
- VISATRON[®] VN301^{plus} EX light

hereafter referred to as the “device”.

1.3 Purpose of the installation instructions

These installation instructions supplement the currently valid version of the operating manual (Document/Part Number 180101, 180116) with regard to the section “Assembly and installation” by adding further topics or details to existing installation steps.

1.4 Document storage

- ▶ This manual, as well as all other applicable documents, must be kept in a central place so that they are always available to the qualified personnel at the place of use.
- ▶ The documents must be handed over in full to subsequent owners.

1.5 Applicable documents and regulations

Further documents apply and must be observed in conjunction with these installation instructions:

- ▶ **VISATRON® VN301^{plus} / VN301^{plus} EX** operating manual, in the currently valid version (Document No.: Part No. 180101)
- ▶ **VISATRON® VN301^{plus} light / VN301^{plus} EX light** operating manual, in the currently valid version (Document No.: Part No. 180116)
- ▶ User manual for VISATRON® VN301^{plus} “**end-user software**”, currently valid version (Document No.: Part Number 180104_EN, available on the supplied DVD)
- ▶ User manual for VISATRON® VN301^{plus} light “**end-user software**”, currently valid version (Document No.: Part Number 180117_EN, available on the supplied DVD)
- ▶ For additional components, the manuals supplied with them must be observed.

1.6 Digital installation instructions (online installation instructions)

The current version of these installation instructions is also available online and can be accessed at any time. You can find the manual under:

[Installation instructions | Schaller Automation \(schaller-automation.com\)](https://www.schaller-automation.com)

To access the manual, select the manual for your product on our online portal and then start downloading by clicking the  icon. The document then opens automatically in your browser.

1.7 Variables and units of measurement that are used

The following table lists the variables and units of measurement that are currently used in the installation instructions. We reserve the right to add to or change the table, as necessary.







Variable	Unit
Lengths	mm, m
Volume	m ³ , l
Standard volume flow, according to DIN 1343 [at 1013 mbar and 273.15 K (0 °C)]	Nm ³ /h, Nm ³ /min, Nm ³ /s
Volume flow	l/min, m ³ /min, l/h, m ³ /h
Mass	g, kg
Temperature	°C, K
Density	kg/m ³
Frequency	Hz
Pressure	mbar, bar, mmWC
Relative humidity (RH)	%
Oil mist concentration	mg/l
Opacity	%
Acceleration (vibration)	g, m/s ²
Torque (M)	Nm

Table 2: Variables and units of measurement that are used

2 Safety instructions

2.1 Hazard levels in warnings

The warnings have different levels according to the severity of the hazard. The hazard levels with the corresponding signal words and warning symbols are described below.

	 DANGER
	<p>Immediate risk of death or serious injury.</p> <ul style="list-style-type: none"> ▶ Indicates a high-risk hazard which, if not avoided, will result in death or serious injury.
	 WARNING
	<p>Potential risk of death or serious injury.</p> <ul style="list-style-type: none"> ▶ Indicates a medium-risk hazard which, if not avoided, could result in death or serious injury.
	 CAUTION
	<p>Potential risk of minor injury.</p> <ul style="list-style-type: none"> ▶ Indicates a low-risk hazard that, if not avoided, may result in minor or moderate injury.
	NOTE
	<p>Potential damage to the device or the surroundings.</p> <ul style="list-style-type: none"> ▶ Indicates a potential hazard, with the aim of preventing damage.

2.2 Important information about retrofitting or converting engines

The installation and starting up of the device when retrofitting or converting engines **that are not new engines** may only be carried out by authorised Schaller service partners.

Trained, qualified personnel of the customer are also allowed to assemble, install and start up the device on new engines.

Operation and maintenance of the device may also be carried out by qualified personnel of the customer. However, the operator must ensure for this purpose that the personnel for the work/activities defined in these installation instructions have the appropriate qualifications and/or are trained and fully understand the contents of these installation instructions.

2.3 Information, warning and mandatory signs that are used

The following symbols and signs according to DIN EN ISO 7010 and DIN 4844-2 are used in these installation instructions:

























Symbol	Explanation
	General warning sign
	Warning; electricity
	Warning; explosive atmosphere (Atex; IECEx)
	Warning; hot surface
	Wear protective gloves
	Wear ear protection
	Wear eye protection
	Wear head protection
	Refer to installation instructions/instructions
	Check
	Technical product documentation, e.g.: <ul style="list-style-type: none"> • Parts lists • Installation kit drawings • Installation drawings

Table 3: Information, warning and mandatory signs

2.4 General safety instructions

	<div style="background-color: #FFD700; padding: 5px;">⚠ CAUTION</div> <p>Safe and proper use of the device</p> <ul style="list-style-type: none"> ▶ Read the installation instructions and other documents that accompany the product carefully and keep them in a suitable place for future reference. ▶ For repair and service work, you must follow the installation instructions.
 	<div style="background-color: #005696; color: white; padding: 5px;">NOTE</div> <p>Personal protective equipment</p> <p>Operating the device or working on the device <u>without</u> protective equipment may result in serious injury. For the workplace PPE, the following protective equipment must be used:</p> <ul style="list-style-type: none"> ▶ DIN EN 388:2016 Protective gloves against mechanical risks, 2341X, and DIN EN 407:2020-06, Protective gloves against thermal risks, X1XXXX ▶ Safety glasses in accordance with DIN EN 166 or DIN EN 170 ▶ Safety helmet in accordance with DIN EN 397 and DIN EN 50365 ▶ ESD safety shoes according to ESD standard DIN EN 61340-5-1
	<div style="background-color: #8B0000; color: white; padding: 5px;">⚠ DANGER</div> <p>Malfunction</p> <p>Operating the device with a malfunction creates a risk of death and may cause environmental damage and/or damage to the device.</p> <ul style="list-style-type: none"> ▶ The device must be taken out of operation immediately in the event of a malfunction.
  	<div style="background-color: #8B0000; color: white; padding: 5px;">⚠ DANGER</div> <p>Mechanical hazards</p> <p>There is a risk of serious injury, including death, from explosion in the crankcase as a result of incorrect assembly or installation.</p> <ul style="list-style-type: none"> ▶ Only trained specialist personnel are allowed to carry out assembly, installation and starting up of the oil mist detection system. The qualified personnel must have knowledge of the type of protection, instructions and regulations for the equipment in potentially explosive atmospheres. Check whether the classification (see name plate) is applicable for this application. ▶ The device must be installed in accordance with IACS Unified Requirement UR M10.
	<div style="background-color: #8B0000; color: white; padding: 5px;">⚠ DANGER</div> <p>Pneumatic hazards</p> <p>Assembly, installation and disassembly of the device must only be carried out when the device is not under pressure.</p> <ul style="list-style-type: none"> ▶ Before starting work, deactivate the compressed air supply to the VISATRON[®] VN301^{plus} central unit.

⚠ DANGER

Electrical hazards

Electrical damage to the device from welding work on the engine as a result of overvoltage.

- ▶ Before starting work, disconnect the VISATRON® VN301^{plus} central unit from the power supply.





Electrical damage to the device on when installing and removing the engine.

- ▶ Before starting work, disconnect the VISATRON® VN301^{plus} central unit from the power supply.

Electrical damage during repair work on the device

- ▶ Before starting work, disconnect the VISATRON® VN301^{plus} central unit from the power supply and/or ensure that the housing is earthed.

⚠ DANGER









Risk of burns

Depending on the media that are used, the installation location and the operating mode, the surfaces of the device and the connected parts of the system may become hot. The heat can cause serious injury.

- ▶ Insulate the device against heat radiation on installation, depending on the wall temperature.
- ▶ Make sure that the surfaces have cooled down sufficiently.
- ▶ Install guards that prevent contact with the device.
- ▶ Observe the allowed ambient temperature T_a (during intended use): $+5\text{ °C} \leq T_a \leq +70\text{ °C}$.
- ▶ Typical gases of ignition protection category T4: T4 maximum surface temperature must be $\leq 135\text{ °C}$.
- ▶ Wear suitable protective gloves.

⚠ DANGER

Noise pollution

From experience, at the mounting position of the device, there are high noise emissions from running of the engine, which can damage hearing and cause environmental noise pollution.

- ▶ Take measures to protect against noise when installing the device.
- ▶ Wear suitable ear protection during operation.
- ▶ Observe the statutory regulations for protection against noise.

**NOTE****Maintenance and repair work**

It is only safe to operate the device when it is in perfect working condition. The operator is responsible for proper and safe condition of the device, which means:

- ▶ Have the specified inspections and maintenance work carried out regularly.
- ▶ Carry out the specified checks before operation.

2.4.1 Safety instructions for potentially explosive atmospheres**DANGER****Hazards in potentially explosive atmospheres**

The following basic safety instructions apply to SCHALLER products intended for use in potentially explosive atmospheres:

- ▶ The installation and starting up of the device in potentially explosive atmospheres may only be carried out by authorised Schaller service partners.
- ▶ Only the customer's personnel trained for potentially explosive atmospheres may operate and maintain the product.
- ▶ Make sure that the product is approved for the application.
- ▶ Always comply with the zoning to install the product in the correct location.
- ▶ Only use tools suitable for potentially explosive atmospheres.
- ▶ Note that modifications are not allowed without prior approval from SCHALLER AUTOMATION.
- ▶ Make sure that damaged products are not installed or operated in the potentially explosive atmosphere.
- ▶ Modifications to the device or the electrical connections mean that it is no longer safe to operate and there is no longer protection against explosion.
- ▶ Observe the characteristics and rated operating conditions on the type and data plates.
- ▶ Observe the national and local safety regulations, accident prevention regulations and assembly and installation regulations.
- ▶ Observe the general safety instructions and rules of technology.
- ▶ Observe any additional information signs on the device.

3 Assembly and installation

WARNING

Risk of injury from design changes

Unauthorised modification or removal of functional parts puts the function of important safety components at risk and can lead to serious damage to property or the environment and to serious injuries or even death.

- ▶ Familiarise yourself with the safety instructions to be followed before starting installation.
 - ⇒ Section 2.2 Important information about retrofitting or converting engines
 - ⇒ Section 2.4 General safety instructions
- ▶ Statutory regulations must be observed and complied with.
- ▶ Only use approved and suitable components and spare parts.

3.1 Hybrid cable

NOTE

Functional failure of the hybrid cable as the result of incorrect routing and installation

For proper functioning of the oil mist detection system, the hybrid cable must be laid **and** installed in accordance with the manufacturer's specifications.

The following applies in all cases:

- ▶ For (integrated) hose lines, length changes of -4 % to +2 % can occur under maximum operating pressure relative to the nominal length. Therefore, they should be installed with some slack. (see Section 3.1.1, Figure 1)
- ▶ Do not install the hybrid cable twisted
- ▶ Do not pinch the hybrid cable in the cable clamp (see Section 3.1.2)
- ▶ Observe the minimum bending radius (see Section 3.1.1, Figure 2)
- ▶ Protect hybrid cables against external damage

3.1.1 Installing cable

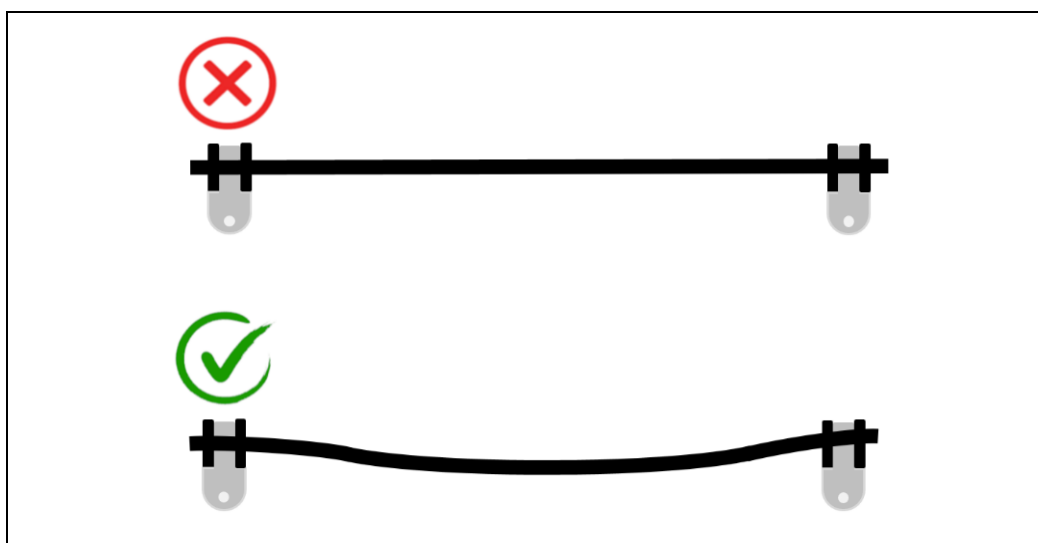

Fig.: 1 : Installing hybrid cable

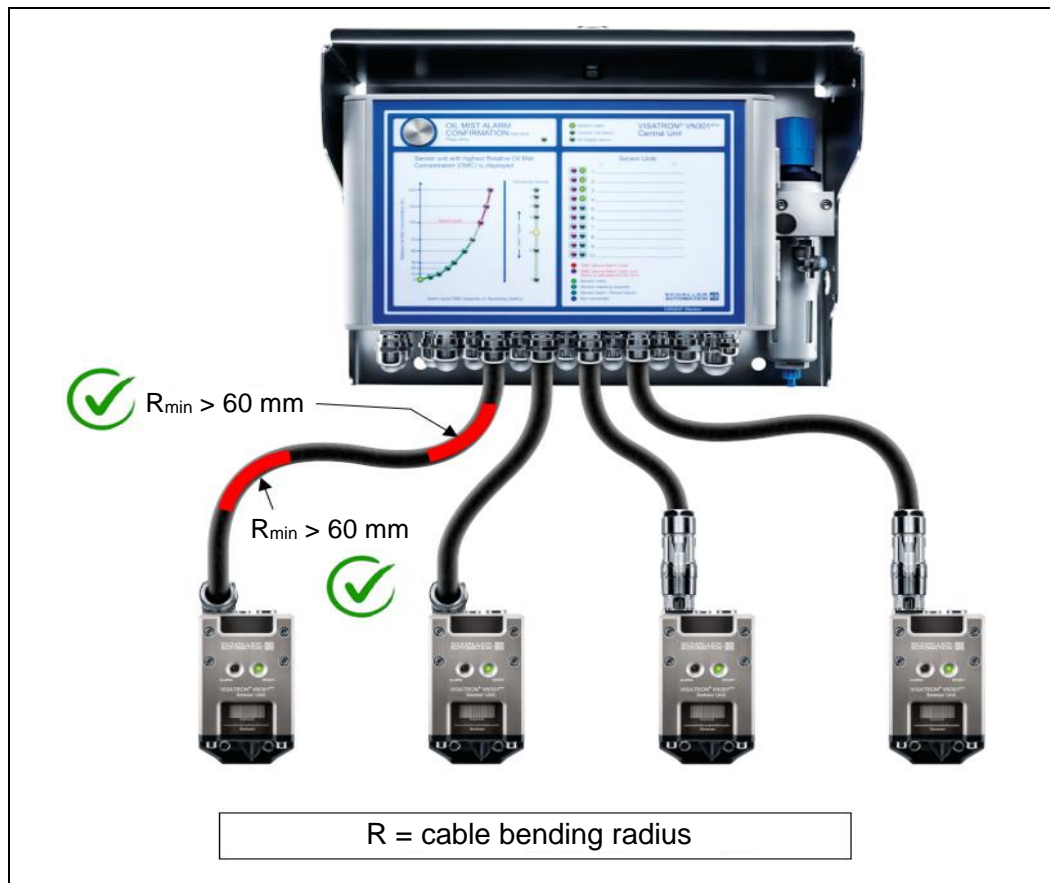
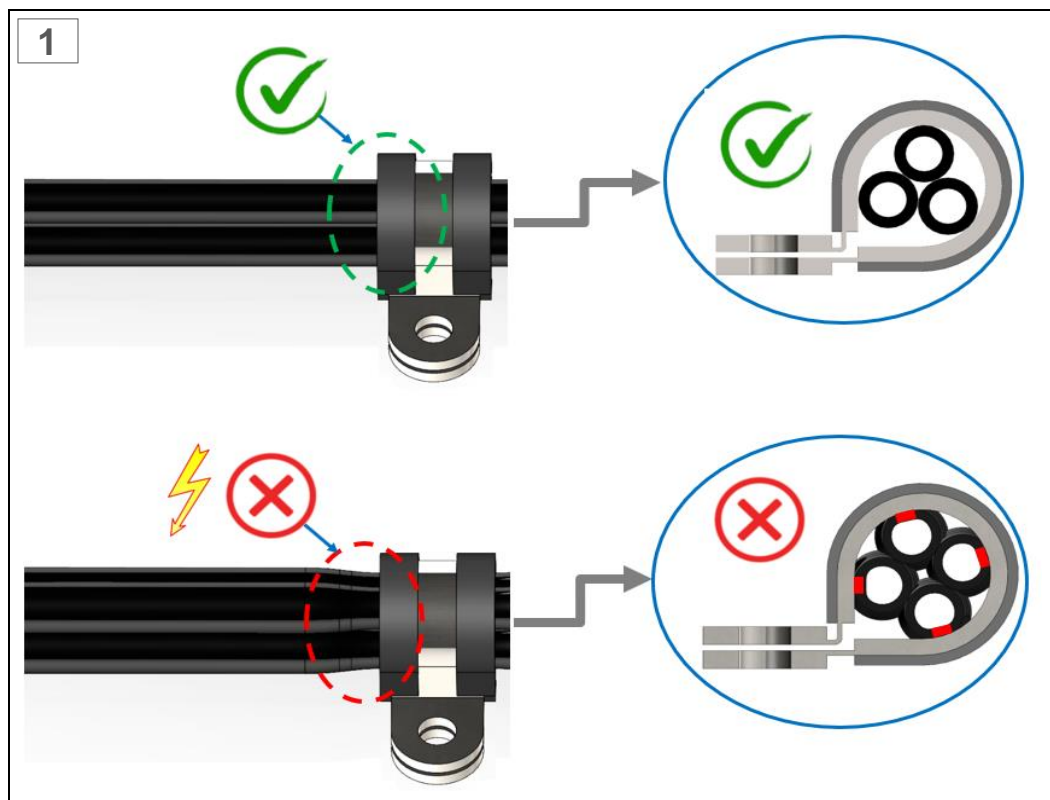

Fig.: 2 : Permissible bending radius of hybrid cable

3.1.2 Assembly



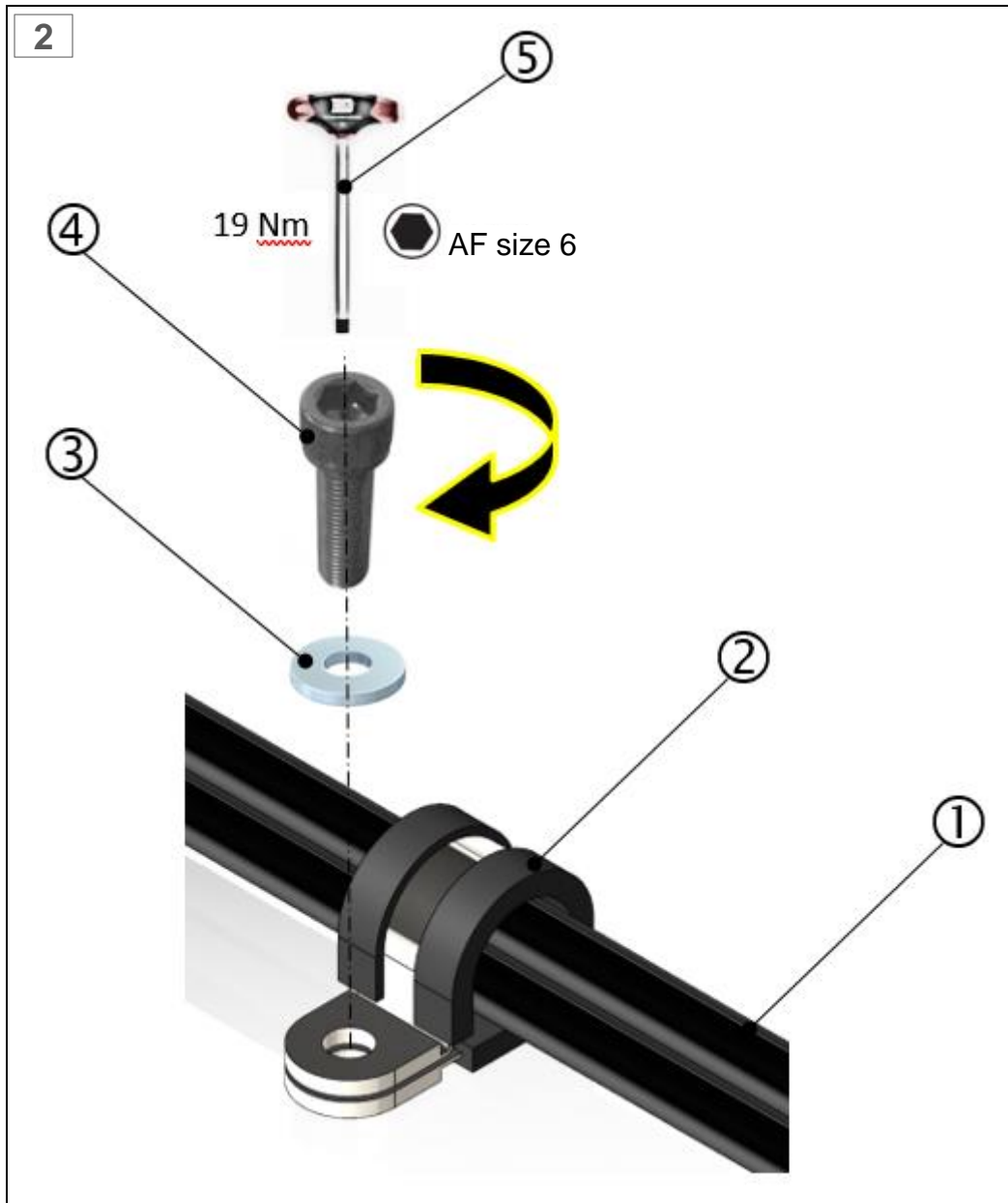

Fig.: 3 : Installing the cable clamp for hybrid cable (steps 1-2)

- | | |
|---|---|
| 1: Hybrid cable VN301 ^{plus} | 4: Cheese head screw ISO 4762 - M8 x 25 - 8.8 |
| 2: DIN 3016-1 clamp - D1-12x20-W1-2-CR | 5: Allen key, size 6 |
| 3: Lock washer S - 8 - spring steel zinc-plated | |

NOTE

Installing hybrid cable

- ▶ Repeat installation steps 1 to 2 for all hybrid cables that are to be installed.
- ▶ The customer specifies the installation positions of the clamps.
- ▶ Observe the installation kit drawing supplied with the device



3.1.3 Installing the hybrid cable on the VN301^{plus} central unit



⚠ DANGER

Electrical hazards
Installation and repair work are only allowed when the device is de-energised.

- ▶ Before starting work, disconnect the VISATRON[®] VN301^{plus} / VN301^{plus} EX central unit from the power supply.

You may only assemble, install and remove the device when the engine is switched off.

- ▶ Before starting work, switch off the engine.

a) Overview of the sensor cable assignment on the VN301^{plus} central unit

Up to 10 sensor units (all connections used) can be connected to the central unit, and up to 20 sensor units as master-slave version (all connections used).

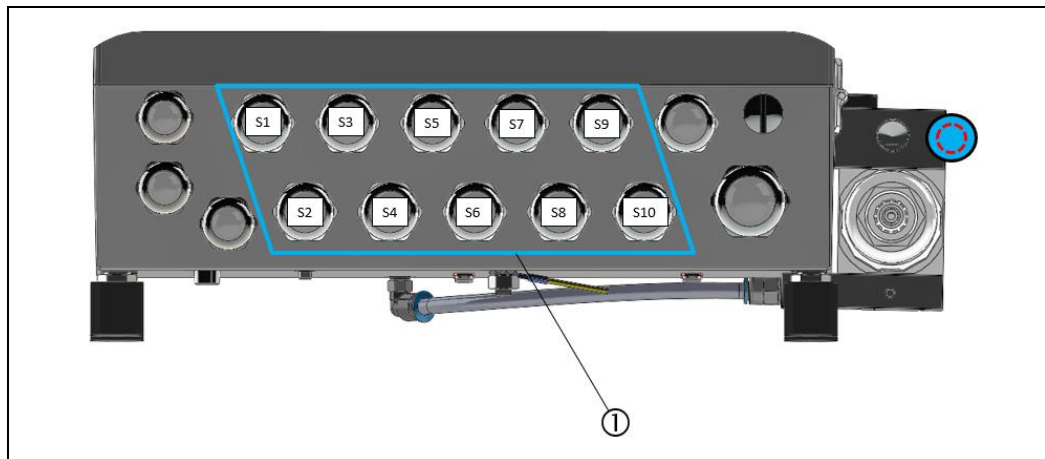

Fig.: 4 : Central unit VN301plus (all connections used), view of cable connection panel

1: Connections that are being used (sensor units 1-10)

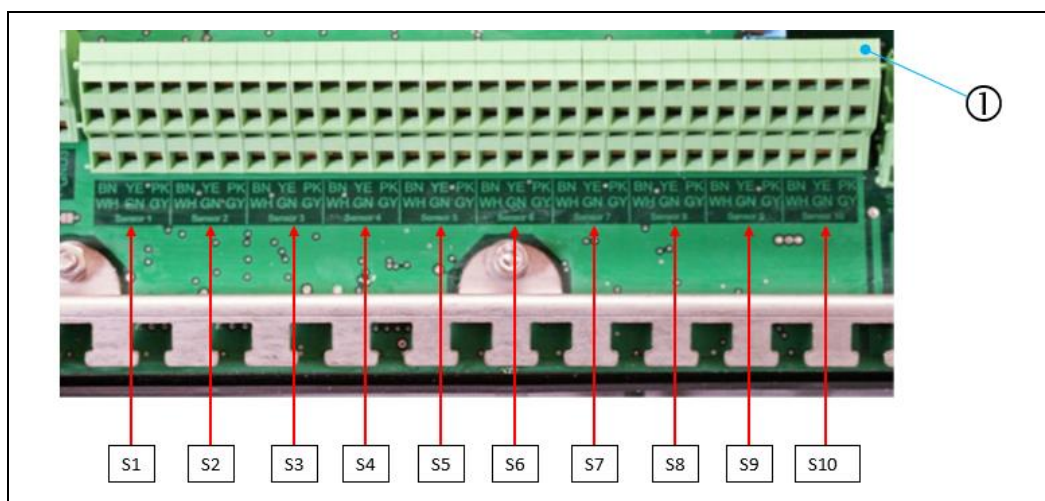

Fig.: 5 : VN301^{plus} central unit (all connections used), view of terminal block sensor connection

1: Connections that are being used on the terminal block (sensor units 1-10)

As an alternative to using all the connections with connected sensor units, the central unit can also be operated with some connections not used (up to 9 sensor units). In the following example, a total of 5 sensor units are connected to connections S1-S5 [①]. The remaining connections that are not used [②] are fitted with M20x1.5 blanking plugs at the factory. Please note here that the number of sensor units used must be indicated when ordering.

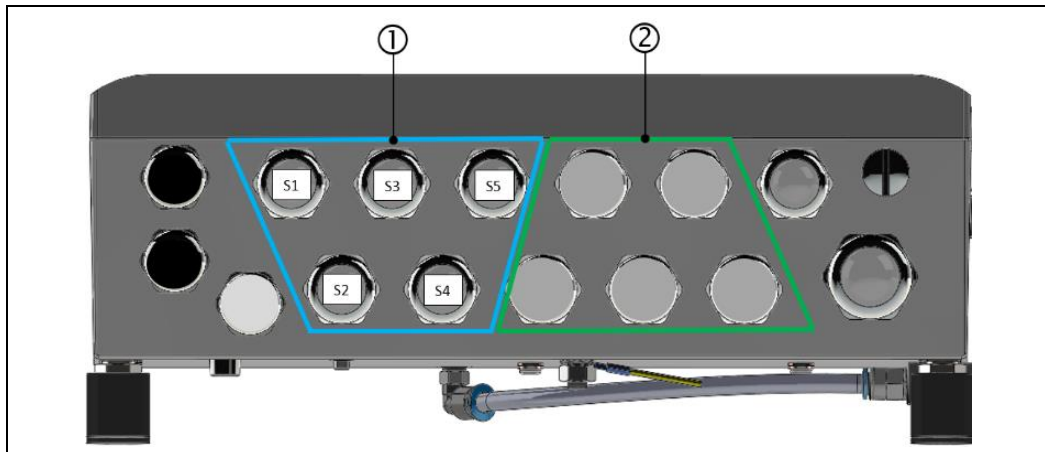

Fig.: 6 : Central unit VN301plus (not all connections used), view of cable connection panel

1: Connections that are being used (sensor units 1-5)

2: Connections that are not being used (M20x1.5 blanking plugs)

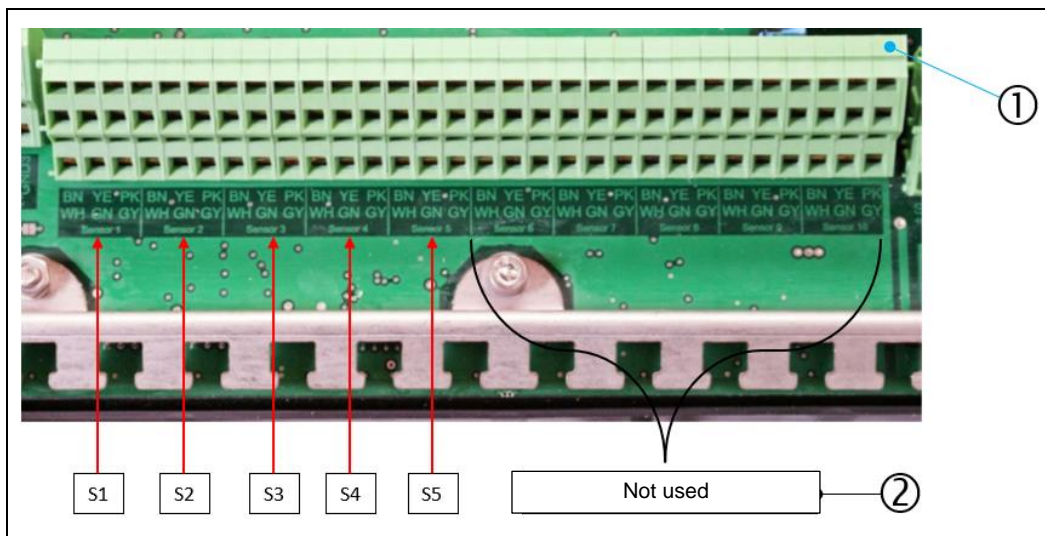
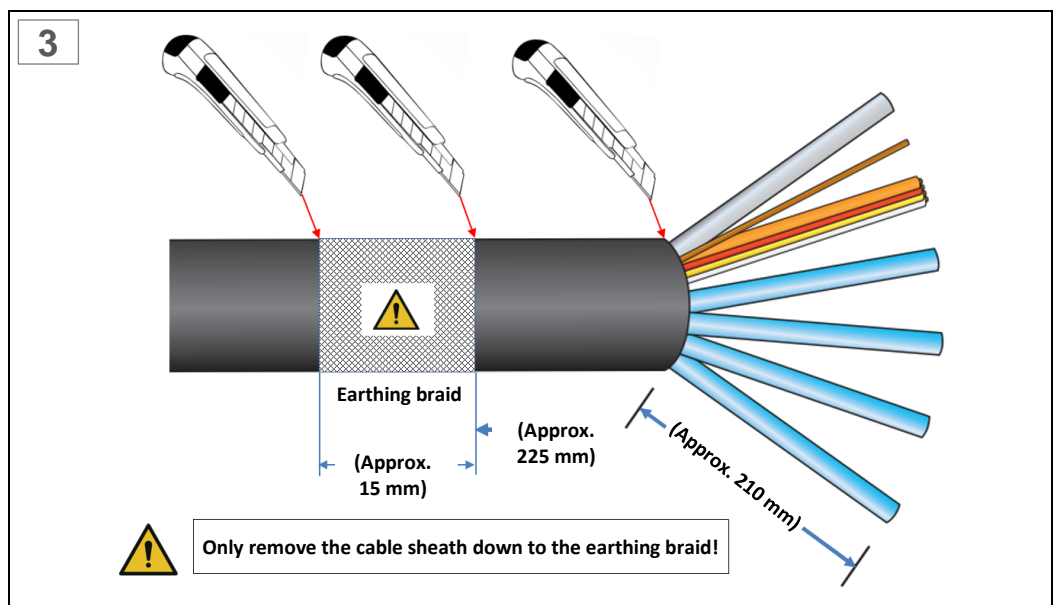
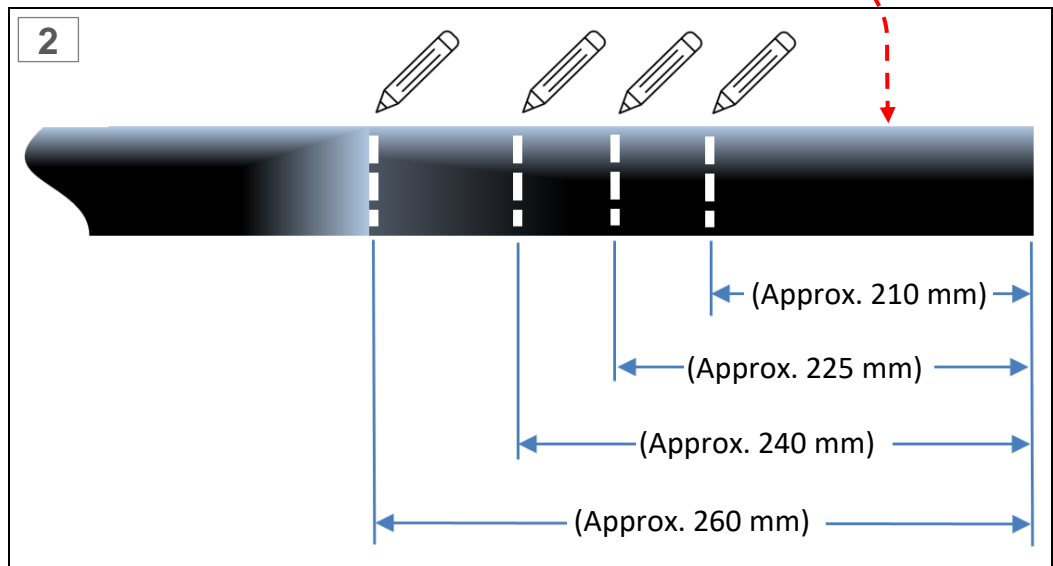
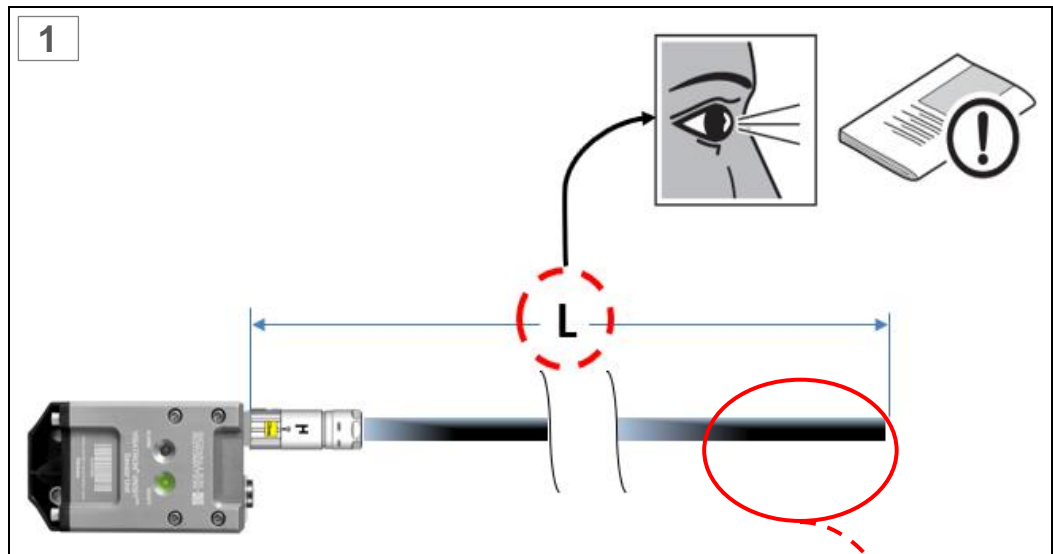

Fig.: 7 : VN301^{plus} central unit (not all connections used), view of terminal block sensor connection

1: Connections that are being used on the terminal block (sensor units 1-5)

2: Connections that are not being used on the terminal block (sensor units 6-10)

b) Preparing the hybrid cable (standard assembly) and installing in the VN301^{plus} central unit



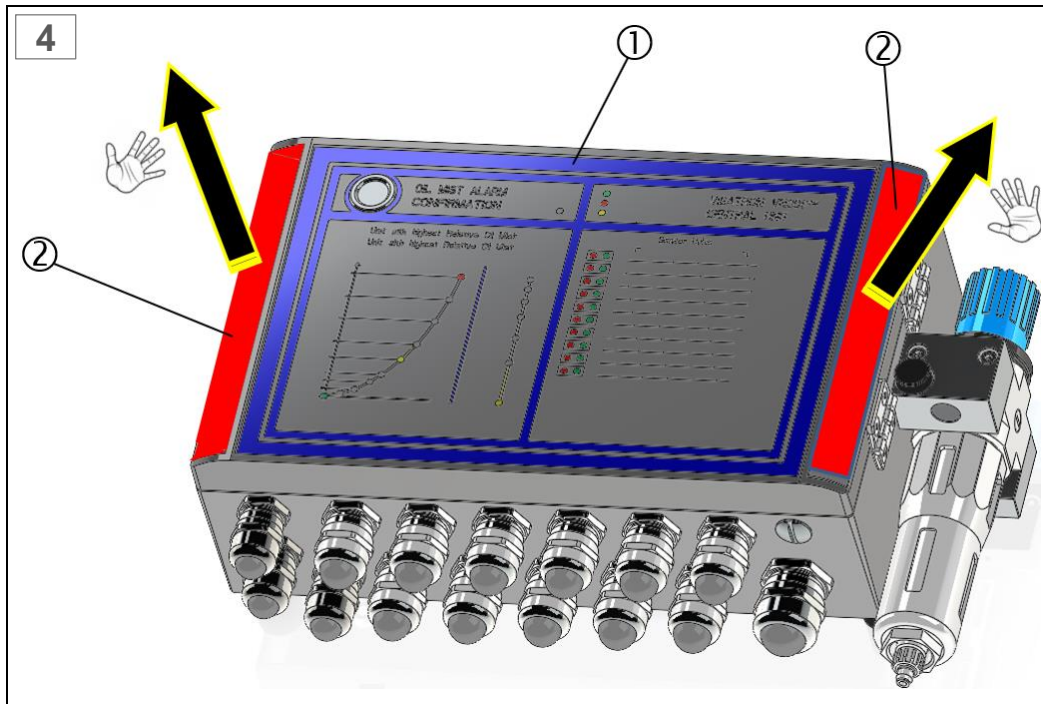

- 1: VN301^{plus} central unit
- 2: Aluminium cover strip

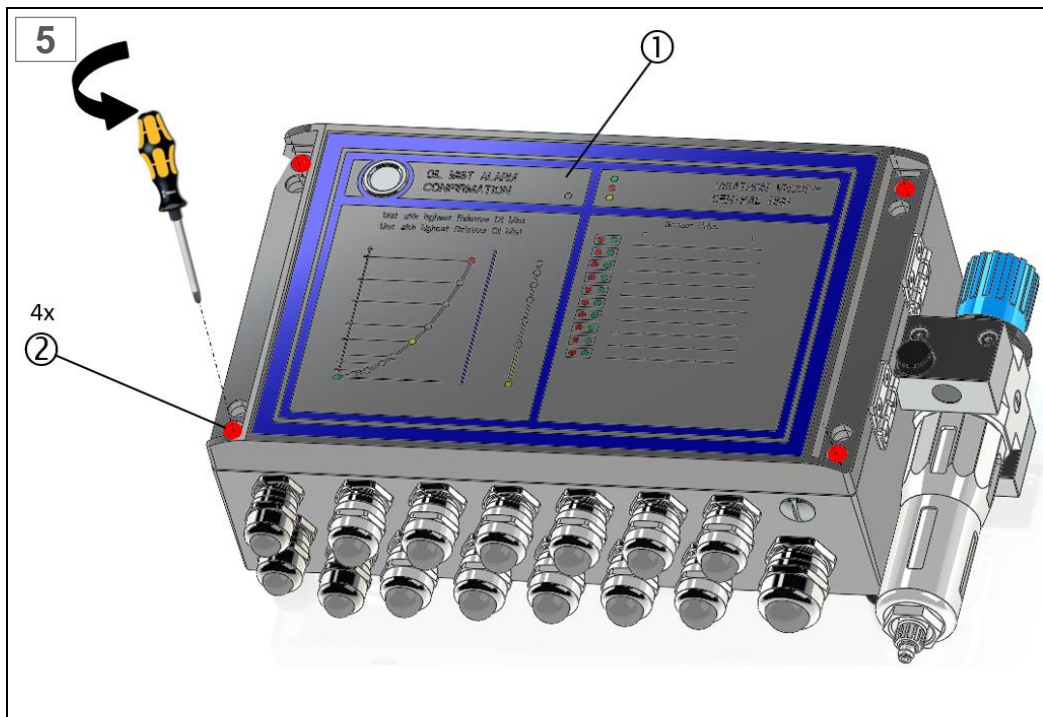

- 1: Cover, VN301^{plus} central unit
- 2: 4 pcs. fixing screws (captive screws)

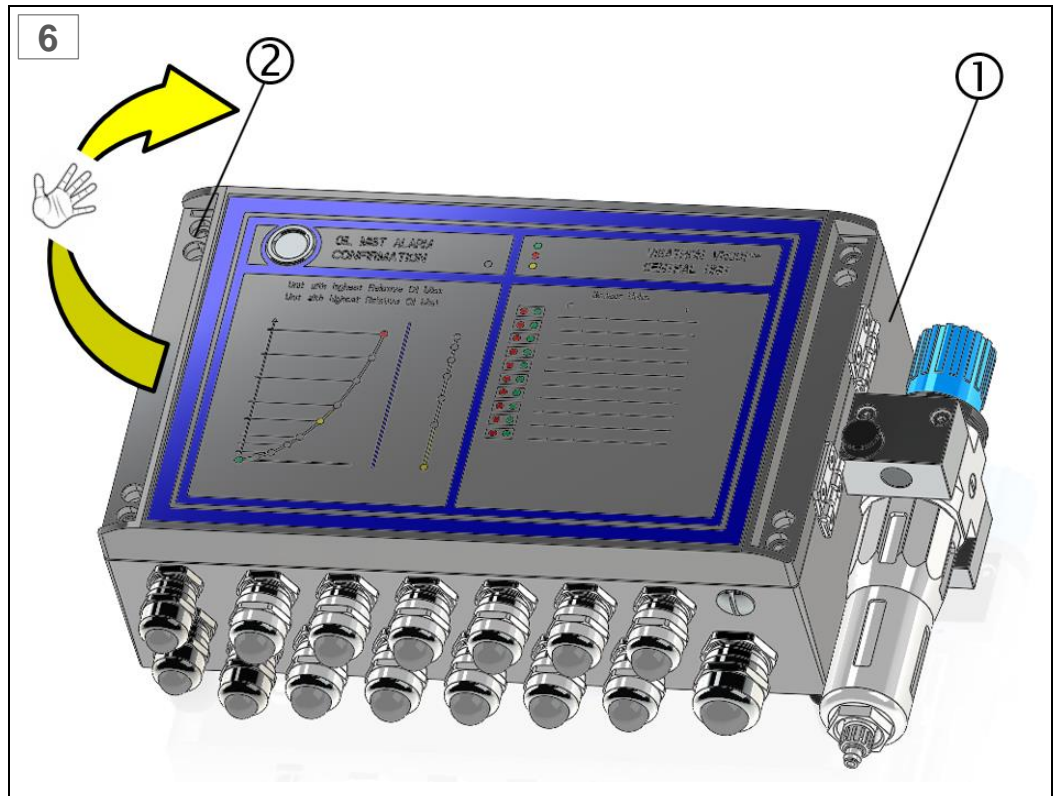

- 1: Bottom half of housing, VN301^{plus} central unit
- 2: Cover, VN301^{plus} central unit

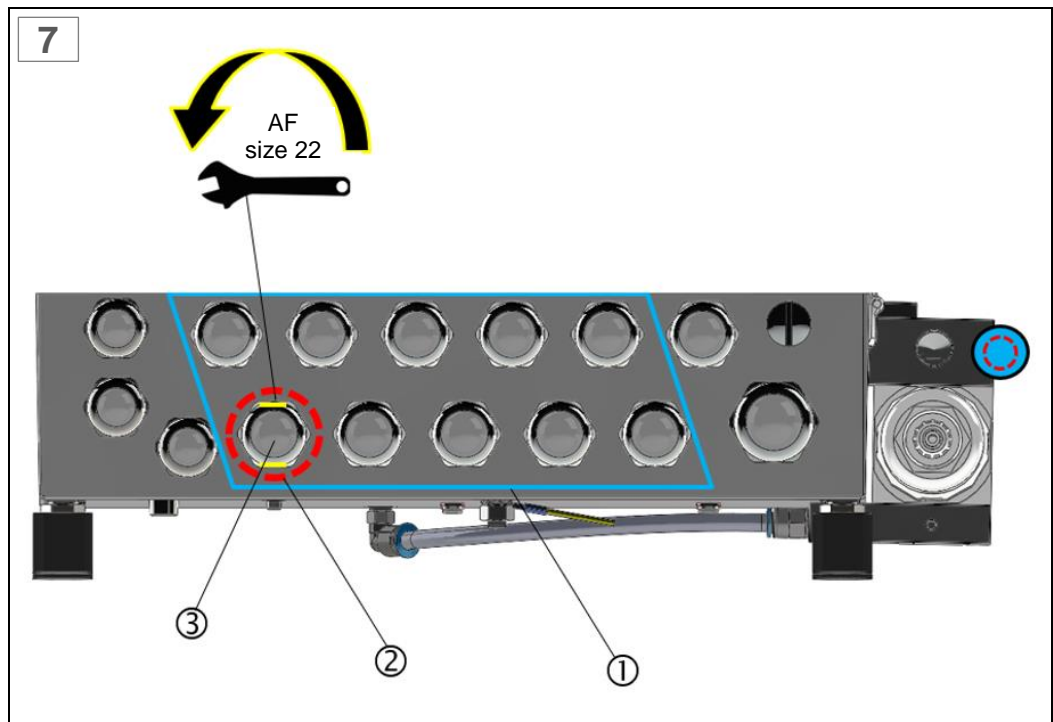

- 1: VN301^{plus} central unit, view of cable connection panel
- 2: "Hybrid cable" cable gland (example)
- 3: Cable gland screw plug (remove if necessary)

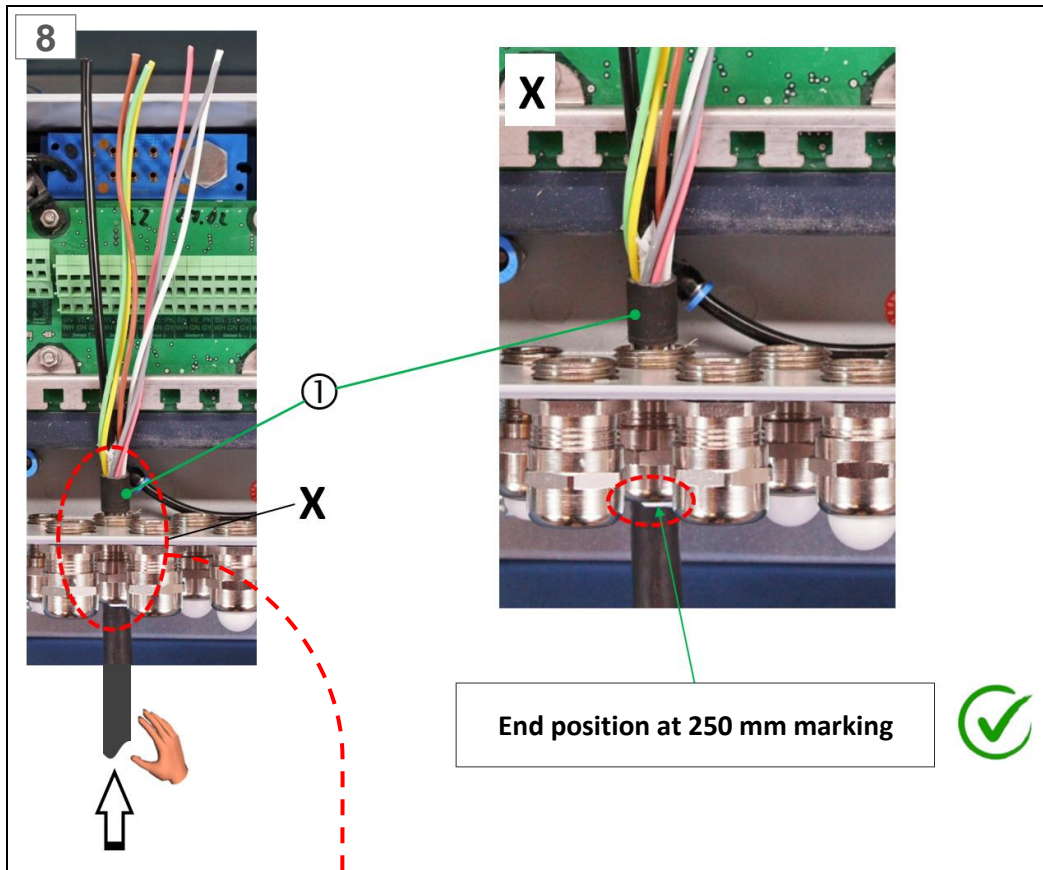

1: Hybrid cable

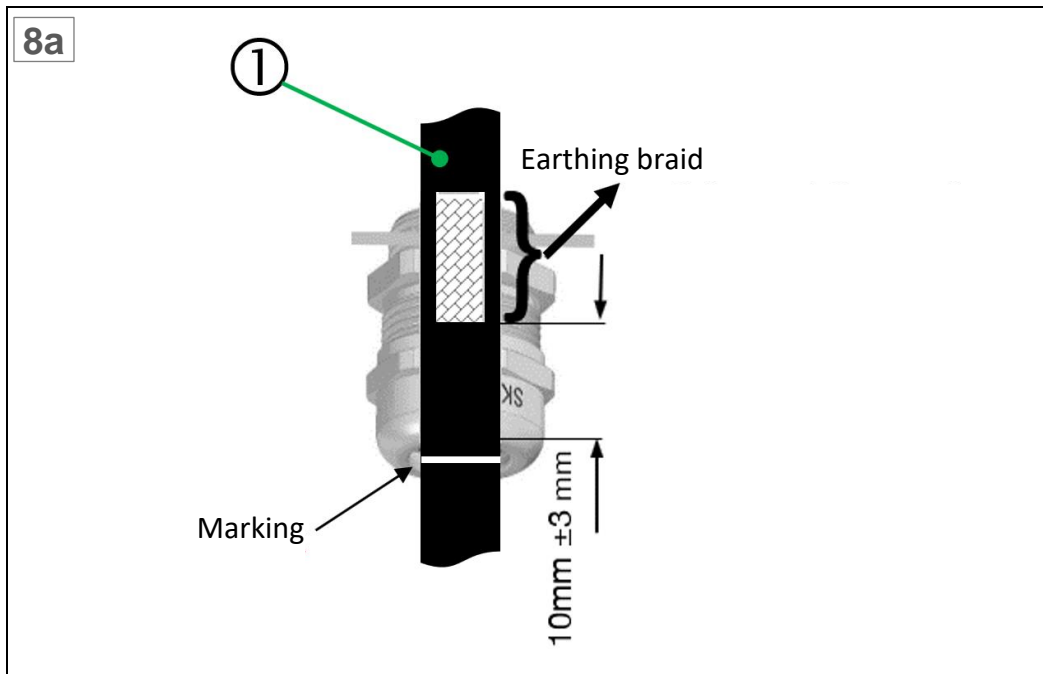

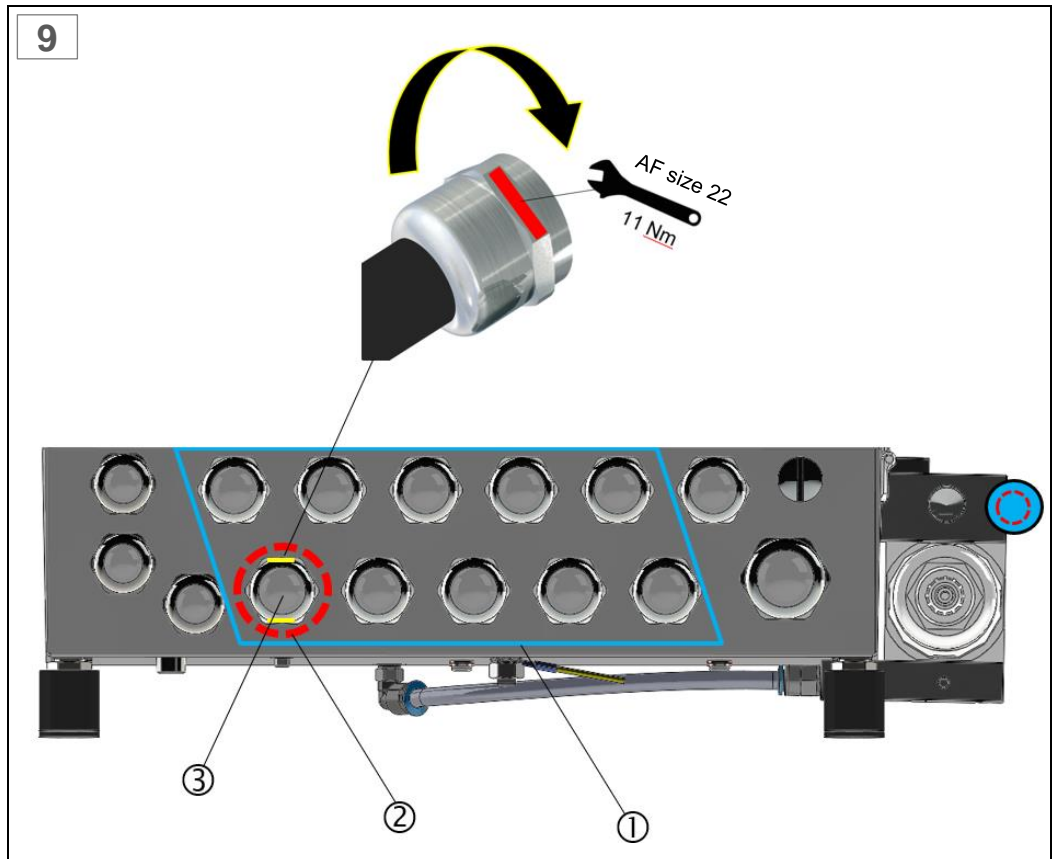

1: VN301^{plus} central unit, view of cable connection panel
 2: "Hybrid cable" cable gland (example)
 3: Cable gland screw plug (remove if necessary)

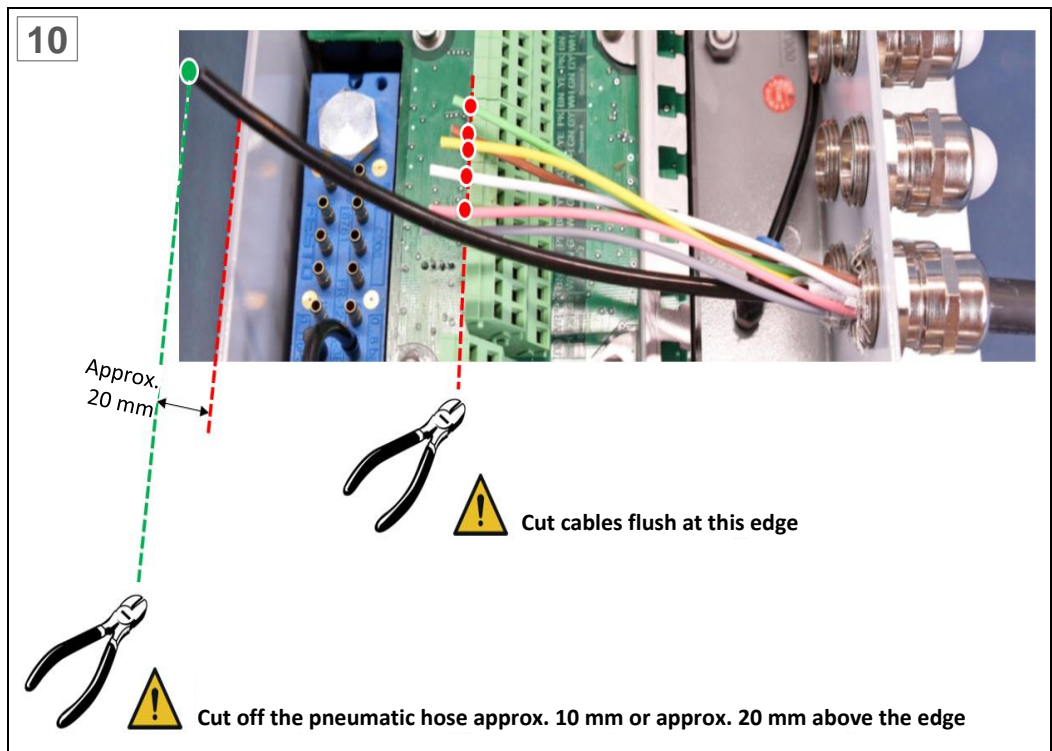

Prepare single wires with standard assembly:

VN301 ^{plus} hybrid cable (wire cross-sections)	
Wire <ul style="list-style-type: none"> • White • Brown 	<u>Applicable wire cross-section:</u> Ø 0.75 mm ²
Wire <ul style="list-style-type: none"> • Green • Yellow • Grey • Pink 	<u>Applicable wire cross-section:</u> Ø 0.50 mm ²

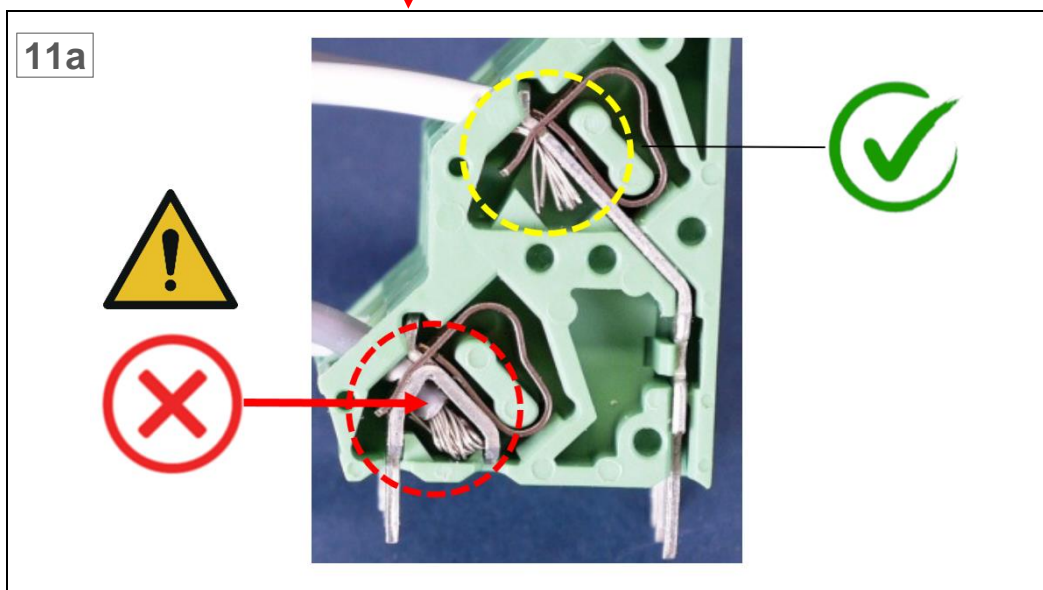
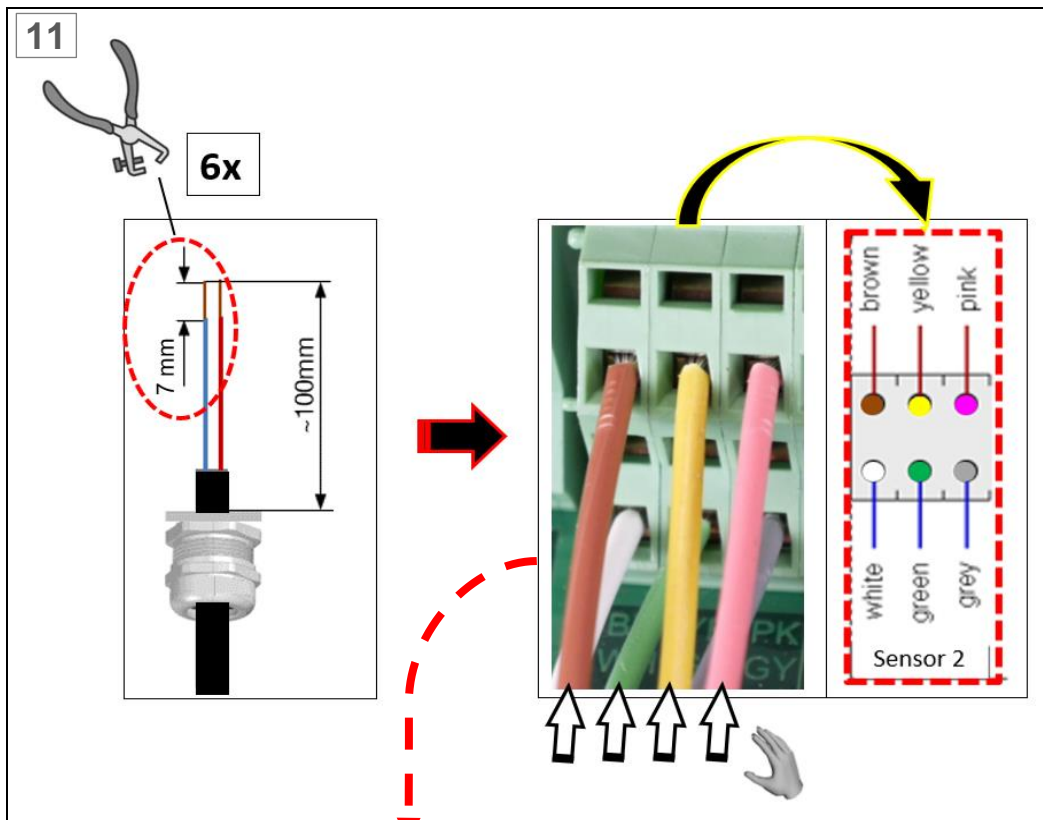

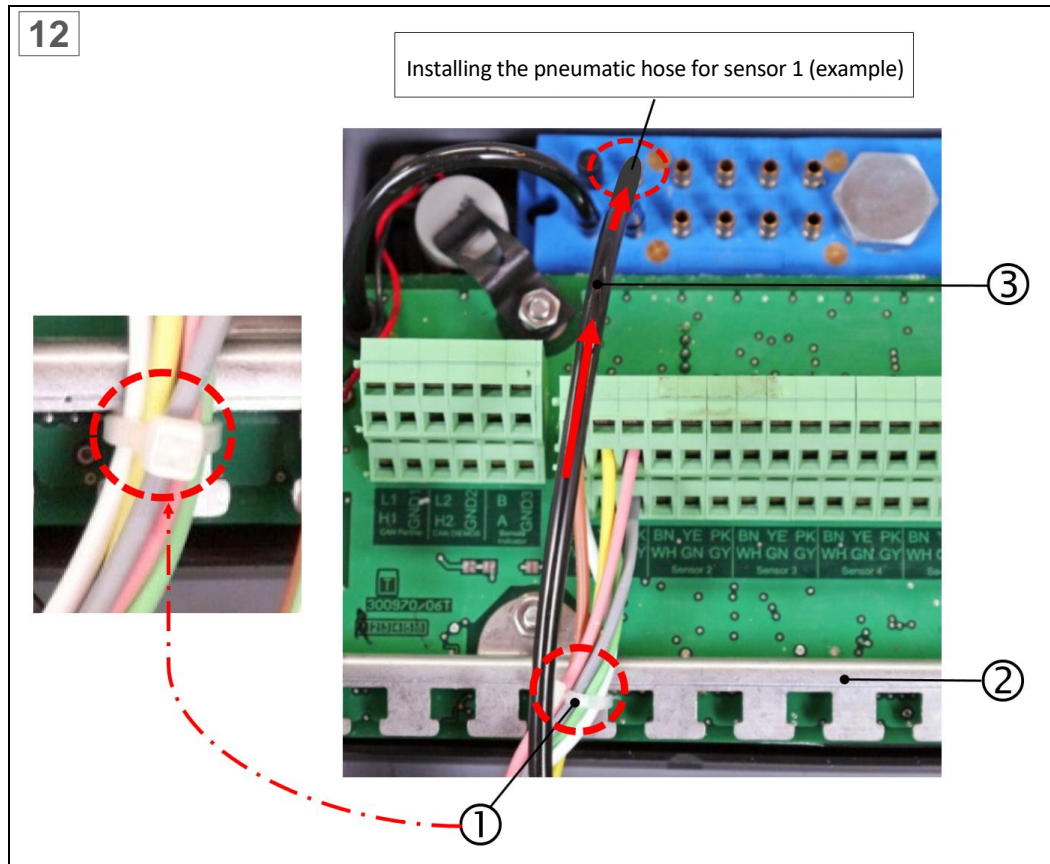

Fig.: 8 : Assembly and installation of hybrid cable, VN301^{plus} central unit (steps 1 - 12)

1: Secure the single wires with cable ties on the cable tie retaining plate (**do not secure the compressed air hose**)

2: Cable tie retaining plate

3: Pneumatic hose

NOTE



Functional failure of the hybrid cable as the result of incorrect installation

For proper functioning of the oil mist detection system, the hybrid cable must be installed in accordance with the manufacturer's specifications.

The following applies in all cases:

- ▶ The pneumatic hose [③] must not be fixed to the cable tie retaining plate or similar using cable ties. (Fig. 9)
- ▶ The pneumatic hoses must be installed correctly and in accordance with the manufacturer's instructions as shown in Fig. 8!



DANGER



Malfunction

Operating the device with a malfunction creates a risk of death and may cause environmental damage and/or damage to the device.

- ▶ The device must be taken out of operation immediately in the event of a malfunction.

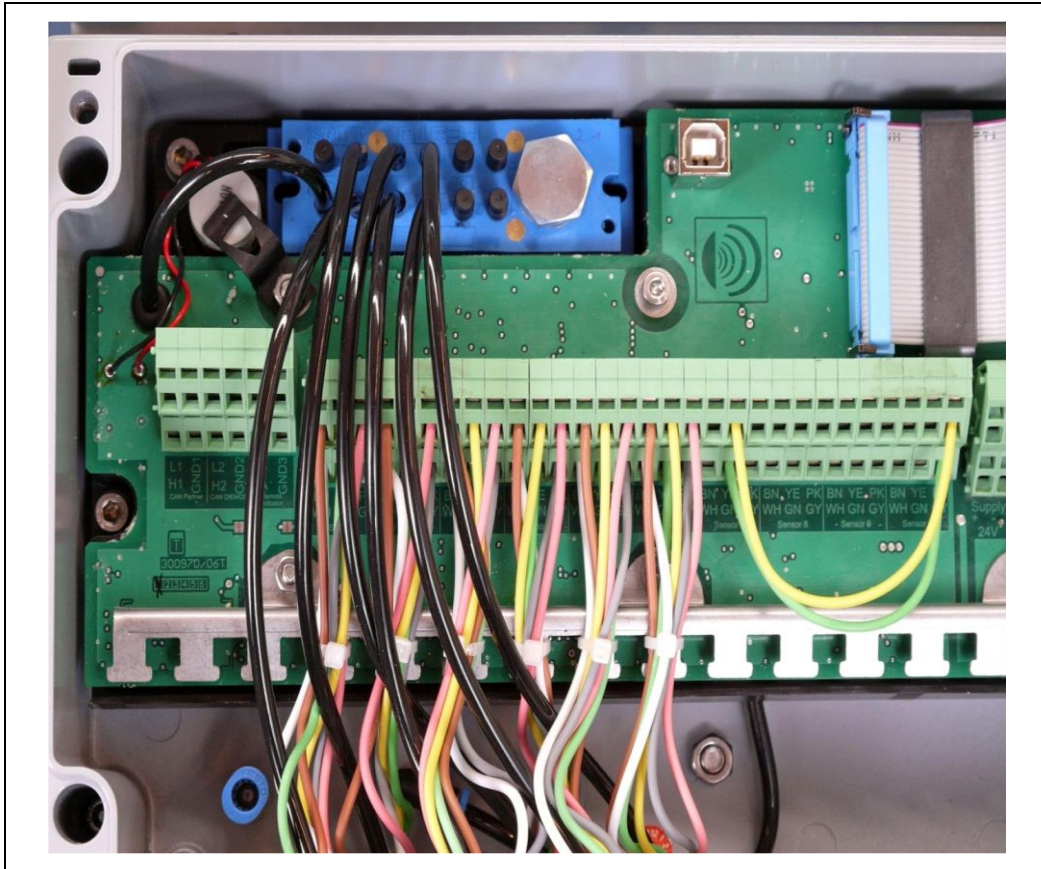

Fig.: 9 : Assembly and installation complete (example with 6 hybrid hoses)

c) Alternative assembly of the single wires by crimping with ferrules

As an alternative to the standard assembly of single wires, as already described in detail in Section 3.1.3 b) above, the single wires of the hybrid cable can also be assembled using the standard crimping method.

⇒ Section 3.1.3 b) Preparing the hybrid cable (standard assembly) and installing in the VN301plus central unit

NOTE

Assembly of single wires with the crimping process

- ▶ The crimping process and the crimped connection are applied correctly in accordance with **DIN EN60352-2**. It defines basic requirements, describes the test method and provides important application instructions and recommendations.
- ▶ To produce a standard-compliant and permanently reliable crimped connection in accordance with **DIN EN60352-2**, the conductor, contact and tool must be optimally matched to each other. Each crimp must also be well prepared and created correctly with the appropriate tool.
- ▶ Crimping tools according to **DIN 41641-1** are recommended.

For a permanent and reliable crimped connection, the following steps must always be performed in chronological order:

Step 1: Select the crimping die:

- ▶ As per the figure below, a distinction is made between trapezoidal (2), square (3), hexagonal (1) and Weidmüller (4) crimping dies:

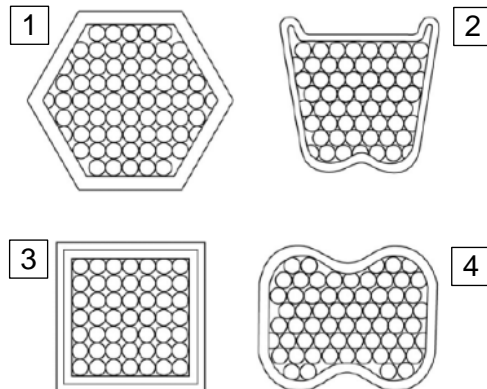

Step 2: Select the ferrule and tools:

- ▶ Ferrules should always meet the requirements of **DIN 46228**.
- ▶ Crimping tools according to **DIN 41641-1** are recommended, for crimped connections free of defects. At least 50,000 crimping cycles can be performed with the standardised tools without any loss of quality. However, regular maintenance and inspections are strongly recommended.

Step 3: Assembling the single wires:

- ▶ Start by cutting the single wire to the desired length.
Use suitable cutting tools in accordance with **DIN 41641-1**, which prevent the conductor from being sheared off, crushed or pulled out.
- ▶ Strip the conductor (as shown in the figure below).
When doing so, make sure you strip a length that suitable for the ferrule that you are using. (see **DIN EN60352-2**)

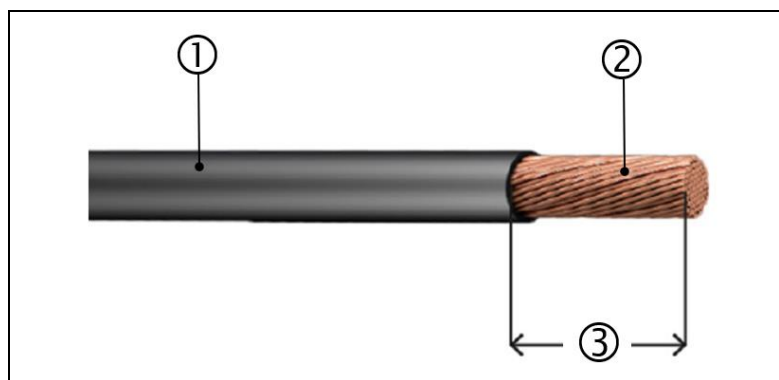

1: Single wire insulation
3: Stripped length

2: Conductor

Use suitable stripping tools in accordance with **DIN 41641-1** to ensure your work is free of defects.

- ▶ Inserting the conductor

To crimp the stripped cable end to the ferrule, the ferrule has to be pushed onto the conductor as far as it will go as shown in the figure below. The tube of the ferrule must be filled completely by the conductor. Note that the ferrules are only designed for finely stranded conductors in accordance with VDE 0295 Class 5. Normally, the conductors should protrude just under 1 mm out of the ferrule – for conductor cross-sections of more than 6 mm, they may protrude just under 2 mm.

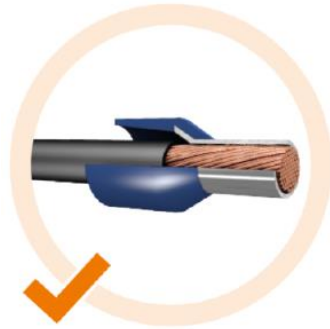

- ▶ Crimping

Once the conductor is optimally positioned in the ferrule as in the above figure, you can crimp the conductor.

Use suitable crimping tools in accordance with **DIN 41641-1** to ensure the connection is free of defects.

Step 4: Quality assurance

- ▶ **DIN EN 60352-2** recommends using tools and crimp contacts from the same manufacturer to ensure consistently high quality of work.

Prepare single wires on the hybrid cable with the crimping method:

The application of the crimping method is explained in detail below for all single wires of the hybrid cable. To prepare each of the single wires correctly, steps 1-10 have to be completed first, as per Section 3.1.3 b).

⇒ Section 3.1.3 b) Preparing the hybrid cable (standard assembly) and installing in the VN301plus central unit

For the alternative crimping method, instead of section 3.3.1 b), steps 11 to 11c (inclusive) and step 12 are defined as new steps, as described below:

VN301 ^{plus} hybrid cable (wire cross-sections)	
Wire <ul style="list-style-type: none"> • White • Brown 	<u>Applicable wire cross-section:</u> Ø 0.75 mm ²
Wire <ul style="list-style-type: none"> • Green • Yellow • Grey • Pink 	<u>Applicable wire cross-section:</u> Ø 0.50 mm ²

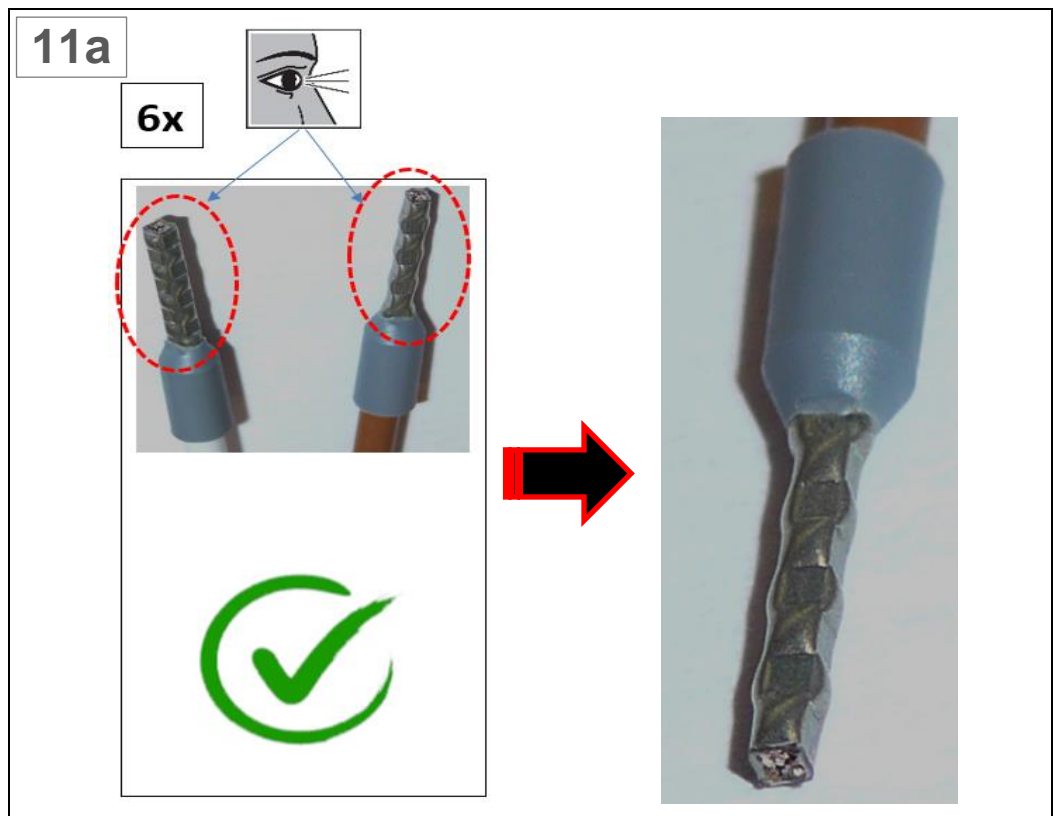
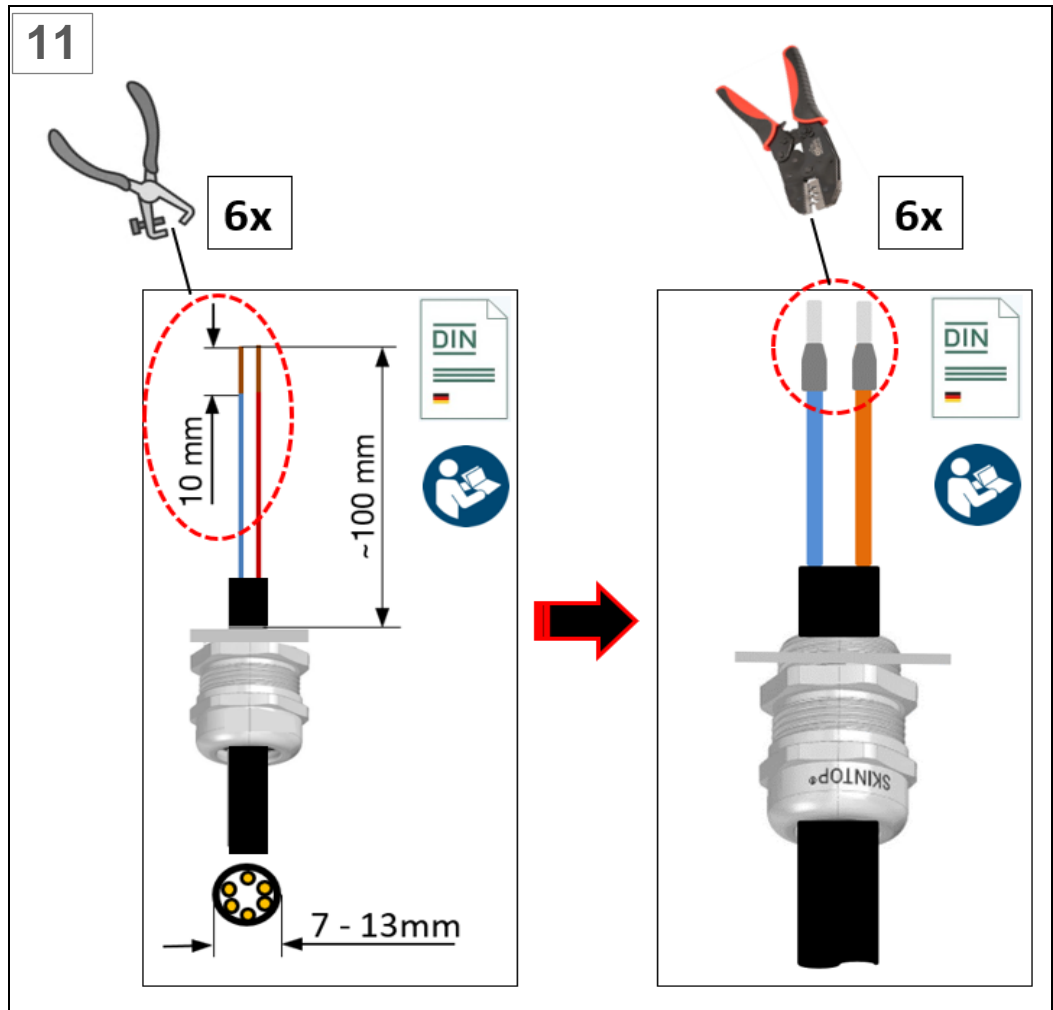

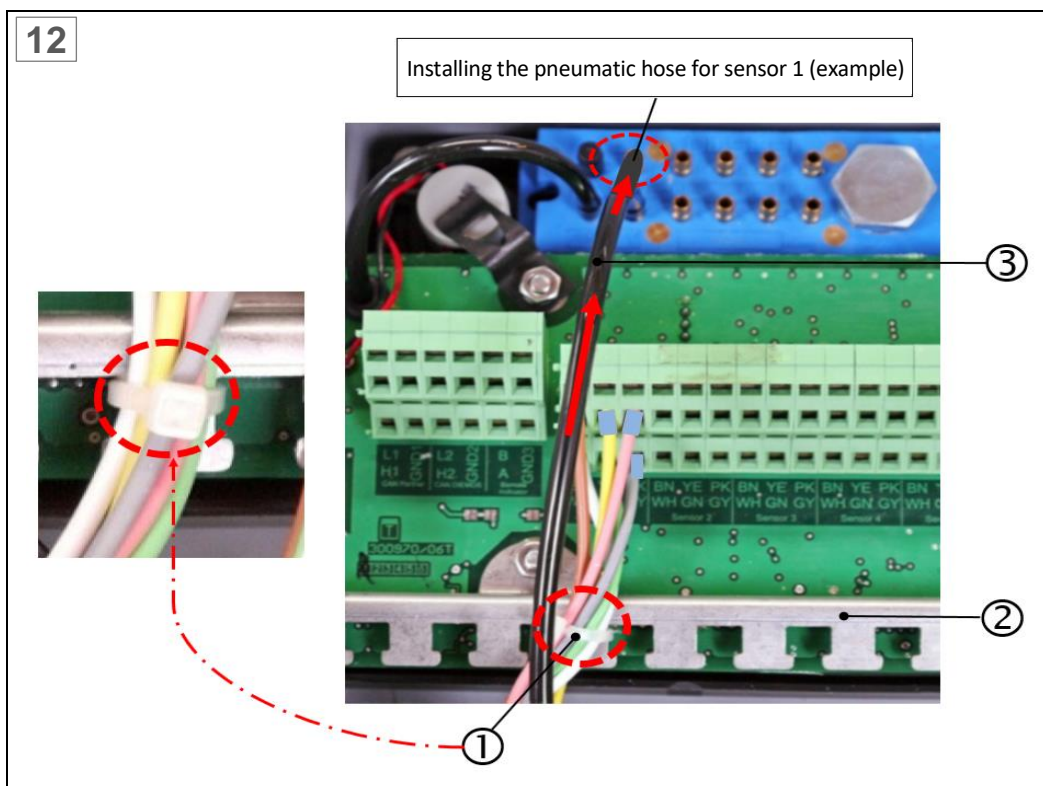
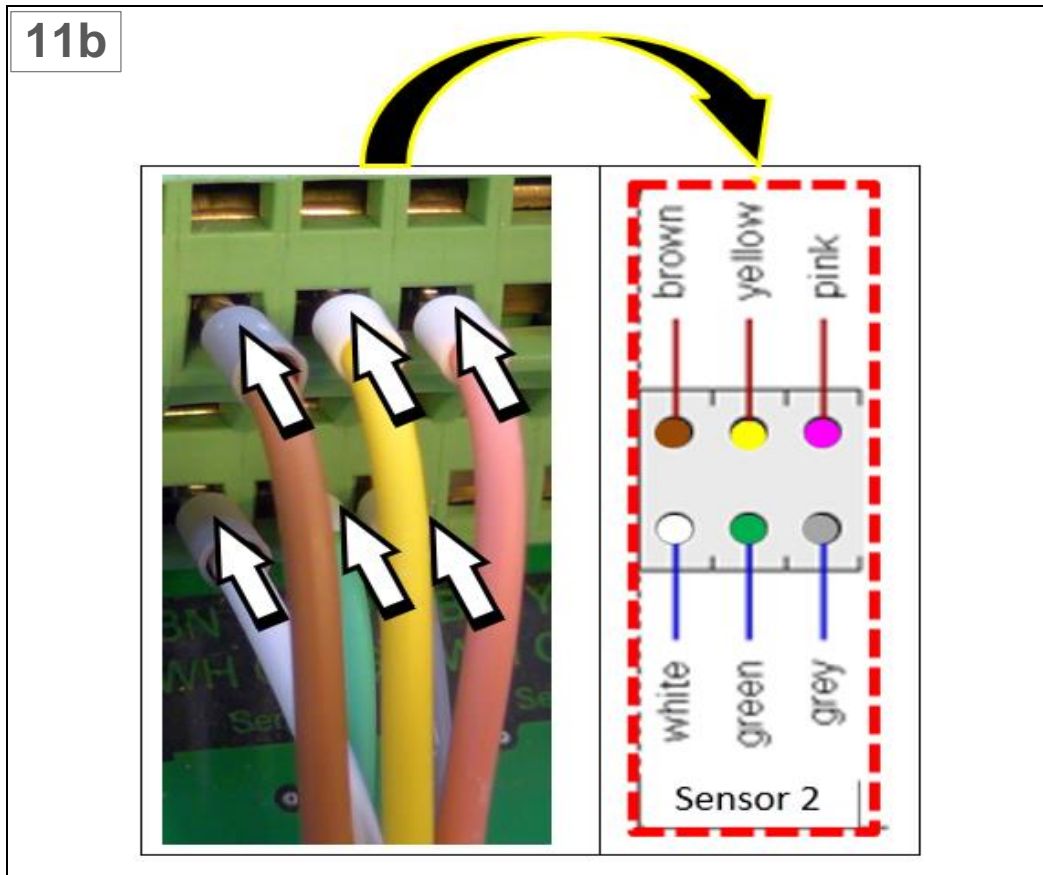

Fig.: 10 : Installation with crimping method of hybrid cable, VN301^{plus} central unit (steps 11 - 12)

1: Secure the single wires with cable ties on the cable tie retaining plate (**do not secure the compressed air hose**)

2: Cable tie retaining plate
3: Pneumatic hose

**NOTE****Functional failure of the hybrid cable as the result of incorrect installation**

For proper functioning of the oil mist detection system, the hybrid cable must be installed in accordance with the manufacturer's specifications.

The following applies in all cases:

- ▶ The pneumatic hose [③] must not be fixed to the cable tie retaining plate or similar using cable ties. (Fig. 10)
- ▶ The pneumatic hoses must be installed correctly and in accordance with the manufacturer's instructions as shown in Fig. 9!

**DANGER****Malfunction**

Operating the device with a malfunction creates a risk of death and may cause environmental damage and/or damage to the device.

- ▶ The device must be taken out of operation immediately in the event of a malfunction.

d) Locking the VN301^{plus} central unit after completing the electrical installation

After the electrical installation is complete, the central unit is closed again as per the figure below.



NOTE

Remove cable ties

- ▶ Note on step 1: Completed by removing the cable ties.

Closing the central unit

- ▶ Note on step 3: A torque spanner (size PH2) is used to close the central unit. Tightening torque: **3 Nm**

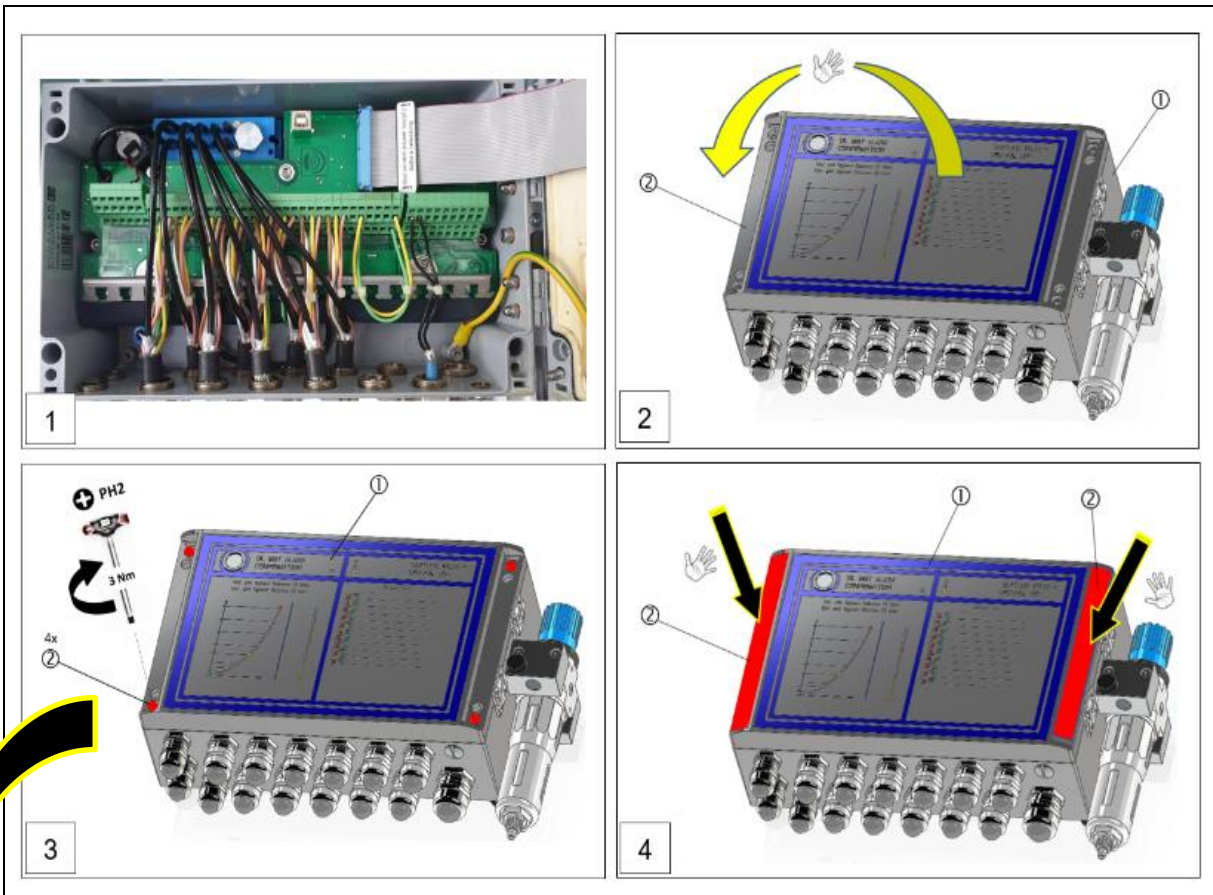
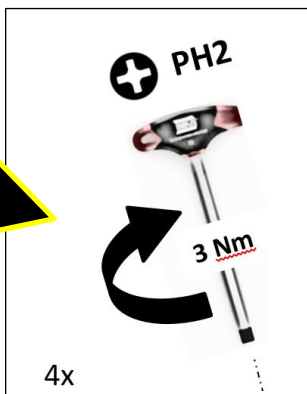

Fig.: 11 : Close the VN301plus central unit (steps 1 - 4)



3.1.4 Important note on installing the hybrid connector to the VN301^{plus} sensor unit

The electrical and pneumatic connection between the VISATRON® VN301^{plus} central unit and the sensor unit is established as per the installation steps in Section 6.4.2 (variant 1) and 6.4.3 (variant 2) of the currently valid version of the VISATRON® VN301^{plus} / VN301^{plus} EX operating manual. ⇒ Section 1.5 Applicable documents and regulations



Fig.: 12 : Hybrid cable unit, VN301^{plus}

1: Hybrid cable

3: Free cable end

2: Hybrid connector (variant 1/variant 2)



NOTE

Two variants of the hybrid cable for the VISATRON® VN301^{plus} / VN301^{plus} EX system are available.

Variant 1*): Hybrid cable with standard hybrid connector (bayonet lock)

⇒ Section 6.4.2 Electrical and pneumatic connection of the sensor unit (standard)

Variant 2*): Hybrid cable with optional hybrid connector (screw sleeve lock)

⇒ Section 6.4.3 Electrical and pneumatic connection of the sensor unit (optional)

*) : See the VISATRON® VN301^{plus} / VN301^{plus} EX operating manual



IMPORTANT INFORMATION

Potential damage to the hybrid connector of the VN301^{plus} sensor unit from installing incorrectly

- ▶ The hybrid connector on the sensor unit is locked manually.
- ▶ **The manufacturer prohibits the use tools (e.g. pliers) to lock the hybrid connector.**
- ▶ If the hybrid connector is damaged and cannot be repaired, we recommend replacing the front part of the hybrid connector.
⇒ Section 3.1.5 Replacing the hybrid connector on the hybrid cable



DANGER

Risk of oil mist explosion from impairment of the function of the VN301^{plus} sensor unit

- ▶ Installing and locking the hybrid connector to the sensor unit incorrectly can lead to failure of the applicable sensor unit and therefore represents a potential hazard from oil mist explosion.

3.1.5 Replacing the hybrid connector on the hybrid cable

The following steps for replacing the hybrid connector are for the following hybrid connector variants:

- Standard variant, hybrid connector with quick-release lock (Schaller part number 273201)
- Optional variant, hybrid connector with screw lock (Schaller part number 273200)

To replace the hybrid connector, carry out the following steps:

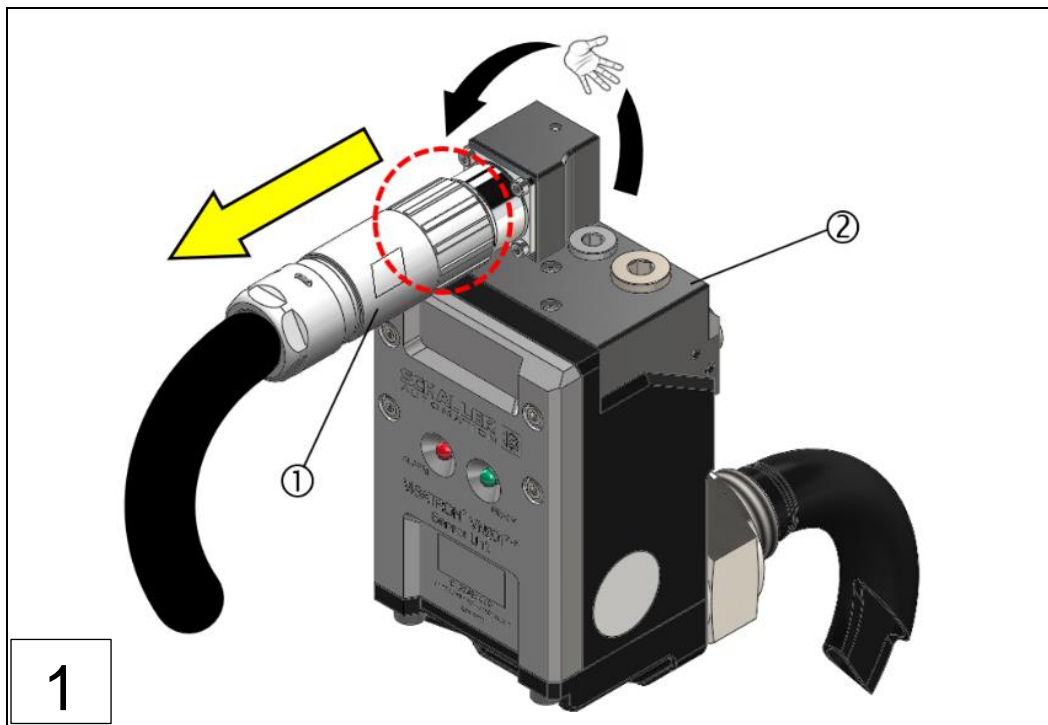

1: Hybrid connector

2: VN301^{plus} / VN301^{plus} EX sensor unit

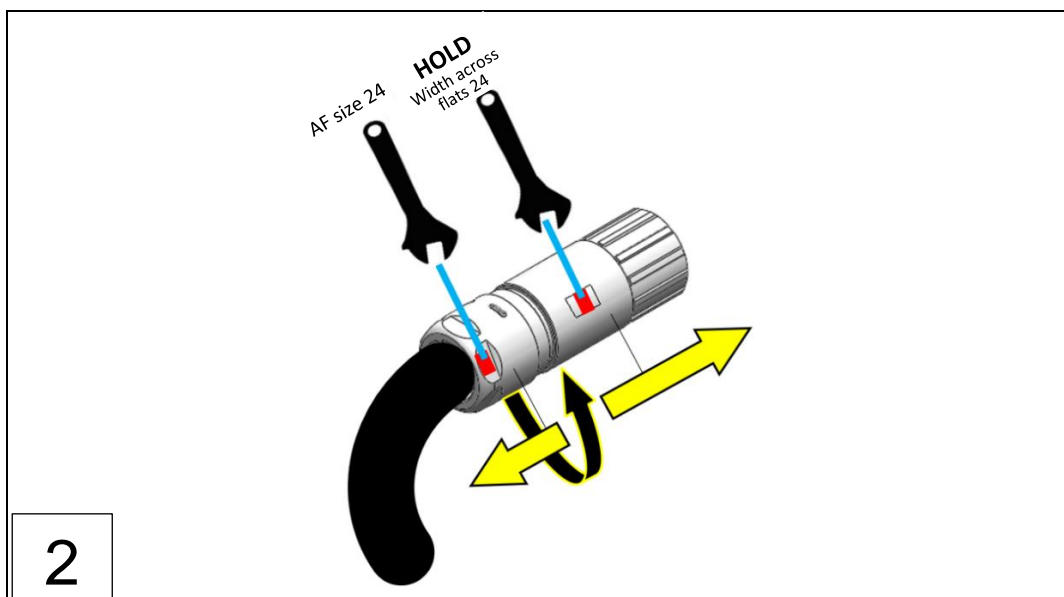

2

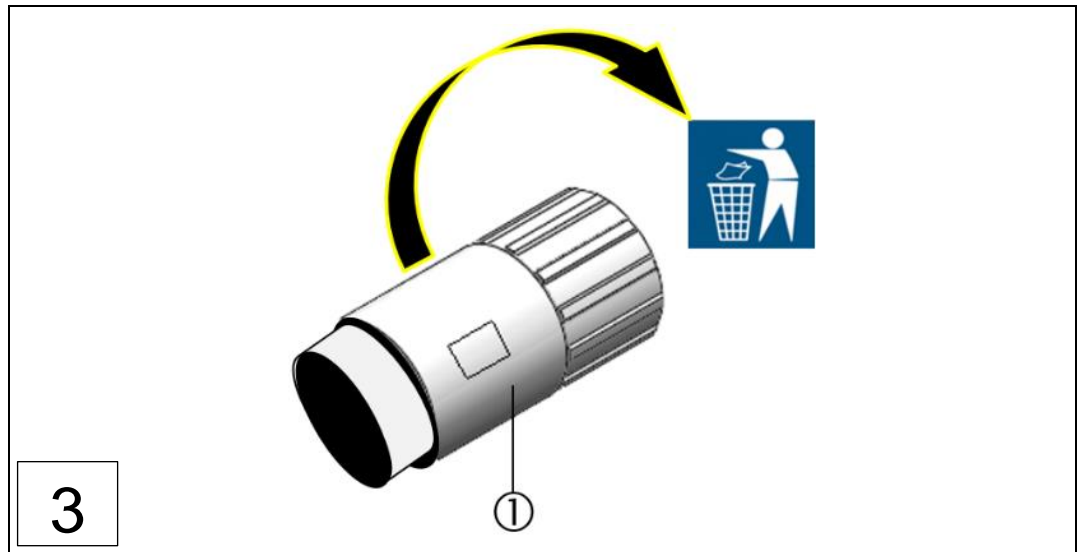

1: Locking sleeve, hybrid connector (old)

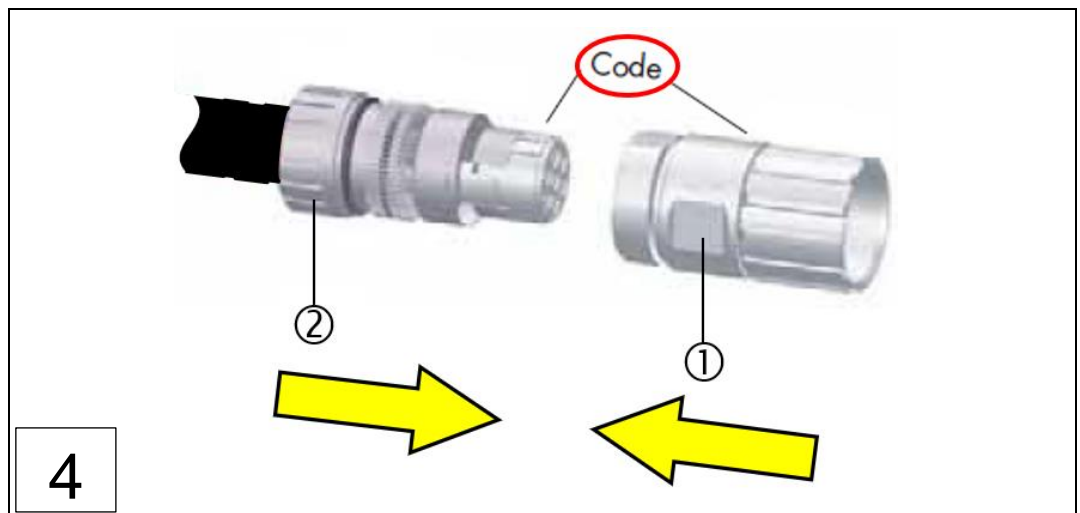

1: Locking sleeve, hybrid connector (new)

2: Connector insert, complete

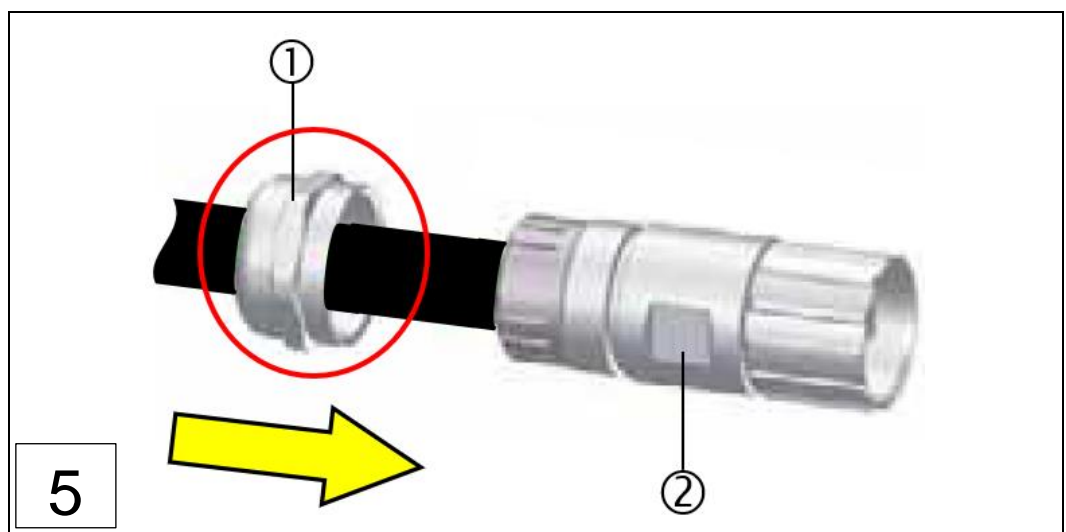

1: Cap nut

2: Hybrid connector (new)

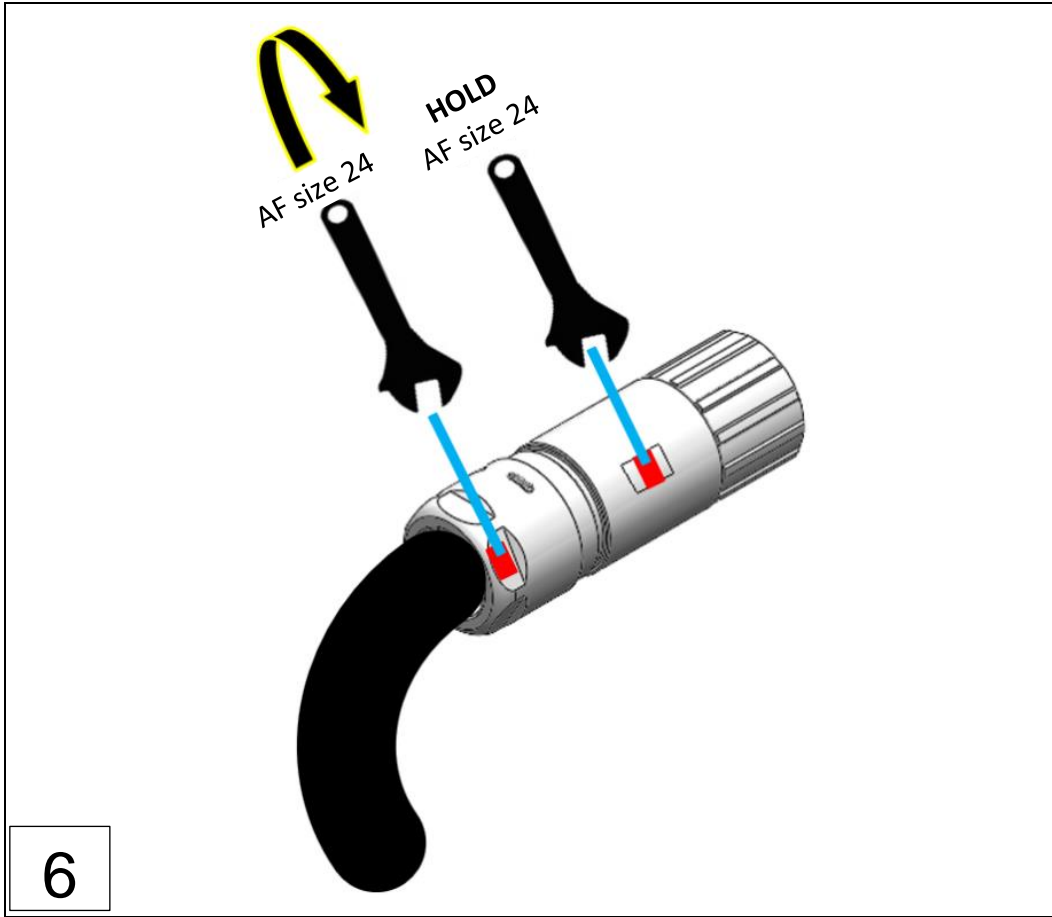

6

NOTE



Mechanical safety

- ▶ Tighten the cap nut [①] onto the block as described in step 6.

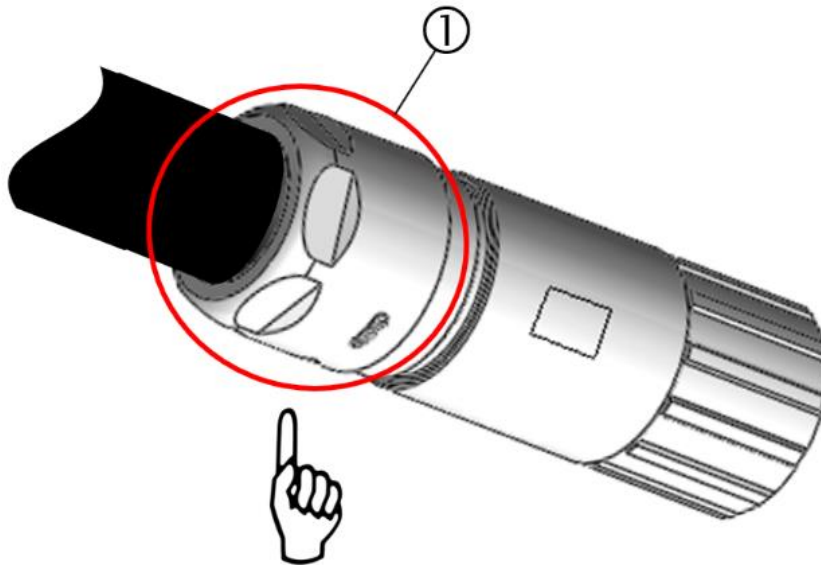

Installing the standard variant, hybrid connector with quick-release lock (Schaller part number 273201)

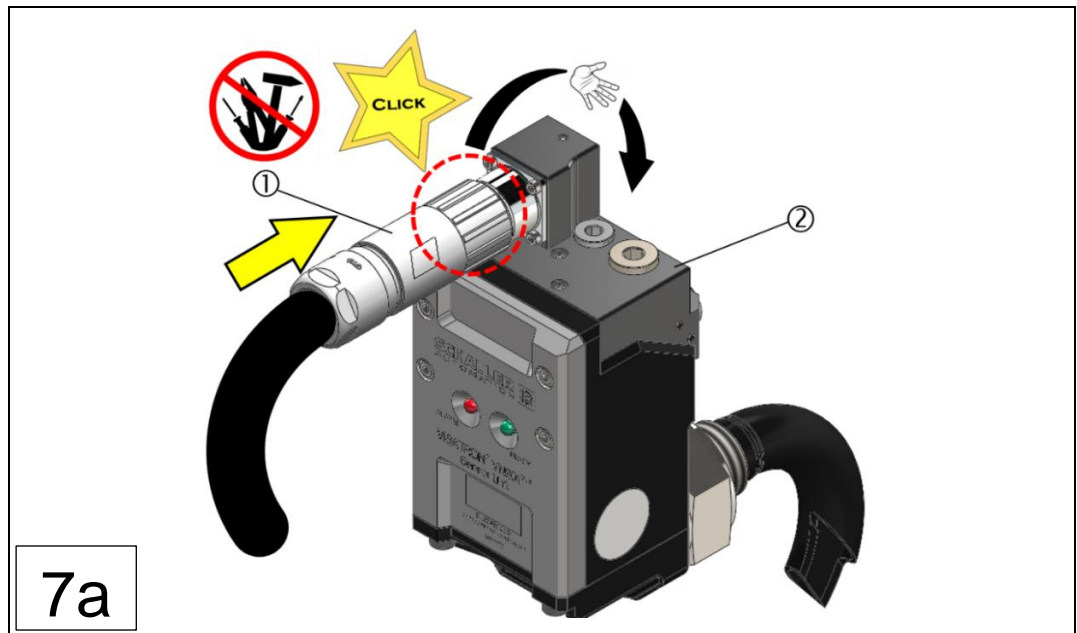

1: Hybrid connector (quick-release lock)

2: VN301^{plus} / VN301^{plus} EX sensor unit

Installing the optional variant, hybrid connector with screw lock (Schaller part number 273200)

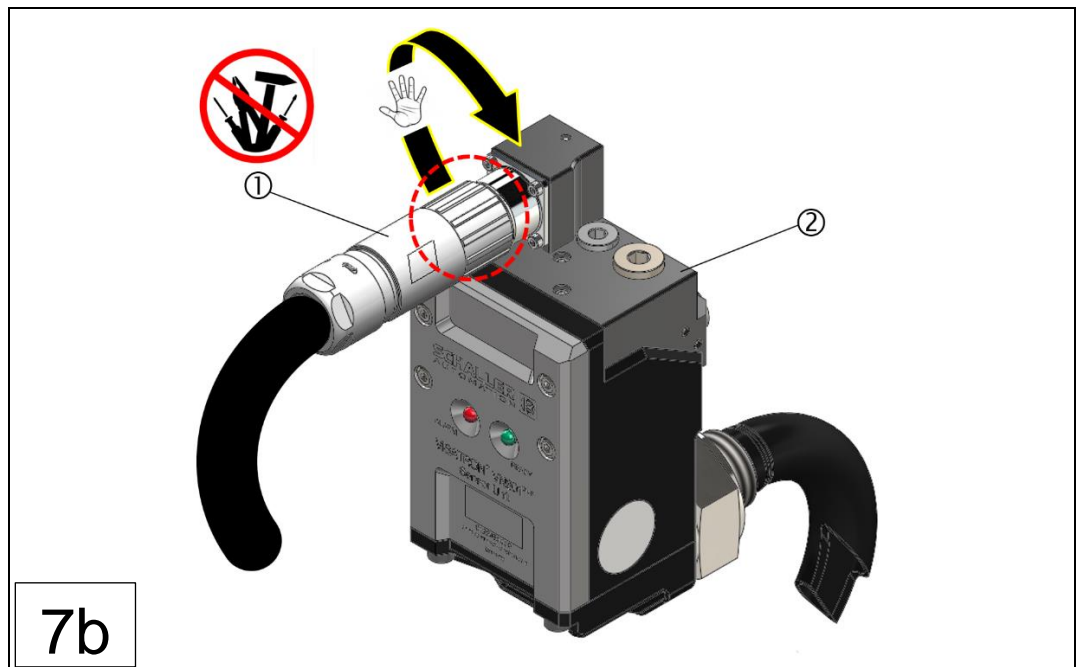

Fig.: 13 : Replacing the hybrid connector (standard/optional) (steps 1-7 a-b)

1: Hybrid connector (screw lock)

2: VN301^{plus} / VN301^{plus} EX sensor unit

The sensor unit is ready for operation!

3.2 Establishing the compressed air supply provided by the customer

The compressed air supply must be provided by the customer up to the VN301^{plus} central unit and a compressed air quality according to ISO 8573-1:2010 – 6-4-4 must be guaranteed. The compressed air supply may vary between 4-12 bar for optimum operation.



⚠ WARNING

Mild to severe bruising when handling compressed air
Risk of injury from whipping of the compressed air hose line.

- ▶ Before connecting the supply pressure, check the applied system pressure.



NOTE

Recommendations for the compressed air supply according to Figure 14

- ▶ The manufacturer recommends using flexible cables (3) for the compressed air supply to the central unit.
- ▶ The manufacturer recommends fitting an additional pressure shut-off valve (2) between the central unit and the compressed air line.

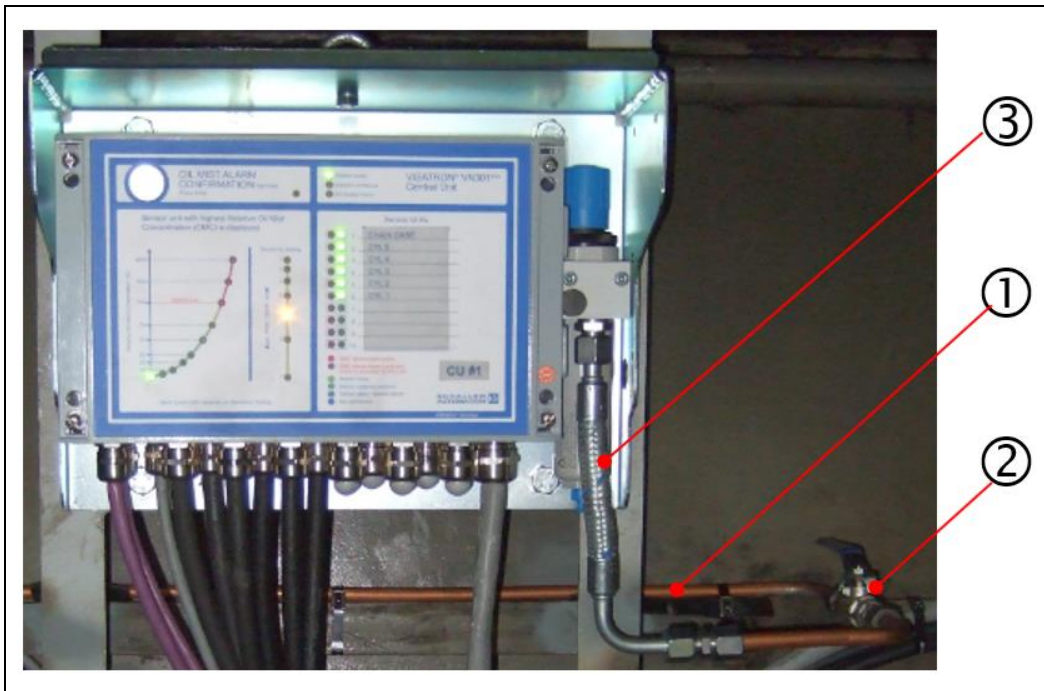

Fig.: 14 : Example of an optimum compressed air supply to the VN301^{plus} central unit

- 1: Rigid compressed air supply line
- 2: Pressure shut-off valve (recommended)
- 3: Flexible compressed air line (recommended)

The central unit is ready for operation!

3.3 Installation space and dimensions for the VN301^{plus} sensor unit



NOTE

Installation space recommendations for optimum installation and operation

- ▶ The manufacturer defines minimum installation space dimensions for optimum installation and operation of the sensor units as per the following figures.



DANGER

Accumulation of dangerous gas concentration at the sensor unit, for dual-fuel or gas engines

There is a risk of serious injury, including death, due to accumulation of dangerous gas concentrations at the sensor units in the engine room as a result of incorrect assembly or installation. The following instructions must therefore be observed, in particular for the installation of sensor units in potentially explosive atmospheres:

- ▶ The sensor unit must **not** be installed in a recess that could allow gas to accumulate!
- ▶ The sensor unit must **not** be given an enclosure by the customer!



3.3.1 Installation space and dimensions for the “Horizontal” VN301^{plus} sensor unit

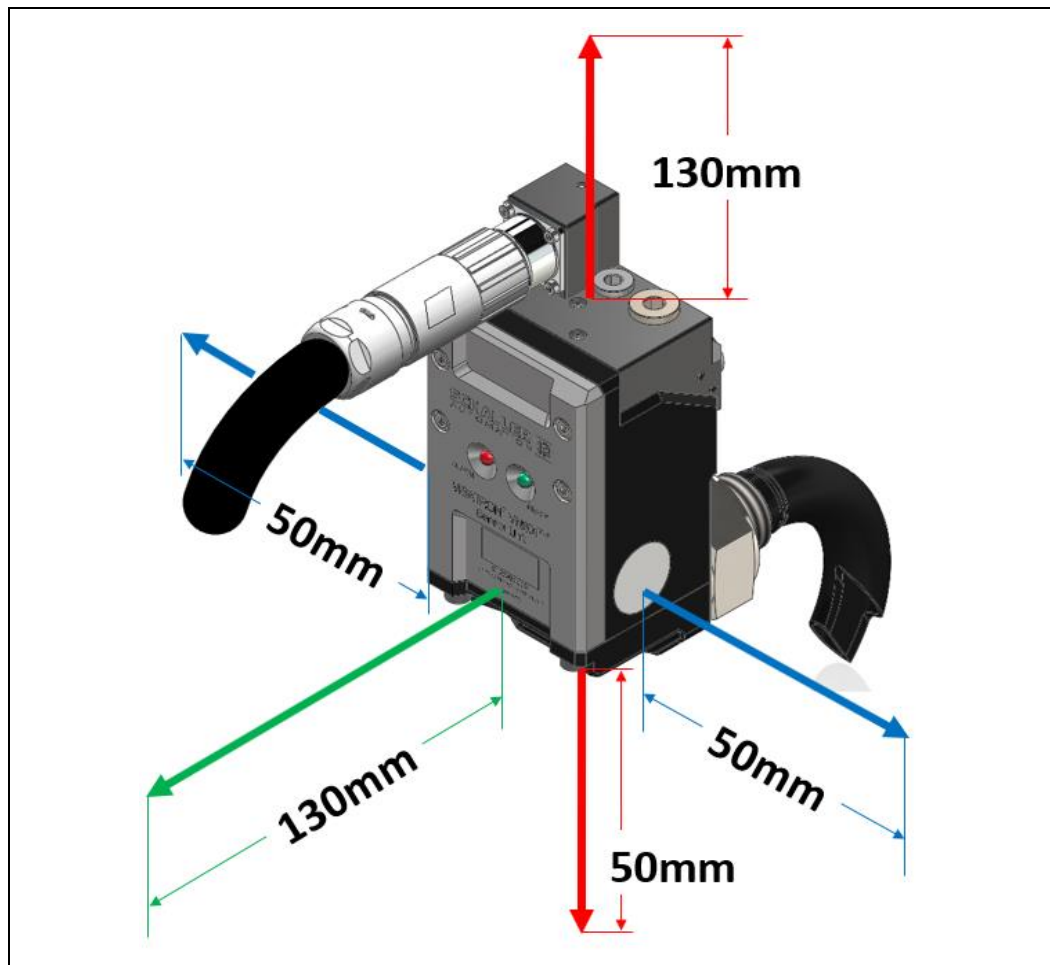

Fig.: 15 : Installation space and dimensions for the “Horizontal” VN301^{plus} sensor unit

3.3.2 Installation space and dimensions for the “Vertical” VN301^{plus} sensor unit

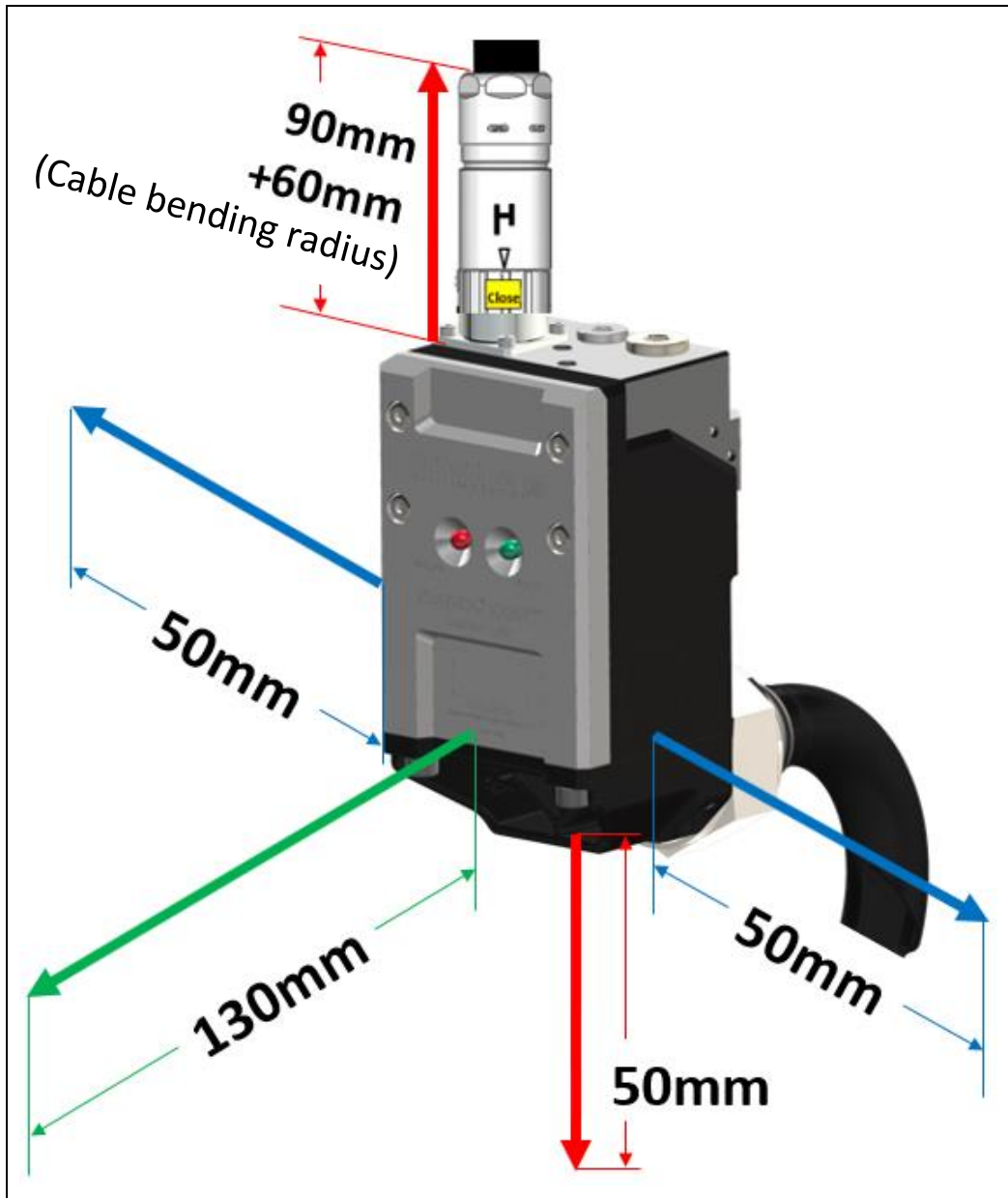

Fig.: 16 : Installation space and dimensions for the “Vertical” VN301^{plus} sensor unit

3.3.3 Installation space and dimensions for the “Left” VN301^{plus} sensor unit

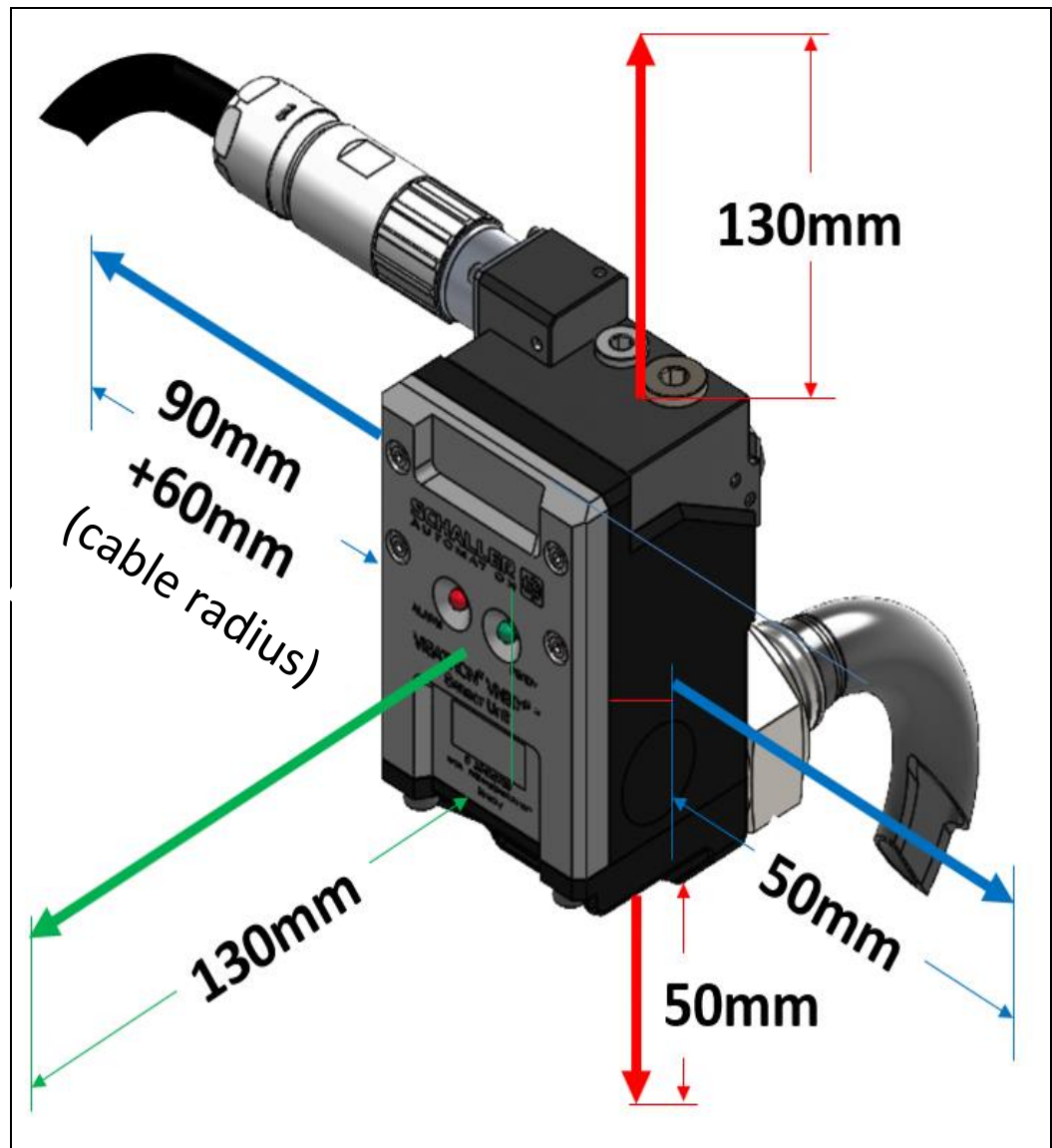

Fig.: 17 : Installation space and dimensions for the “Left” VN301^{plus} sensor unit

3.3.4 Installation position for the VN301^{plus} sensor unit

NOTE

Premature contamination of the oil mist detection system

- ▶ The allowed installation tolerance of the sensor unit is +/- 3 degrees deviation from the horizontal alignment. (deviation from the horizontal alignment)

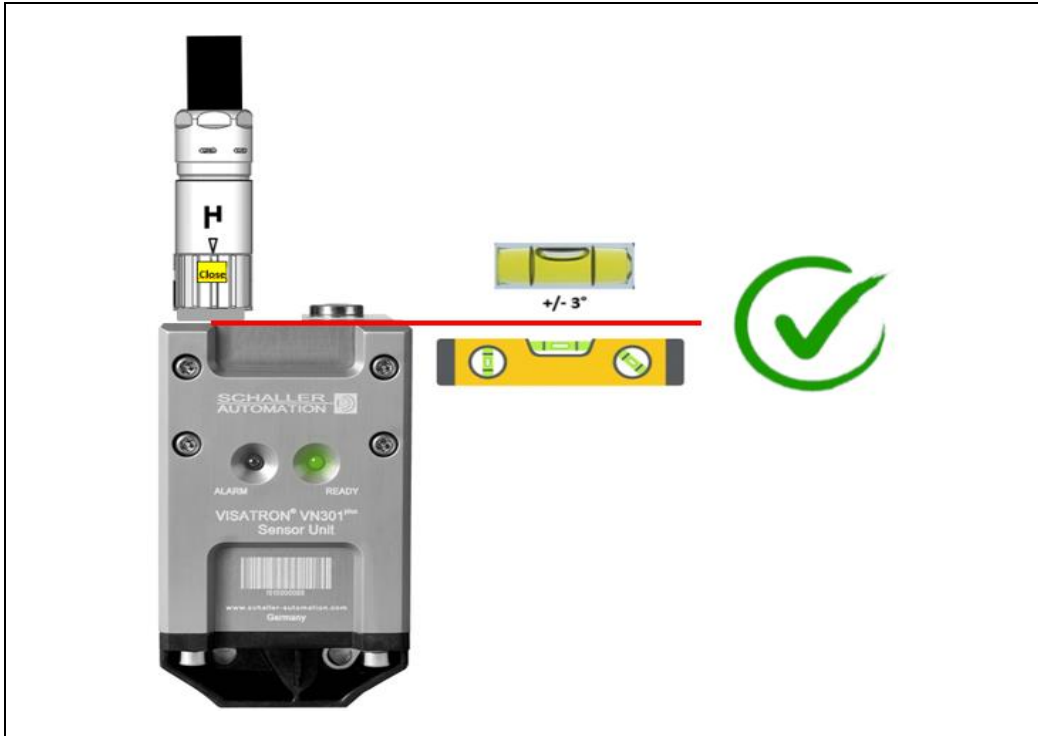

Fig.: 18 : Correct installation position for the VN301^{plus} sensor unit

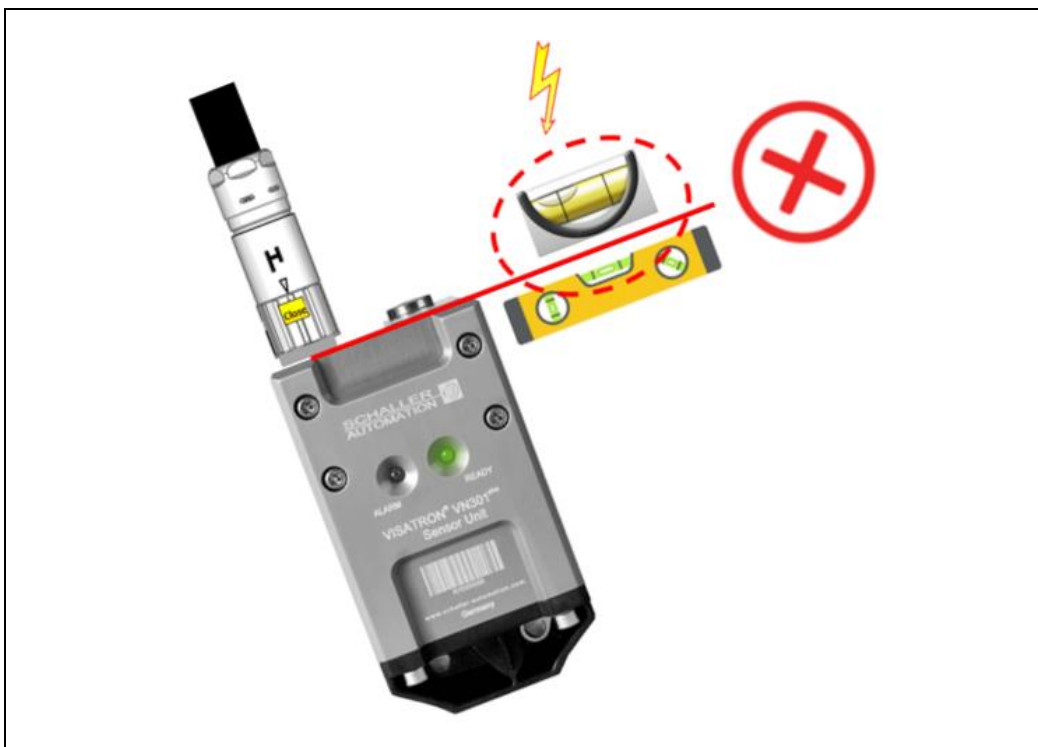

Fig.: 19 : Incorrect installation position for the VN301^{plus} sensor unit

3.4 Installation space and dimensions for the VN301^{plus} central unit



NOTE

Installation space recommendations for optimum installation and operation

- ▶ The manufacturer defines minimum installation space dimensions for optimum installation and operation of the central unit as per the following figure.

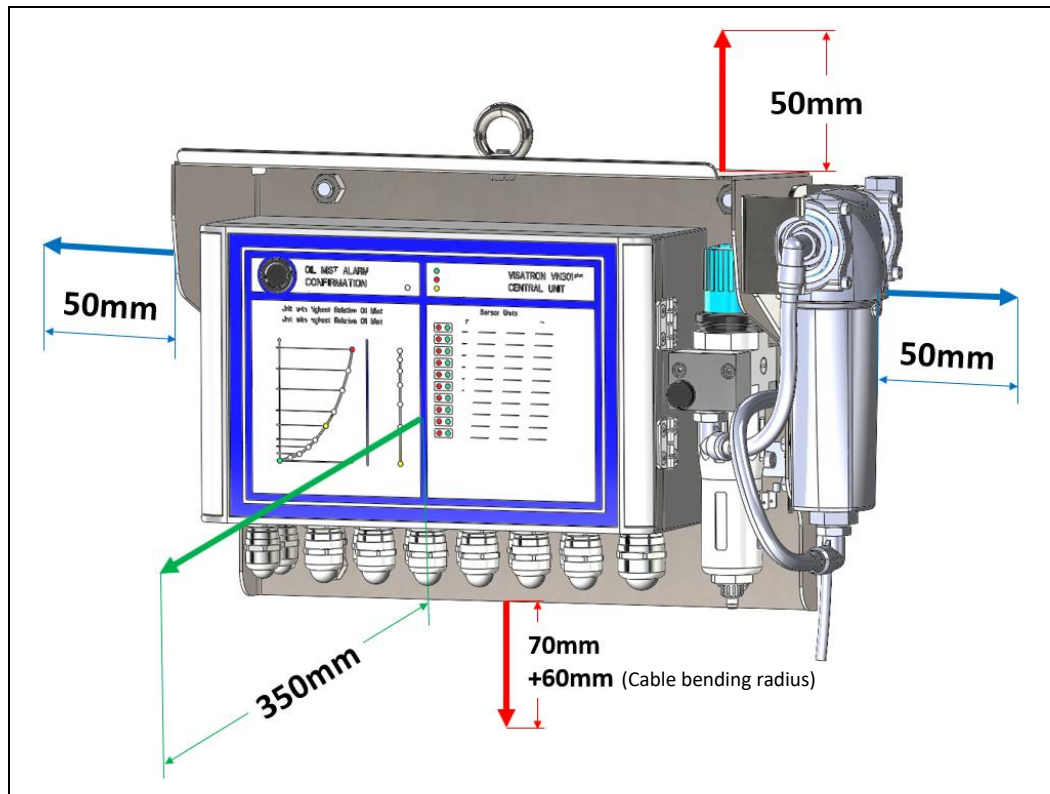

Fig.: 20 : Installation space and dimensions for the VN301^{plus} central unit

4 Contact

You can use the following contact details to contact customer service at Schaller Automation Industrielle Automationstechnik GmbH & Co. KG:

SCHALLER Automation (Headquarters)
Industrielle Automationstechnik GmbH & Co. KG
Industriering 14
66440 Blieskastel, Germany
Phone: +49 6842 508 0
Fax: +49 6842 508 260
Email: info@schaller.de
Website: www.schaller-automation.com

Schaller Automation LP
811 Shotgun Road
Sunrise, FL 33326
United States of America
Phone: +1 954 794 1950
Mobile: +1 561 289 1495
Fax: +1 954 794 1951
Email: info@schalleramerica.com

Schaller Automation Pte Ltd.
114 Lavender Street
#09-93 CT Hub 2
Singapore 338729
Phone: +65 6643 5151
Mobile: +65 9788 7550
Fax: +65 6643 5150
Email: info@schallersingapore.com
Website: www.schaller.sg

Schaller Automation – China
Room 401, Juyang Mansion No. 1200
Pudong Avenue,
Shanghai 200135, P.R.China
Phone: +86 21 5093 7566
Mobile: +86 1390 1890 736
Fax: +86 21 5093 7556
Email: info@schallerchina.cn



You can also find all our certified partners on our homepage at:

<https://schaller-automation.com/partner/>



OUR PASSION. YOUR SAFETY.

- since 1956 -