

GasMOS[®]2020

Gas monitoring system



Selective online measurement of gas concentrations in large engines

SCHALLER 
AUTOMATION

Schaller Automation Pte Ltd
114 Lavender Street #09-93 CT Hub 2
Singapore 338729

Phone : +65 6643 5151 
WhatsApp : +65 9788 7550 

info@schallersingapore.com



biSAFE
S T P C R

www.schaller.sg

Product description

The steadily growing number of LNG-fuelled engines as a consequence of challenging emissions regulations creates another possible cause of crankcase explosions: methane. The unburnt methane enters via the top land and the piston sealing rings through blow-by effects either into the crankcase directly or the area under the pistons and can accumulate in the combustion chamber in concentrations up to higher than the lower explosion limit, depending on the fuel-air mixture.

GasMOS® is a monitoring system that increases safety by detecting the methane content in the crankcases of gas and dual-fuel engines on ships and in power stations.

The system design combines measurement technology and gas suction in a highly compact way and is modular. The concept explicitly provides for installation away from the engine to take into account aspects such as vibration, the effort required for installation and easy accessibility for maintenance. The system is connected to the engine crankcase by cable and is protected against contamination from the crankcase atmosphere by appropriate filtering.

Flexible communication: The system comes with modern fieldbus interfaces such as CAN and Modbus. It is easy to read messages and status information from the front panel.



- **Withstands the extreme environmental conditions at the engine**
- **Highly accurate measurements as there are no cross-sensitivities to other gases**
- **Active gas intake**
- **Modular measuring unit**
- **Automatic zero point adjustment**

How it works

The GasMOS® uses a multi-sensor system in combination, taking into account other factors such as temperature, humidity and pressure, to analyse the crankcase atmosphere, creating a multi-dimensional database for methane detection. Using special algorithms makes it possible to suppress the disturbance variables as far as possible and detect the methane for measurement very selectively and robustly.

The crankcase atmosphere is actively fed to the sensors via an intake, ensuring reliable and rapid detection of changes in concentration. To compensate for long-term offset drift and to stabilise the measurement signal, regular adjustment is carried out using ambient air.

Application

The GasMOS® has been developed to measure methane gas concentrations in crankcases. This type of measurement is used in dual-fuel and gas engines with crankcases in which critical methane gas concentrations can occur as a result of blow-by via the piston rings or abnormal operating conditions. It is used primarily on ships and in power stations.

Thanks to its robust design, the GasMOS® can be used to measure methane under harsh operating conditions.

Its algorithm-based analysis methods means that it can be used to selectively detect methane regardless of the gas composition.

Thanks to its modern software solution, the GasMOS® can be connected to any CAN/Modbus system.

The GasMOS® is therefore a modern state monitoring system for continuously recording and assessing the methane concentration.

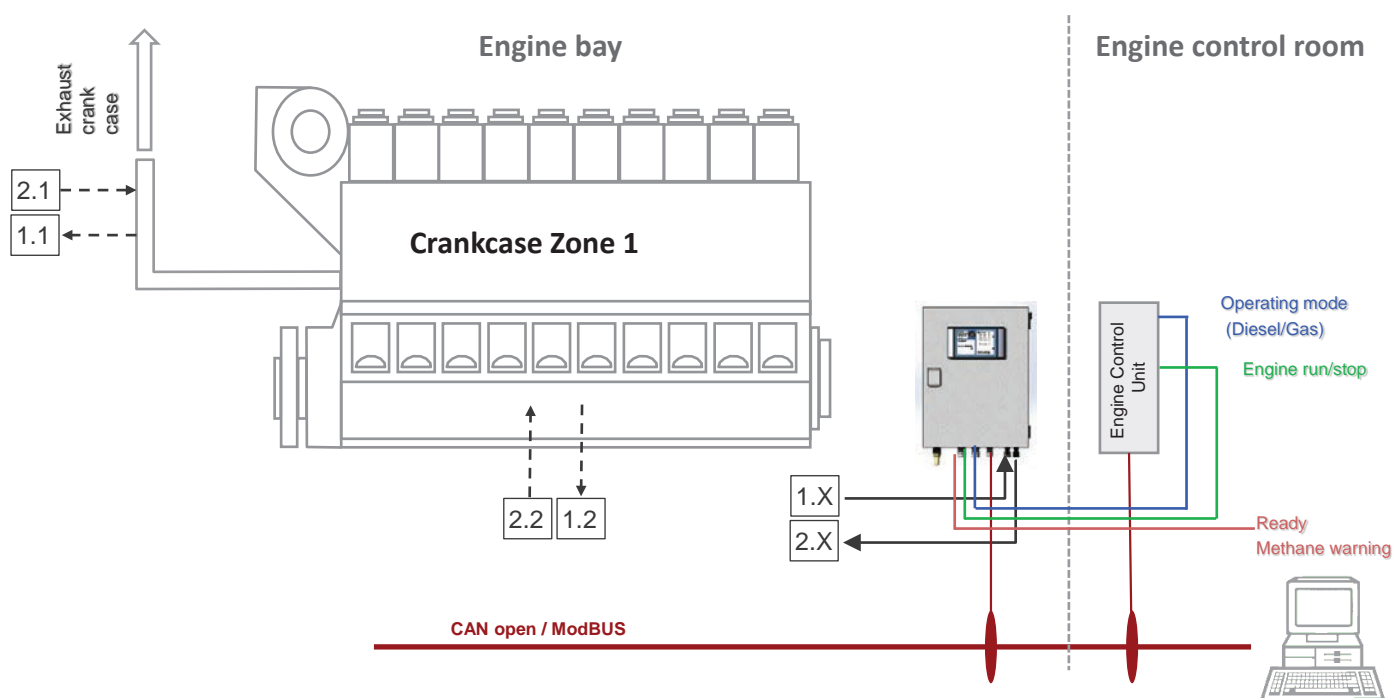

Advantages and benefits

- Continuous methane measurement
- Accurate measurement by using suitable sensors
- Self-monitoring
- Best-in-market calibration interval (12 months)
- Automatic adjustment of measured values using fresh air
- Easy maintenance and quick replacement thanks to modular system architecture

Technical data

Dimensions	Approx. 310 x 450 x 175 mm
Weight	13.00 kg
Power supply	18 – 31.2 V DC; $U_{\min} < U_{\text{Supply}} < U_{\max}$
Nominal voltage	24 V DC
Communication interface with monitoring device	3-wire RS485, electrically isolated <u>or</u> CANopen, electrically isolated
Ambient temperature range	0 to 50 °C
Protection rating	IP 54
Pressure ratio in the crankcase	-50 mbar to +50 mbar
Measuring range and accuracy	0- 3.8% by volume with a measuring accuracy of $\pm 10\%$ LEL 0.44% by volume



Safety for you and your engine: Worldwide!

Headquarters:

SCHALLER Automation

Industrielle Automationstechnik GmbH & Co. KG
Industriering 14
66440 Blieskastel, Germany
Phone: +49 6842 508 0
Fax: +49 6842 508 260
Mail: info@schaller.de
www.schaller-automation.com

China

Schaller Automation- China
Room 401, Juyang Mansion
No. 1200 Pudong Avenue,
Shanghai 200135, P.R.China
Phone: +86- 21- 5093- 7566
Mobile: +86- 1390- 1890- 736
Fax: +86- 21- 5093- 7556
Mail: info@schallerchina.cn

Key Account Management Center:

Singapore

Schaller Automation Pte Ltd.
114 Lavender Street
#09-93 CT Hub 2
Singapore 338729
Phone: +65 6643 5151 (24/7)
Fax: +65 6643 5150
Mail: info@schallersingapore.com



USA

Schaller Automation LP
811 Shotgun Road
Sunrise, FL 33326
United States of America
Phone: +1 954 794 1950
Mobile: +1 561 289 1495
Fax: +1 954 794 1951
Mail: info@schalleramerica.com



ISO 9001/2015 certified

GasMOS® is a registered trademark of Schaller Automation GmbH & Co. KG