

# The key for Predictive Maintenance Acceleration Monitoring System-ACCOMOS®

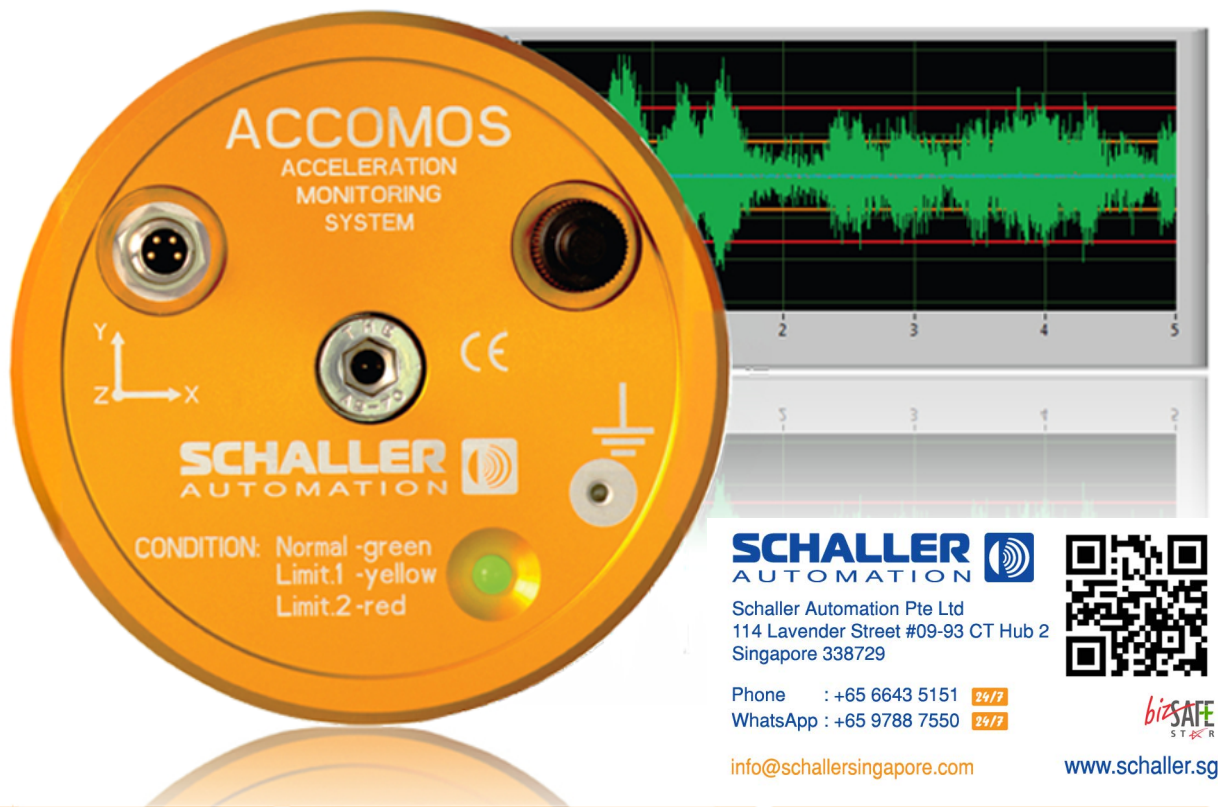

The image shows the ACCOMOS Acceleration Monitoring System, a circular orange device with a central screw, a green LED indicator, and a CE mark. It features a 3-axis coordinate system (X, Y, Z) and a status indicator. The device is shown next to a software interface displaying a green waveform on a black background with red and yellow horizontal lines representing limits. The software interface also shows a numerical scale from 2 to 5.

**ACCOMOS**  
ACCELERATION  
MONITORING  
SYSTEM

Y  
Z  
X



CE

**SCHALLER**   
AUTOMATION

CONDITION: Normal -green  
Limit.1 -yellow  
Limit.2 -red

**SCHALLER**   
AUTOMATION

Schaller Automation Pte Ltd  
114 Lavender Street #09-93 CT Hub 2  
Singapore 338729

Phone : +65 6643 5151   
WhatsApp : +65 9788 7550 





info@schallersingapore.com [www.schaller.sg](http://www.schaller.sg)

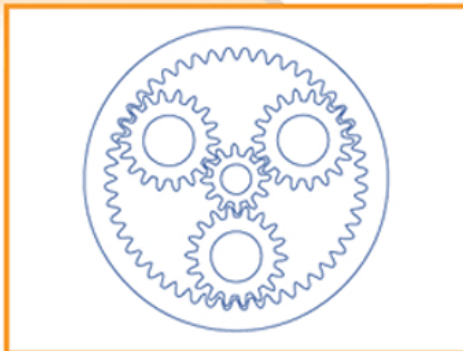
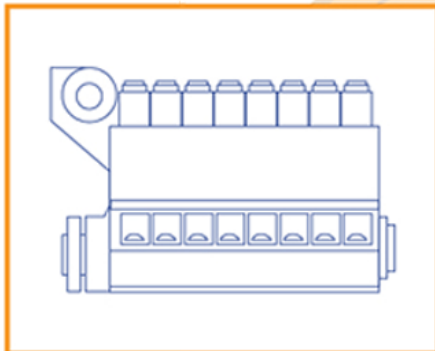

# ACCOMOS®

## Monitors vibration to prevent damages

A novel three-axis vibration sensor, specially adapted to the requirements of drive units with large engines and large wind turbines, including their components.

- Simple detection of incipient damages (e.g. on engine stands, clutches and foundations) and alignment errors with the generator or machine.
- Extremely easy installation: ultra-strong magnets allow installation of the system within minutes. In most cases, it is not necessary to machine the surfaces.
- Permanent installation allows for long-term analysis with storage of the most important data.
- A single sensor allows pre-alerts and main alerts for the vibration behaviour to be indicated with a colour LED on the sensor and in the software.
- It is possible to transfer the real-time data to the monitoring software via CAN or RS485 protocol. Display and storage of real-time data in all three axes, plus display of the frequency spectrum.



- The software offers a teach-in function, that enables the thresholds for pre-alerts and main alerts on the monitored machine to be determined.

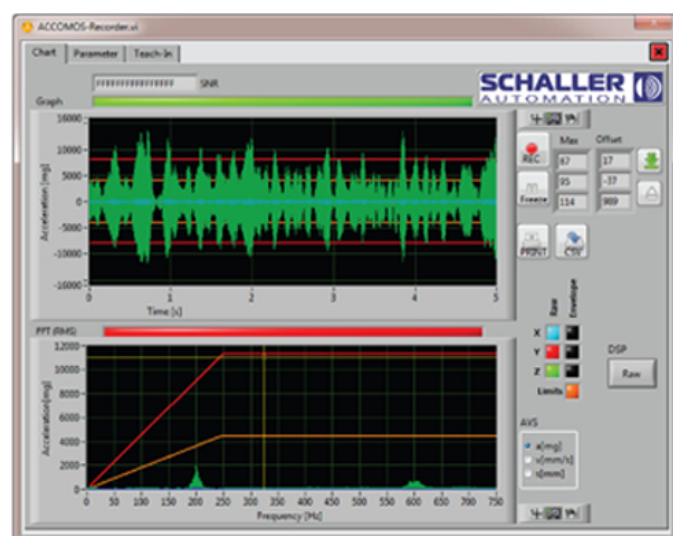

- One sensor for three axes
- Early detection of incipient damages
- Permanent installation possible in minutes
- Software with teach-in function
- RS485 or CAN protocol

# Engine Vibration Classification

ACCOMOS is ideal for ensuring the Engine Vibration Classification is adhered to according to the globally applicable DIN ISO 10816-6 standard for engines > 100 kW.

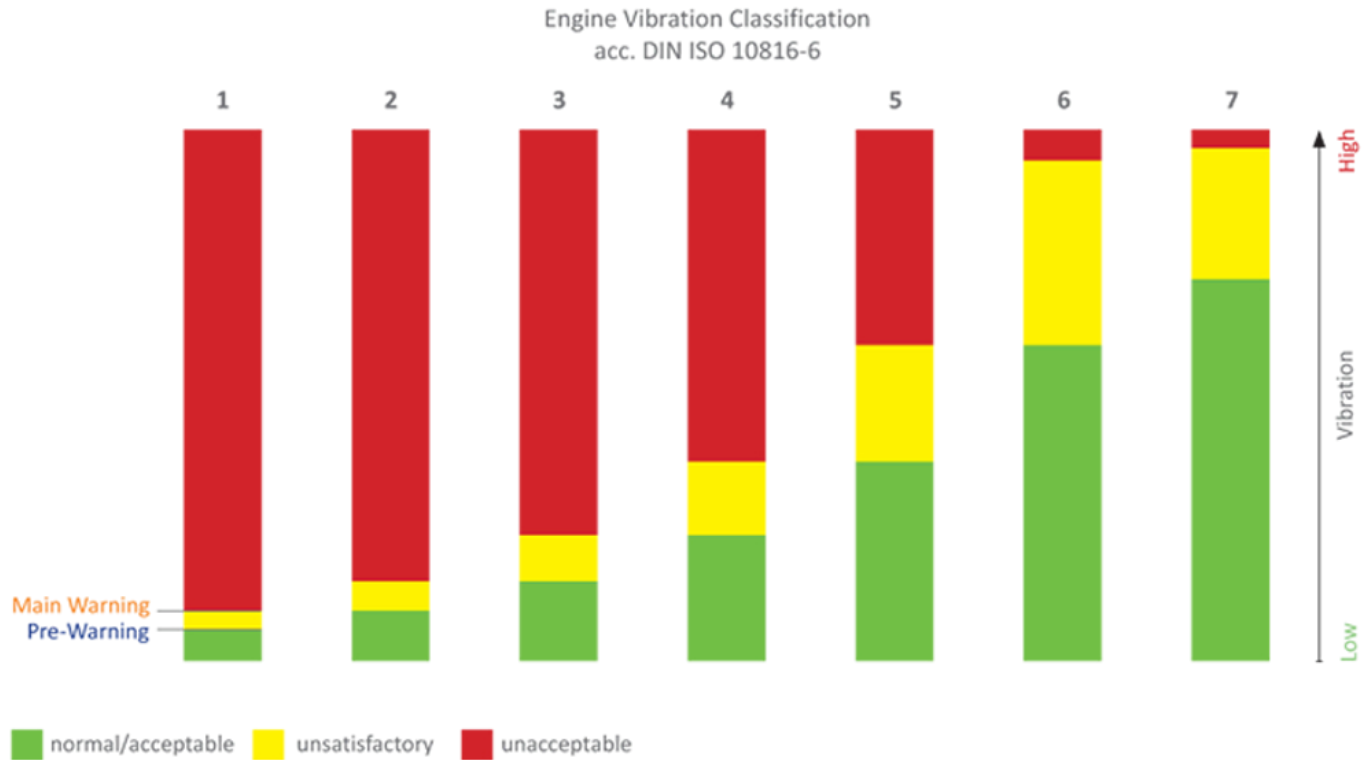

## Set Up

Standard accessories may be used for the CAN connection, when available.

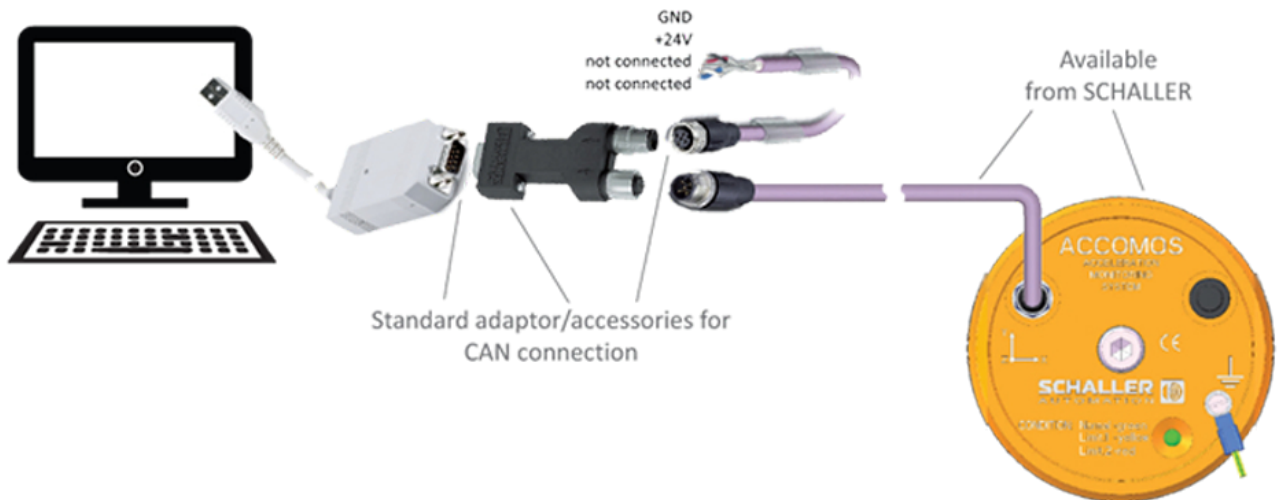

# Teach-In-Function

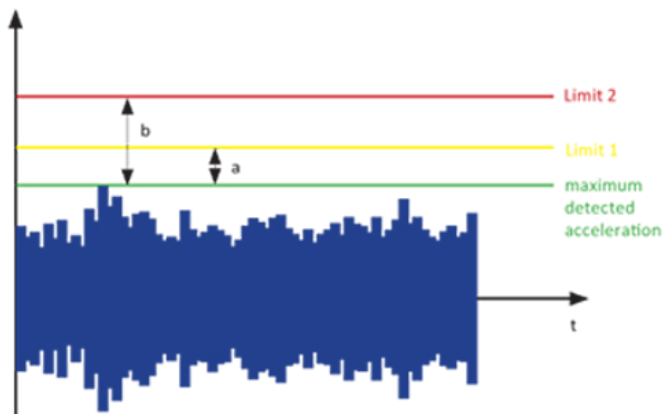

a: value added to define Limit 1  
b: value added to define Limit 2

The teach-in function is a particularly method to set the parameters in the sensor according the monitored machine:

- Thresholds for the "Limit 1" and "Limit 2" values are generated automatically by ACCOMOS®.
- To do this, a monitoring period (e.g. 5 days) needs to be performed, the maximum measured value is specified automatically as the OK value. Safety margins may be applied to prevent false alarms.
- If the set limit has been exceeded, it will be displayed in the recorder software and on the sensor.
- Corresponding signals can also be output via the sound card of the computer.

## Software

The ACCOMOS Recorder Software allows for the following to be displayed:

- Live signal
- Maximum trend curve
- Frequency spectrum of the acceleration signal on the ACCOMOS sensor.

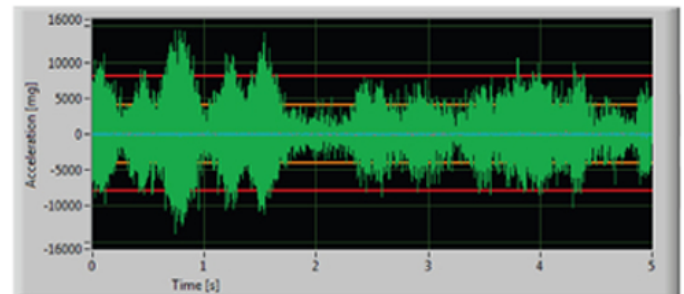

Live signal of the sensor, in this case in mg over time

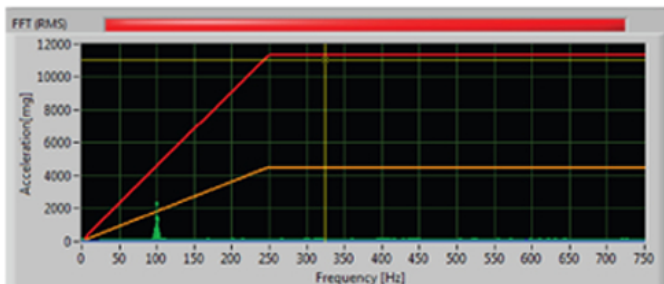

A FFT frequency analysis is also permanently displayed

In order to signal critical accelerations, the ACCOMOS software has colour indicators that light up yellow or red when the thresholds are exceeded. Additionally, an alarm signal can be output via the sound card in such cases.

The maximum trend curve is saved automatically in the background, as the cases where the limits have been exceeded (including time stamp). The software also allows the recording of the live signal, to be initiated manually.

## Technical Data Sensor

Power supply	9 – 36 VDC
Consumption	Max. 110mA
Temperature range	-25 °C bis +85 °C
Measure range	+/- 16,000mg
Frequency range	0 – 750Hz (1500Hz for CAN BUS possible)
Sensitivity	4 mg
Data transfer	Digital via RS485 or CAN
Height incl. plug	80mm
Weight	400g
Diameter	89,5mm

The following minimum system requirements apply for the software:

Microsoft Windows 7 with Service Pack 1
.NET Framework from Version 4
Intel Pentium Dual-Core 2.80 GHz or equivalent/better
Minimum 2 GB RAM
Minimum 3 GB hard disk space
Optional: Sound card (for acoustic signalling)
RS485 or CAN interface

## Sensor Dimensions

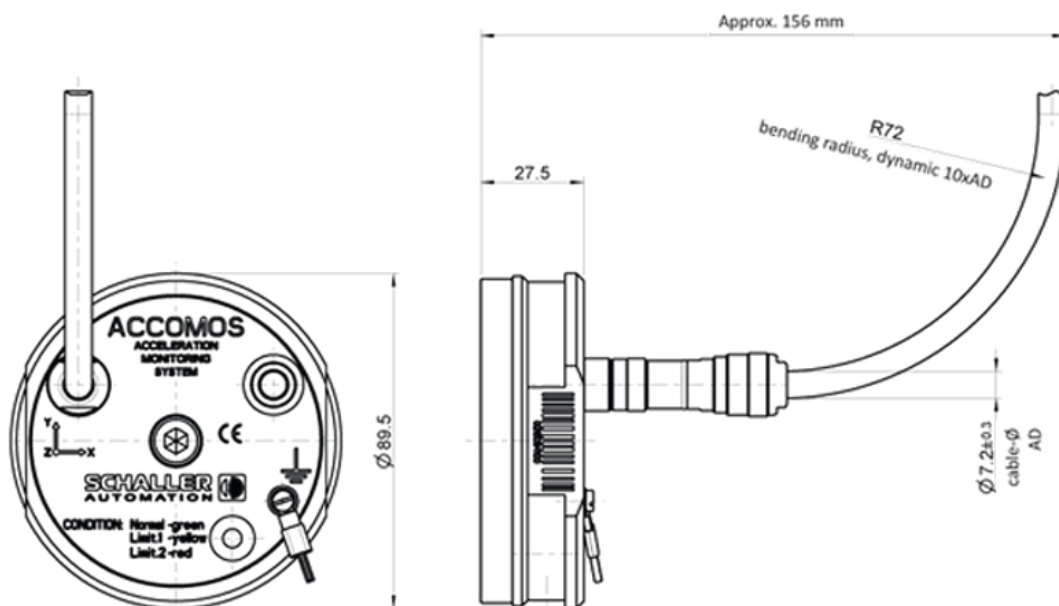



# Safety for you and your engine: Worldwide!

## Headquarters:

### SCHALLER Automation

Industrielle Automationstechnik GmbH & Co. KG  
Industriering 14  
D-66440 Blieskastel  
Tel.: +49 6842 508 0  
Fax: +49 6842 508 260  
Mail: [info@schaller.de](mailto:info@schaller.de)  
[www.schaller-automation.com](http://www.schaller-automation.com)

## Key Account Management Center:

### Singapore

Schaller Automation Pte Ltd.  
114 Lavender Street  
#09-93 CT Hub 2  
Singapore 338729  
Phone: +65 6643 5151 (24/7)  
Fax: +65 6643 5150  
Mail: [info@schallersingapore.com](mailto:info@schallersingapore.com)

### China

Schaller Automation - China  
Room 401, Juyang Mansion  
No. 1200 Pudong Avenue,  
Shanghai 200135, P.R.China  
Phone: +86-21-5093-7566  
Mobile: +86-1390-1890-736  
Fax: +86-21-5093-7556  
Mail: [info@schallerchina.cn](mailto:info@schallerchina.cn)

### USA

Schaller Automation LP  
811 Shotgun Road  
Sunrise, FL 33326  
United States of America  
Phone: +1 954 794 1950  
Mobile: +1 561 289 1495  
Fax: +1 954 794 1951  
Mail: [info@schalleramerica.com](mailto:info@schalleramerica.com)



ISO 9001/2015 certified

