

Version 2.5, 08/2017

**VISATRON®**

**Oil Mist Detectors**

**VN115/87plus**

**VN116/87plus**

**VN215/87plus**

# Operation Manual

Part-No. 180062



**IACS UR M67 type approved**

**SCHALLER**  
**AUTOMATION**



## About this Manual

This operation manual was designed to answer your questions concerning the handling, operation and maintenance of the Oil Mist Detector (OMD) VISATRON® series VN87plus. It contains no details about repairs.

The operating instructions are applicable for:

VN115/87plus  
VN116/87plus  
VN215/87plus

Should you encounter any interruption or breakdown of your VISATRON® series OMD device during operation, please contact your local representative (refer to chapter 10 'Service Partners') or Schaller Automation Industrielle Automationstechnik GmbH & Co. KG directly. The repair of OMD devices should be carried out by Schaller Automation directly or by a repair center dedicated and authorized by Schaller Automation. You can expect safe and reliable operation of your OMD only when the device is operated in accordance with this manual.

Please take note of the following:

- Please read this manual thoroughly and acquaint yourself with the correct installation, operation and maintenance of your VISATRON® series VN87plus device.
- Installations of the VISATRON® series VN87plus devices have to be in accordance to the IACS UR M10 if applicable.
- Use the VISATRON® series VN87plus devices only for the purpose described in the operation manual.
- Incorrect maintenance and handling errors may cause possible device failure or an unsafe operating environment.
- The VISATRON® series VN87plus devices may only be used by authorised staff.
- This operation manual must be available at the place of installation at all times.

## Terms and conditions of sale

The standard terms and conditions of sale of SCHALLER AUTOMATION shall apply to all VISATRON® and related products.

SCHALLER AUTOMATION Industrielle Automationstechnik GmbH & Co. KG warrants that under proper use, handling and maintenance OMD VISATRON® series VN87plus is free from defects in material, design and/or workmanship. Claims of buyers/operators, in particular compensation for damage, which does not arise at OMD VISATRON® series VN87plus itself or for natural wear and tear of consumable supplies, e.g. filters etc., are excluded. SCHALLER AUTOMATION Industrielle Automationstechnik GmbH & Co. KG is not responsible for defects, which arise as a result of:

- a) natural wear and tear, improper commissioning, improper use/handling, use of unsuitable power supply, welding processes on the engine as well as non-






observance of commissioning, installation, operating and service instructions as given in this Operation Manual

- b) components and design other than the OMD VISATRON® series VN87plus
- c) alterations or modifications of the OMD VISATRON® series VN87plus carried out by the buyer/operator or third parties without written authorization of SCHALLER AUTOMATION Industrielle Automationstechnik GmbH & Co. KG
- d) incorrect combination of devices and/or components or operation of devices and/or components which are not certified to be compatible or not permitted by the manufacturer - SCHALLER AUTOMATION Industrielle Automationstechnik GmbH & Co. KG



## Safety instructions

The series VN87plus devices are manufactured according to the high quality standards of SCHALLER AUTOMATION and must pass stringent factory tests. In order to keep the device in a smooth and problem free operation, the user has to take note of the safety hints and warnings. In the instruction manual they are marked with the following symbols.

Used symbols	
	CAUTION! Do not ignore the text in this box. Personnel safety can be endangered or the device can be damaged.
	WARNING! The marked text contains important information.
	The marked text contains only a hint for faster processing.

	<b>CAUTION! Unplug the OMD during welding processes on the engine.</b>
--	--

### Reset of Oil Mist Alarms



#### CAUTION!

**Use a monitoring device at a safe location (e.g. ECR) to check for the actual oil mist concentration that is requested by the IACS. In case of an Oil Mist Alarm, Schaller Automation strongly recommends to approach the engine only after indicated oil mist concentration (LED chain) has lowered to half of its bar indication (VISATRON®-device and Remote Indicator II).**

**Follow the instructions of engine builder, ship yard and ship owner!**

**In case of a High Oil Mist Alarm the Detector can be reset if the Oil Mist Concentration has lowered below the Alarm level.**





The OMD with exhaust gas feedback into the engine crankcase is under normal conditions suitable for crankcase pressures of +500 / - 500mmWC.

In case of missing or insufficient driving air supply the OMD is suitable for crankcase pressures of +500 / -500mmWC only if an optional pressure switch kit is applied.

Without optional pressure switch kit, the acceptable crankcase pressure is limited to +0 / -500mmWC.

The OMD with exhaust gas outlet towards the engine room is suitable for crankcase pressure range of +500mmWC / -100mmWC.



---

## **EC Declaration of Conformity**

---

We, the manufacturer

**SCHALLER AUTOMATION**  
**Industrielle Automationstechnik GmbH & Co. KG**  
**Industriering 14**  
**D-66440 Blieskastel**  
**Germany**  
**Tel.: 06842 / 508-0**  
**Fax: 06842 / 508-260**

declare on our own responsibility, that the product:

Kind of equipment: **Oil Mist Detector**

Type-designation: **VISATRON® VN115/87plus**  
**VISATRON® VN116/87plus**  
**VISATRON® VN215/87plus**

to which this declaration relates exclusively used for the detection and signaling of oil mist in diesel aggregates and complies with the following EG-directives

**Machinery directive 2006/42/EG**  
**EMC directive 2004/108/EC**

is in compliance with following standards:

**EN ISO 4414**  
**EN 60529**  
**EN 55022**  
**EN 61000-part 6-1 till 6-4**  
**EN ISO 12100**  
**CSPRI 16-1**  
**CSPRI 16-2**  
**CSPRI 16-4**  
**IACS UR M67**

**A technical documentation is completely available. The operating manual according to the oil mist detectors is available in the original version.**

D-66440 Blieskastel, 2012/08/02



Stephan Schaller  
- Managing Director -



**Table of Contents**

**1 Introduction and functional overview ..... 9**

**2 Installation instructions ..... 14**

**2.1 Mechanical installation ..... 14**

2.1.1 Basics ..... 14

2.1.2 Pipe dimensions ..... 18

2.1.3 Installation of pipe siphons ..... 19

2.1.4 Installation of the siphon block connection units ..... 21

2.1.5 Suction funnels in the crankcase compartment ..... 22

2.1.6 Pipe arrangement at valve box (VN215/87plus system only) ..... 23

2.1.7 Compressed air connection ..... 24

**2.2 Electrical installation ..... 25**

2.2.1 VISATRON® series VN87plus device ..... 25

2.2.2 Connection of monitoring devices ..... 28

2.2.3 Schematic electrical wiring diagram ..... 30

**3 Commissioning ..... 31**

**3.1 Adjusting or checking the suction pressure ..... 31**

**3.2 Filling of siphon blocks VN280plus of VN215/87plus system with oil ..... 32**

**3.3 Filling of siphon blocks VN180 for VN115/87plus and VN116/87plus system with oil ..... 34**

**3.4 Filling of pipe siphons for VN115/87plus and VN116/87plus system with oil ..... 35**

**3.5 Adjusting the sensitivity of the OMD ..... 36**

**3.6 Commissioning check list ..... 37**

**4 Operating instructions ..... 38**

**4.1 Display ..... 38**

**4.2 Reset of Oil Mist Alarms ..... 40**

**5 Troubleshooting ..... 41**

**5.1 Clean fresh air bores ..... 42**

**5.2 Clean infrared (IR-) filter ..... 42**

**5.3 Exchange air filters in the measuring head ..... 43**

**5.4 Exchange air filter in pressure regulator unit ..... 43**



<b>5.5</b>	<b>Exchange measuring head .....</b>	<b>44</b>
<b>5.6</b>	<b>Exchange bellows and suspension-system.....</b>	<b>46</b>
<b>5.7</b>	<b>Measuring head fuses .....</b>	<b>48</b>
<b>5.8</b>	<b>Check for earth fault problem .....</b>	<b>49</b>
<b>6</b>	<b>Maintenance procedures .....</b>	<b>51</b>
<b>7</b>	<b>Functional test .....</b>	<b>53</b>
<b>7.1</b>	<b>On board test.....</b>	<b>53</b>
<b>7.2</b>	<b>Factory test at engine builder with smoke generator on VN115/87plus and VN116/87plus installations.....</b>	<b>55</b>
<b>7.3</b>	<b>Additional pressure measurement on VN115/87plus and VN116/87plus installations .....</b>	<b>56</b>
<b>7.4</b>	<b>Factory test at engine builder with fog machine on all installations .....</b>	<b>58</b>
<b>8</b>	<b>Optional Spare Parts and Accessories .....</b>	<b>60</b>
<b>8.1</b>	<b>Service Kits.....</b>	<b>62</b>
8.1.1	Maintenance Kit .....	62
8.1.2	Cleaning Kit.....	63
8.1.3	Service Kit for VN115 .....	64
8.1.4	Service Kit for VN116 .....	66
8.1.5	Service Kit for VN215 .....	68
<b>8.2</b>	<b>Optional Service Box.....</b>	<b>70</b>
<b>8.3</b>	<b>Optional Commissioning Box .....</b>	<b>75</b>
<b>8.4</b>	<b>Optional Driving Air Conditioning (Part No. 272213) .....</b>	<b>77</b>
<b>9</b>	<b>Technical data .....</b>	<b>78</b>
<b>10</b>	<b>Service Partners .....</b>	<b>83</b>





## **1 Introduction and functional overview**

The newly developed VISATRON® series VN87plus Oil Mist Detector (OMD) from SCHALLER AUTOMATION protects large diesel engines against oil mist explosion, caused by spontaneously occurring oil mist. It is part of a safety system that secures the life and health of the operating staff and prevents heavy damages to the engine.

SCHALLER AUTOMATION developed this device to meet the IACS UR M10.

It is not possible to directly monitor all potential sources of oil mist inside a large diesel engine. There are main bearings, large end bearings, pistons, liners, sliders, pumps, camshaft bearings, chains, gears or even tools left behind from installation – all of these parts could produce oil mist e.g. in case of lubrication problems. Therefore the philosophy of SCHALLER AUTOMATION is that only OMD-systems can securely prevent oil mist explosions by detecting the primary origin of danger: the oil mist itself.

The VISATRON® series VN87plus OMD-System uses the approved wear-free suction system to continuously extract the atmosphere of the crankcase compartments and other engine locations. The system works actively and is not simply waiting for oil mist clouds. This ensures proper reaction times from the beginning of oil mist generation to an oil mist alarm.

To avoid false alarms, caused by splash oil, the suction system makes use of Schaller's special suction funnels working independent of the rotation sense of the engine. Additional draining components ensure correct working under all operating conditions. This includes the application in power plants as well as on vessels with their static or dynamic inclinations. False alarms initiated by condensing water vapour are prevented by an integrated heater inside the measuring head housing.

The OMD-System consists of following parts:

- VISATRON® series VN87plus oil mist detector
- Protection cover
- Suction system including pressure regulator
- Monitoring device (optional)

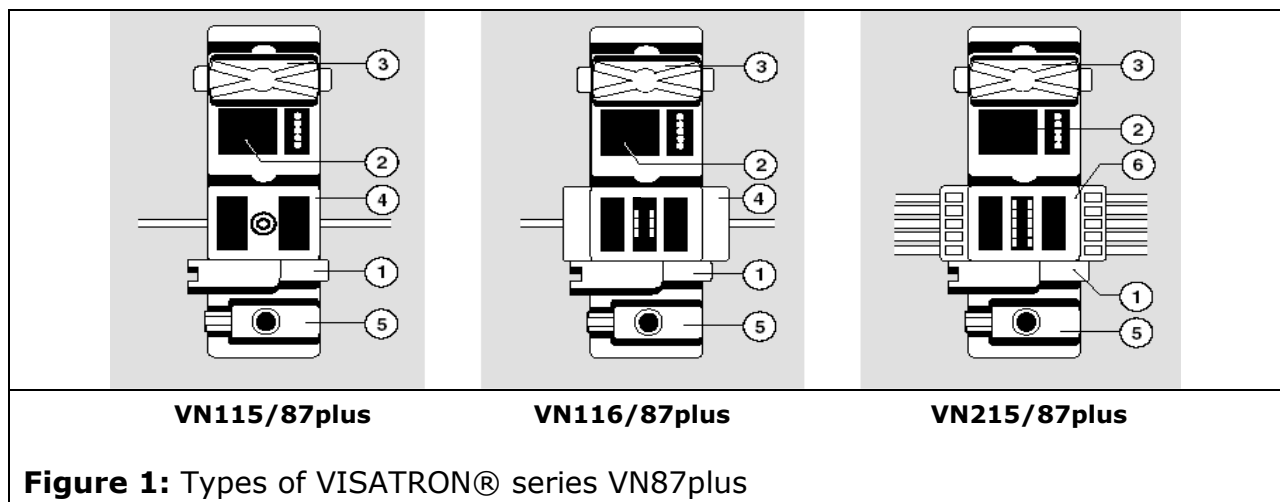
Three different types of the VISATRON® series VN87plus oil mist detectors are available (see Figure 1):

- VN115/87plus
- VN116/87plus
- VN215/87plus

All devices have a measuring head (2) which includes the optical measuring track under the control cover (3) and a display to give the user all important information for normal operations conditions. The measuring head is mounted on a vibration protected base plate.



A continuous supply of electrical current and air pressure is required for the system to operate. The negative pressure for the suction system is generated by an air jet pump (1) working with the Venturi principle. The electrical interface is integrated within a socket housing (5). The mating plug contains the Oil-Mist-Alarm button. The device can be connected directly to the engine safety system. The interface includes two Oil-Mist-Alarm outputs, a Pre-Alarm output and a Ready signal.



**Figure 1:** Types of VISATRON® series VN87plus

VN115/87plus

The suction system is connected to the common "Connecting Box" (4). This type of oil mist detector is able to detect an oil mist development, without identifying the location of the oil mist source inside the engine.

VN116/87plus

The suction system is connected to the "Valve Box 116" (4). This type of oil mist detector is able to detect an oil mist development, indicating in the valve box window the left or right side of the detector with the highest oil mist concentration.

VN215/87plus

The suction system is connected to the "Valve Box 215" (6). This type of oil mist detector is able to detect an oil mist development, indicating in the valve box window the compartment with the highest oil mist concentration.

In normal operation mode all models sample the atmosphere of the engine at all suction points in parallel through the suction system to the measuring head. Upon detection of an oil mist alarm the models VN116 and VN215 start an additional search run to determine the location of the highest oil mist concentration. The reaction time to an alarm is totally independent of the search run.

All devices offer two alarm levels.

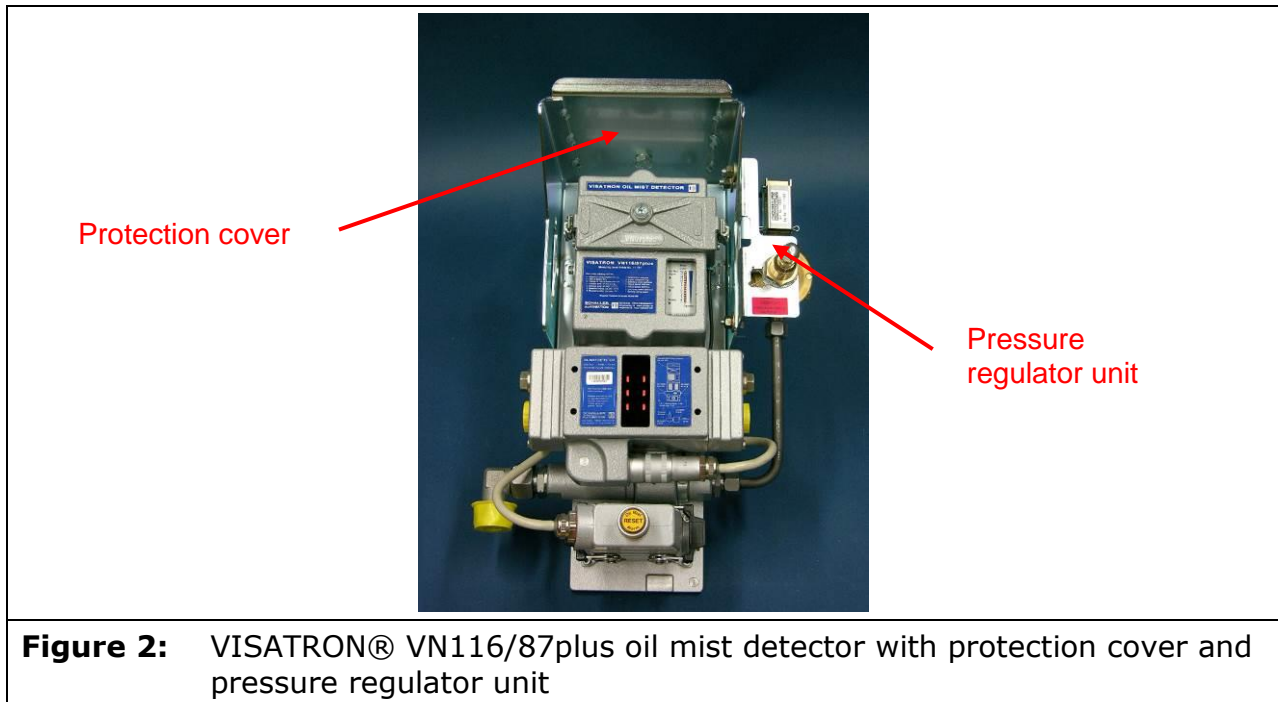
The Main-Alarm level can be adjusted with a switch at the rear side of the measuring head.

The Pre-Alarm will be activated at fix 70% of the Main-Alarm level.



To keep the optical track clean, all models use clean scavenging air in front of the filter glasses. This air is derived from the compressed air driving the air jet pump.

The devices can be ordered as single OMD device or integrated in a mounting unit. In this case the scope of supply includes an additional pressure regulator unit and a protection cover.



The suction system always requires a so called 'suction funnel' (see page 22, Fig. 18) at each suction point. This prevents the system against incoming splash oil. During normal operation mode of an engine the OMD sucks out a small concentration of oil mist which was generated by Blow-By or mechanical spraying. This oil mist may fall out in the suction pipes and must be drained out the pipes. Ideally, drainage flow back ends inside the engine's crankcase.



The best method on a VN115/87plus and VN116/87plus installation to drain the system is to use pipe siphons. Also recommended is the use of siphon blocks.

On 2-stroke engines the crankcase and the combustion chambers are separated by stuffing boxes, which let the crankcase be nearly free of Blow-By. Therefore it's also possible to use the suction funnel as draining device. In this case it is necessary to mount the suction pipes with an inclination of greater than 6°.

To become independent from fast changes of the engine room air pressure, it is recommended that the output of the air jet pump is blown back into the crankcase. If the air is blown into the engine room, SCHALLER AUTOMATION offers an optional oil separator which should be mounted directly to the output of the pump.



**Figure 4:** Optional Oil separator for air outlet

*Remote monitoring devices:*

The OMD device can be connected to Schaller's monitoring devices Remote Indicator II to monitor the oil mist concentration and the status of the OMD device from a safe location as requested by IACS UR M10. The connection to the monitoring devices is realized by a RS485 two-wire bus.



**Figure 5:** Optional Remote Indicator II


Additionally Schaller realized an integration of the VISATRON® devices into ship automation systems (e.g. Mega-Guard of Praxis Automation).

Thus, the series VN87plus is a further contribution to safety at sea. Our goal is to avert damage to assets, personnel and the environment.



**Important features of the series VN87plus compared to the series VN87**

- Heater is integrated into the measuring head, no external connector
- Scavenging air is integrated into the measuring head, connecting hose same as supplied before
- Pre-alarm interface available, threshold is fixed to 70% of main-alarm level
- Serial interface for monitoring devices is integrated
- Additional error codes
- Switch for the adjustment of the main-alarm level is placed on the rear side of the measuring head, no disassembly of the electronic module furthermore necessary
- Switch for the adjustment of the bus device address is available on the rear side
- Easier access to the wire break resistors on the rear side
- Optional 4 -20 mA output of the relative opacity data

	<p><b>And finally very important</b>                  No changes of the base plate mechanical interface (or the measuring head) compared to the series VN87. So, base plate of VN115/87 is interchangeable with VN115/87plus, VN215 with VN215/87plus, etc.</p>
---	---



## 2 Installation instructions

### 2.1 Mechanical installation

#### 2.1.1 Basics

There are multiple potential sources of oil mist inside an engine. These are for example defective main bearings, connecting rod bearings as well as piston seizures, chains and covers of pumps. For each of these individual sources you could determine the "optimum" suction point. The result would be a vast number of holes to be distributed over the entire engine. To find out a safe and economic solution to monitor oil mist SCHALLER AUTOMATION recommends the OMDEA-test (Oil Mist Detection Efficiency Approval). In each case the following rules are recommended.



**CAUTION!** Do not ignore the warnings. The safety of persons can be endangered

Following rules are recommended by SCHALLER AUTOMATION:

- Use at least one suction point per compartment.
- Use always the long version of the suction funnels. This makes the installation independent from the rotation sense of the engine.
- At least one suction point per chain drive or gear drive is necessary.
- Avoid the splash oil disk of the crankshaft bearings.
- Select points in the upper area of the crankcase, as oil mist tends to rise upwards!
- The detection unit has to be placed above the suction points.
- Installation Rules: in general avoid U-bends or kinks in the tubing system.
  - VN115/116 with pipe siphons: Mount one pipe siphon at each end of the horizontal header pipes, place the pipes a little bit above the suction points and connect the pipes and the engine wall connections with flexible tubes.
  - VN115/116 with siphon blocks: Use one siphon block at each compartment.
  - VN215 with siphon block: Use one siphon per compartment. If a suction point is placed above the detection unit e.g. at the camshaft use a pipe siphon at the lowest point of the pipe to avoid an oil pocket, which could clog the pipe.
  - VN215 without draining components: The pipes have to be mounted with an angle greater than 6° inclination.

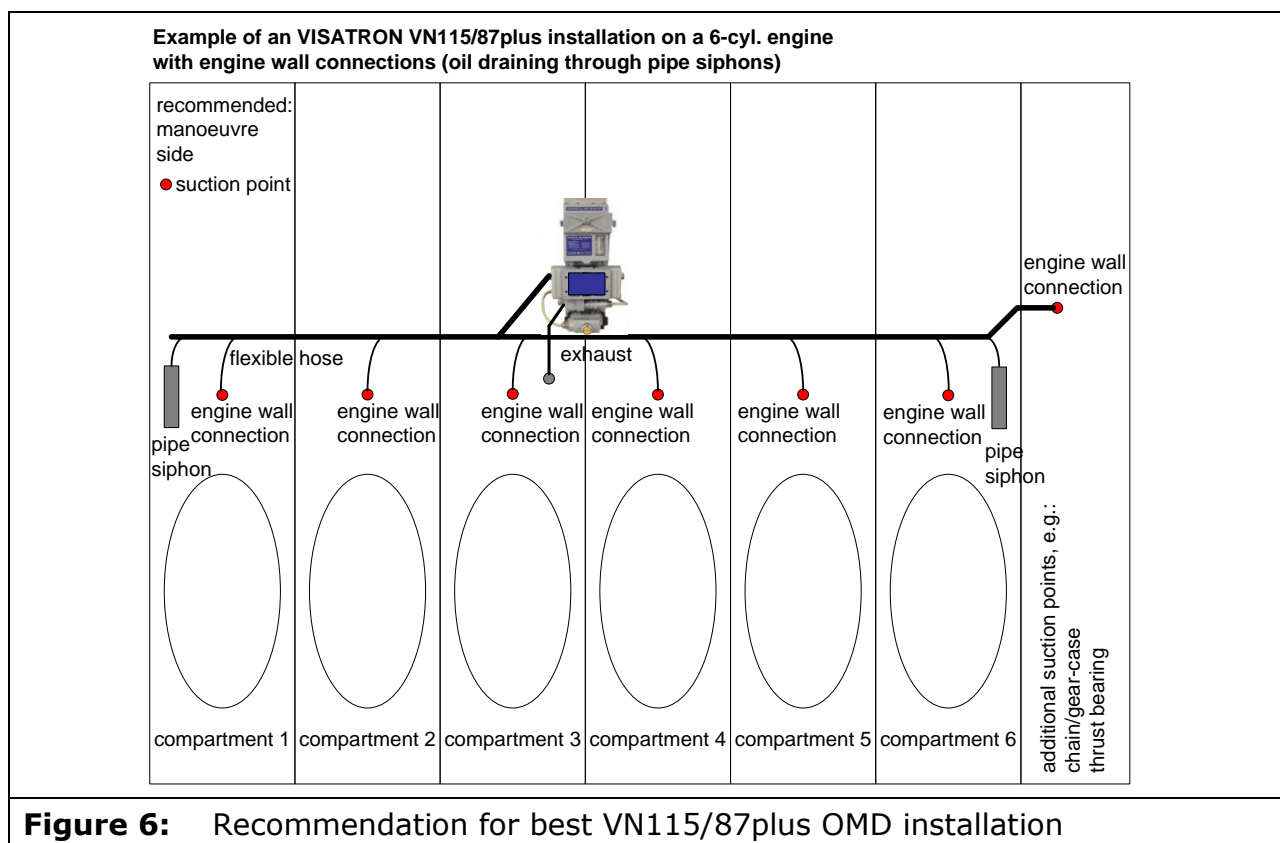


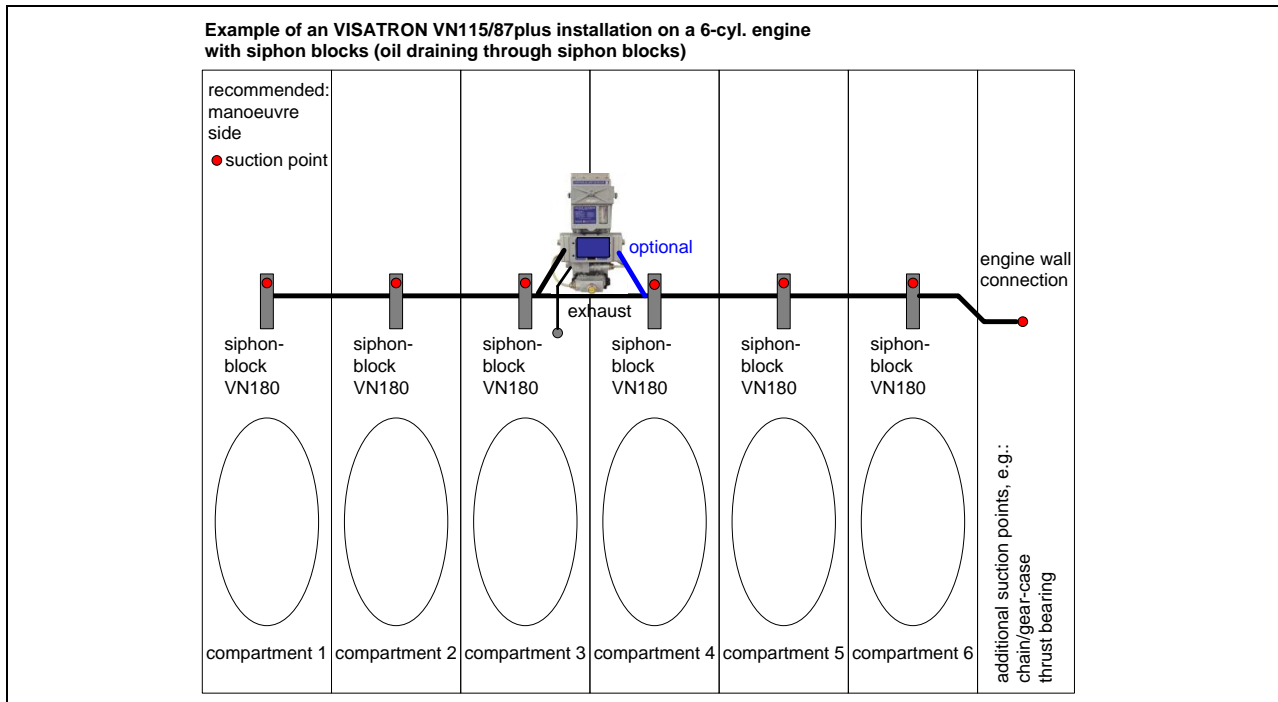
- If possible mount the device on the engine side opposite to the crankcase relief valves, to reduce danger to the crew during a damage situation.
- If possible place the VISATRON® detection unit in the center of the engine to avoid long pipe runs.
- Select only suction points which allow the use of long suction funnels. In this case the installation side is independent from the rotation sense of the engine. Installations without any suction funnels are not allowed.
- If recommended by engine builder, determine an additional suction point at the camshaft bed.

**SCHALLER AUTOMATION recommends a final test procedure per engine type called OMDEA (Oil Mist Detection Efficiency Approval).**

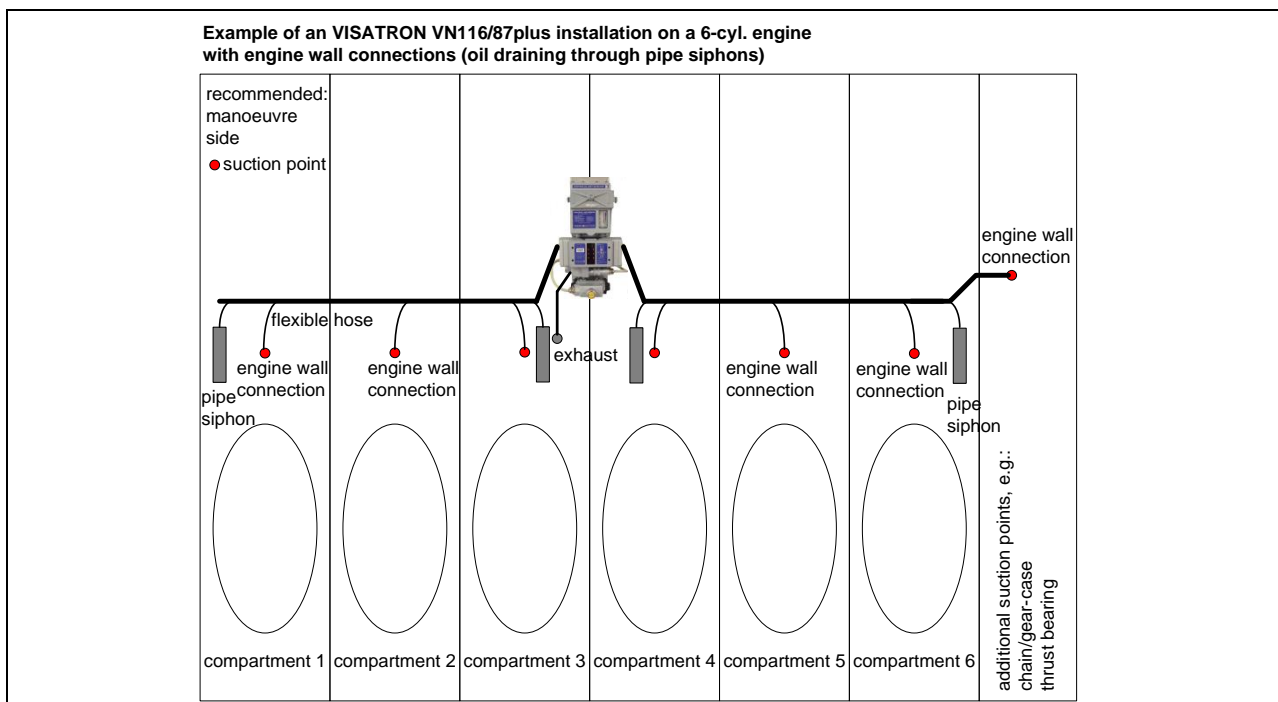
According to the IACS unified requirement M10 the installation drawings have to be approved from engine builder and SCHALLER AUTOMATION. The installations have to be executed in compliance with these drawings and the contents of this manual.

The following figures show typical installation arrangement on a 6 cylinder engine.





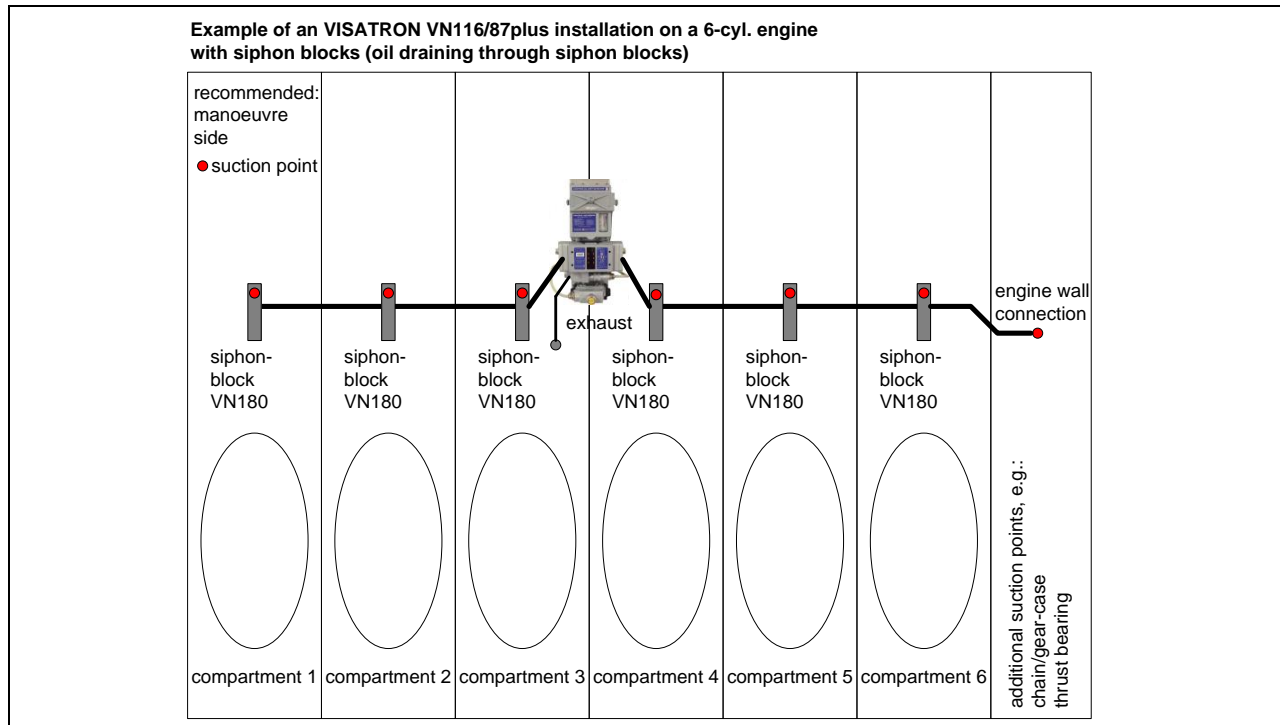
**Figure 7:** Alternative installation of VN115/87plus OMD



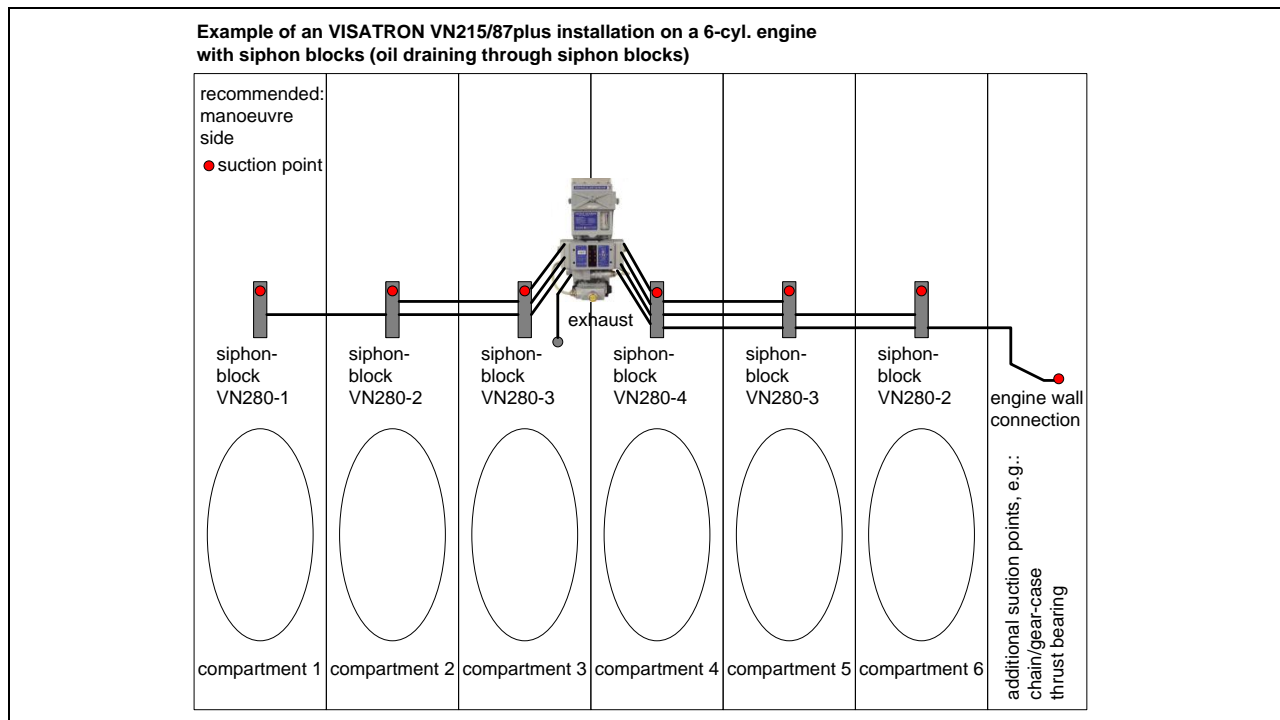
**Figure 8:** Recommendation for best VN116/87plus OMD installation





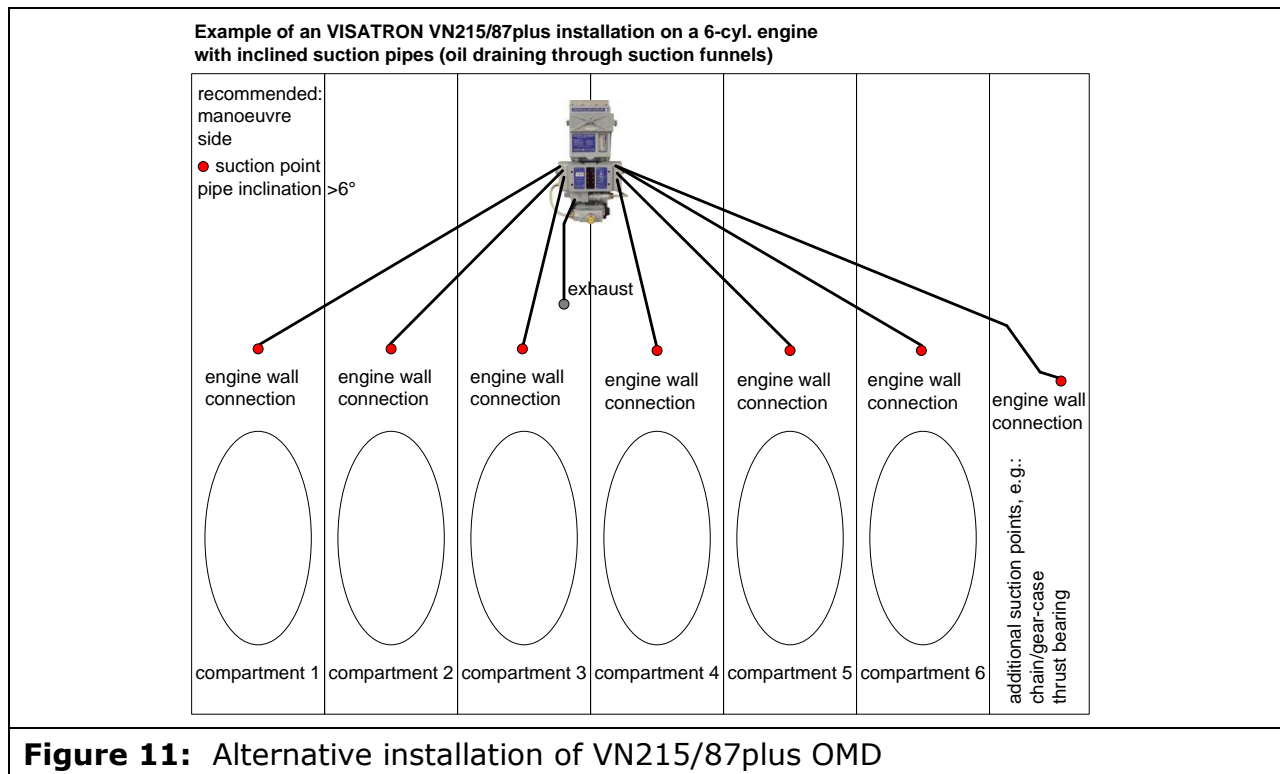


**Figure 9:** Alternative installation of VN116/87plus OMD



**Figure 10:** Recommendation for best VN215/87plus OMD installation





### 2.1.2 Pipe dimensions

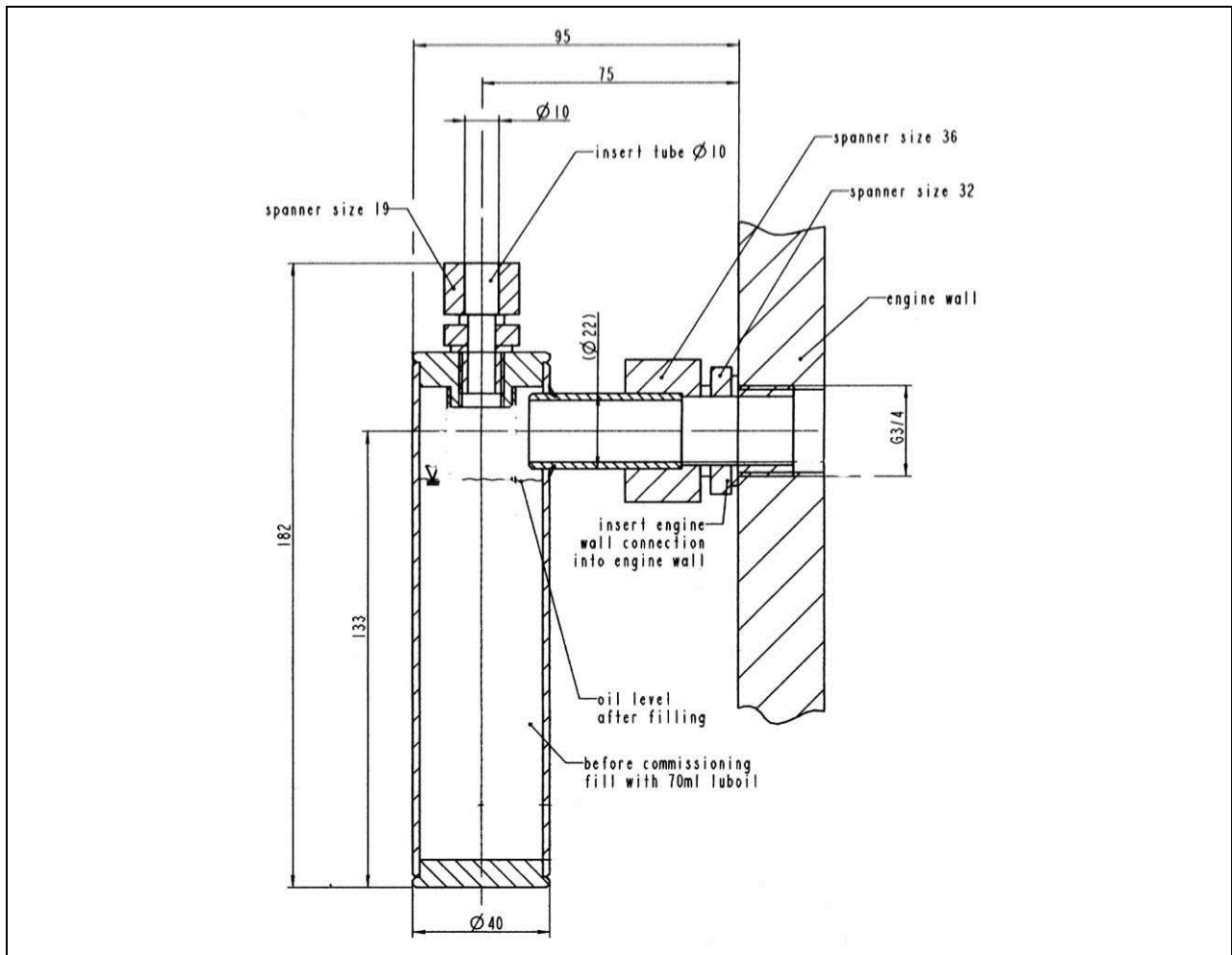
- For VN115 and VN116 standard applications:
  - Seamless steel pipes: 22 mm outer diameter, 2 mm wall thickness
  - Flexible hoses: inner diameter not less than 6 mm
  
- For VN215 standard applications:
  - Seamless steel Pipes: 14 mm outer diameter, 2 mm wall thickness or, if 14 mm is not available
  - Seamless steel Pipes: 13,71 mm (known as 1/4-inch pipes, schedule no. 40, 0.540 inch outer diameter, 0.088 inch wall thickness)

The length of exhaust air pipe (outlet of the venturi injector) should be limited to max. 4m. If a longer tube is required, please contact Schaller Automation. The inner diameter has to be  $\geq 18$  mm. U-bends and kinks are forbidden.

All installation solutions must have written agreements by SCHALLER AUTOMATION as required by IACS UR M10.



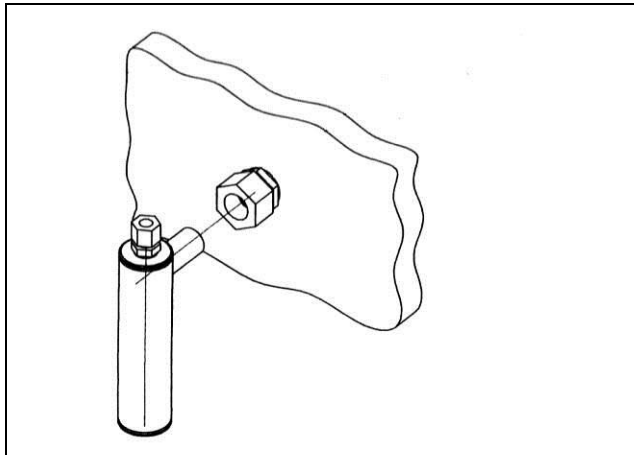
### 2.1.3 Installation of pipe siphons



**Figure 12:** Pipe siphon

- Mount the engine wall connection into the G3/4" thread with 110 Nm torque
- Put the pipe siphon in the hole
- Fix the clamping nut
- Fill the pipe siphon with oil (see chapter 'commissioning')
- Fix the flexible tube on the top fitting

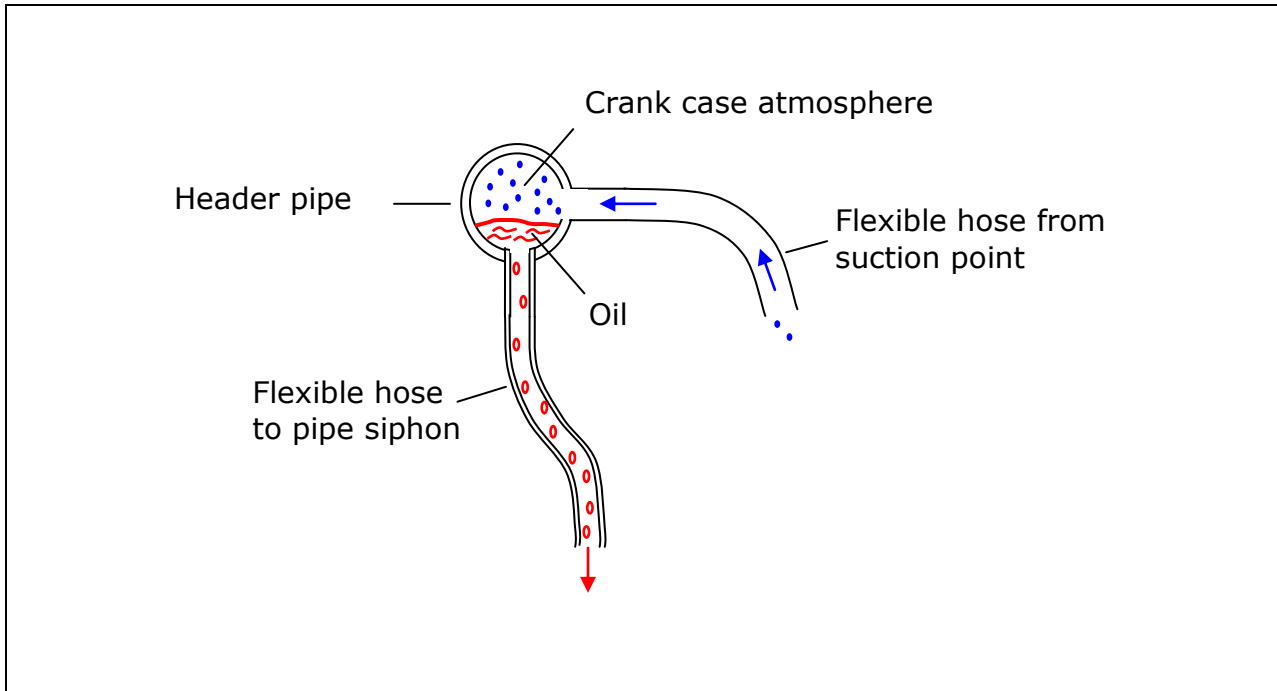




**Figure 13:** Pipe siphon at engine wall



**Figure 14:** Image of pipe siphon



**Figure 15:** Oil draining principle



2.1.4 Installation of the siphon block connection units

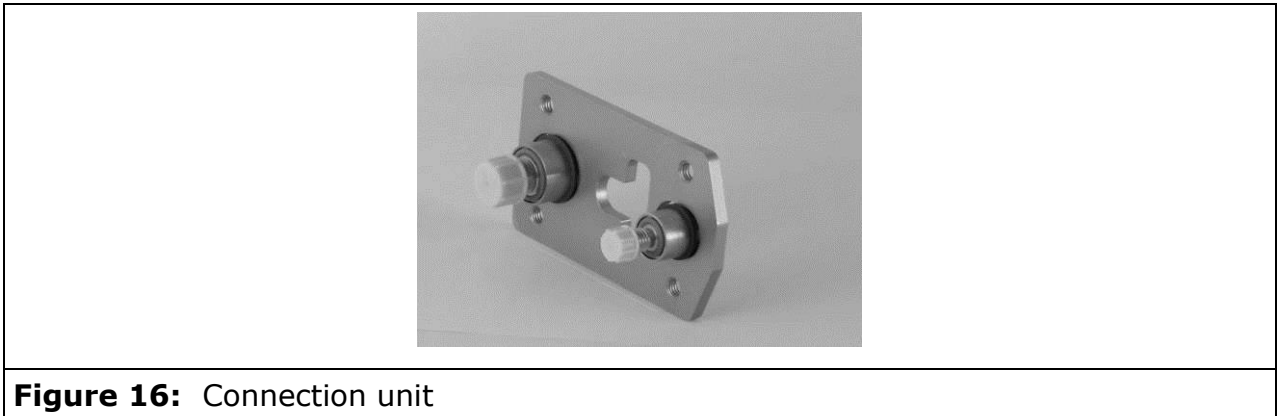


Figure 16: Connection unit

Consider the following points:

- Take note of the drilling template (made of paper, included with the connection units)
- Drill through
- Seal all threads with 'Loctite 572'
- Max. torque = 30 Nm

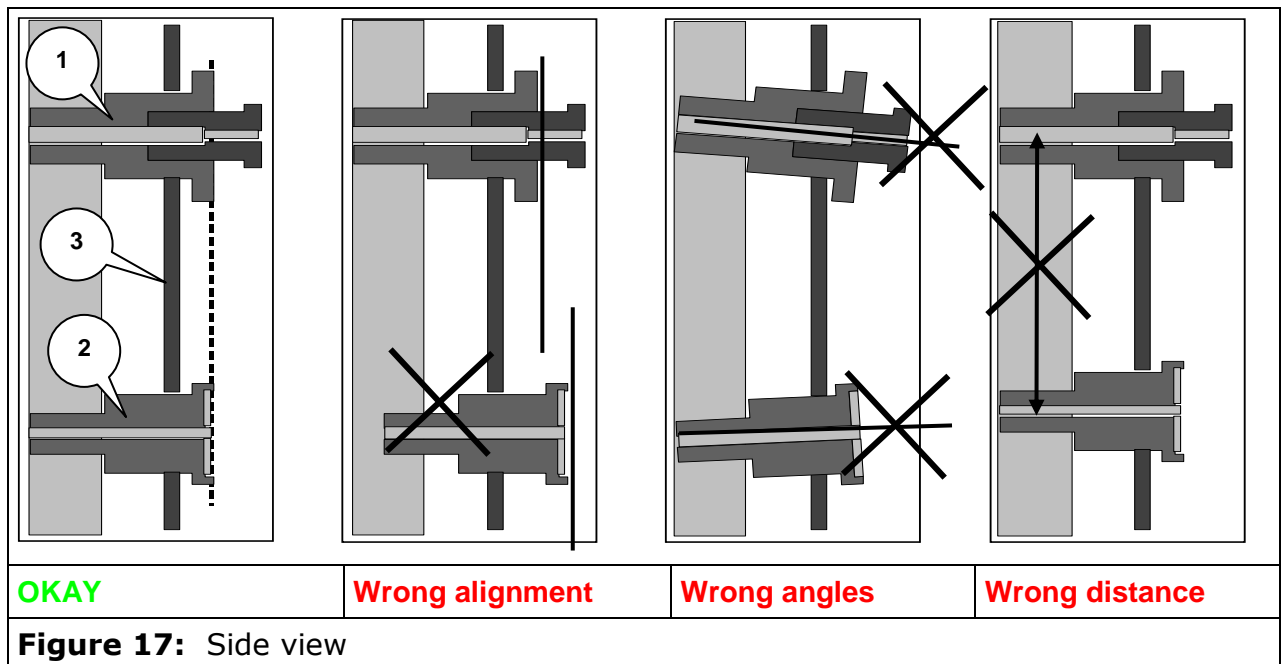


Figure 17: Side view

- Avoid wrong alignment, wrong angles and incorrect distances (see Figure 17)
- Insert the suction funnel from the crankcase side into the siphon block, align it in a vertical position (see Figure 18) **with the opening at the bottom** and fix the small clamping nut.

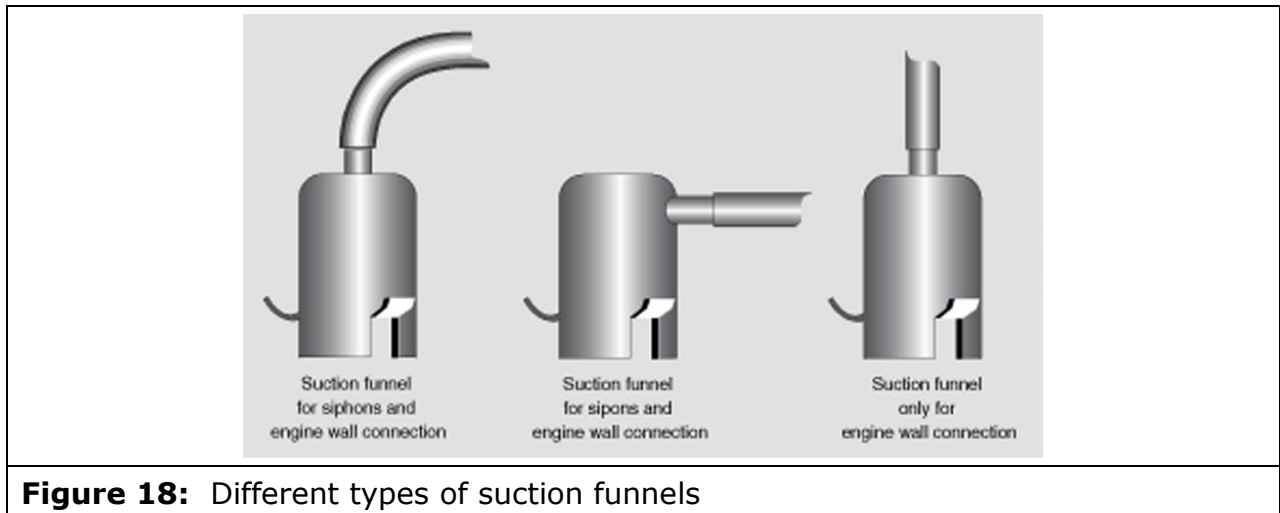


### 2.1.5 Suction funnels in the crankcase compartment

The suction funnels have to be fitted in such a way that flooding by splashing bearing oil or returning piston cooling oil is avoided (see Figure 18).



**CAUTION!** Make sure funnels do not interfere with rotating or moving parts of the engine.



2.1.6 Pipe arrangement at valve box (VN215/87plus system only)

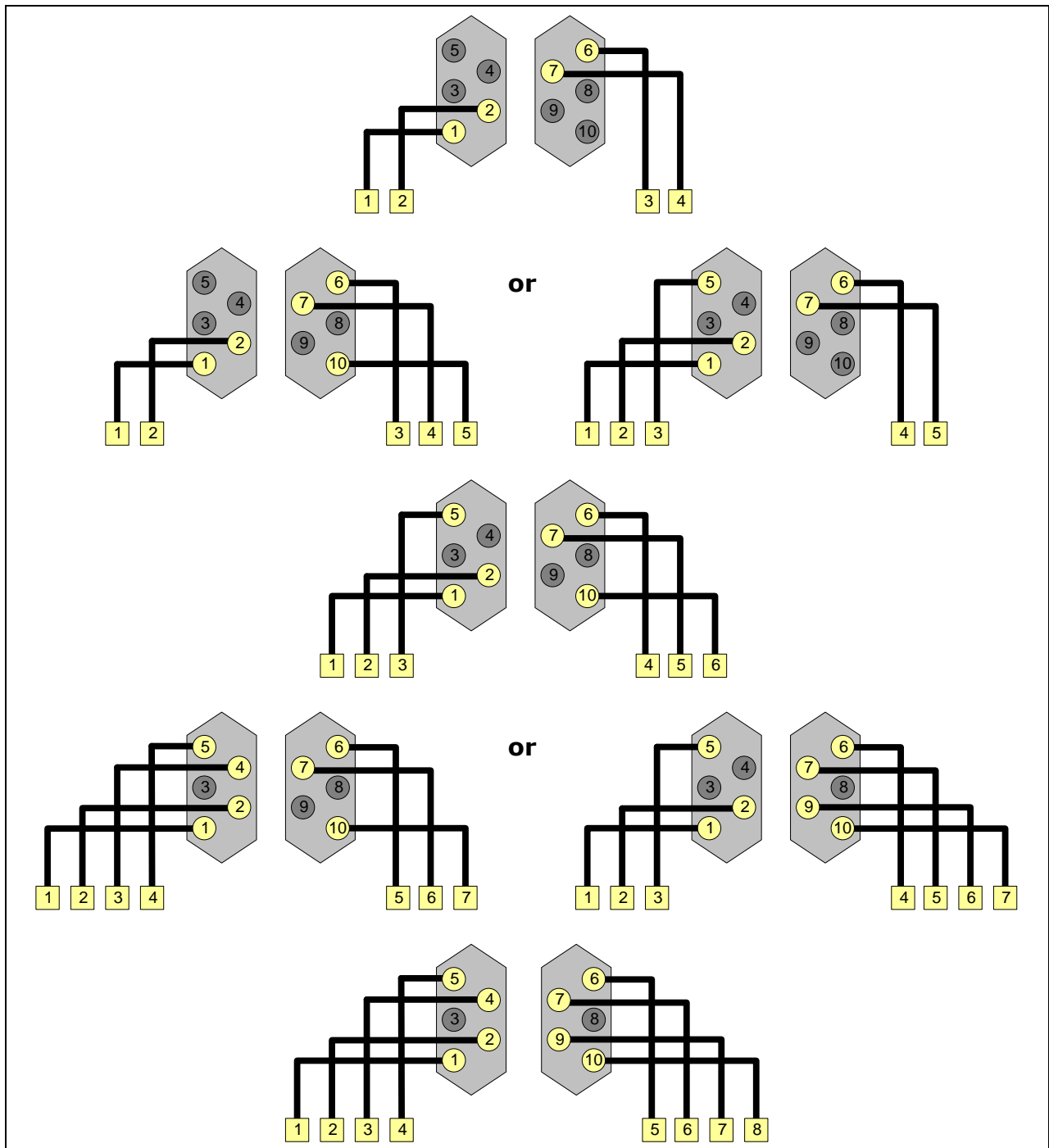
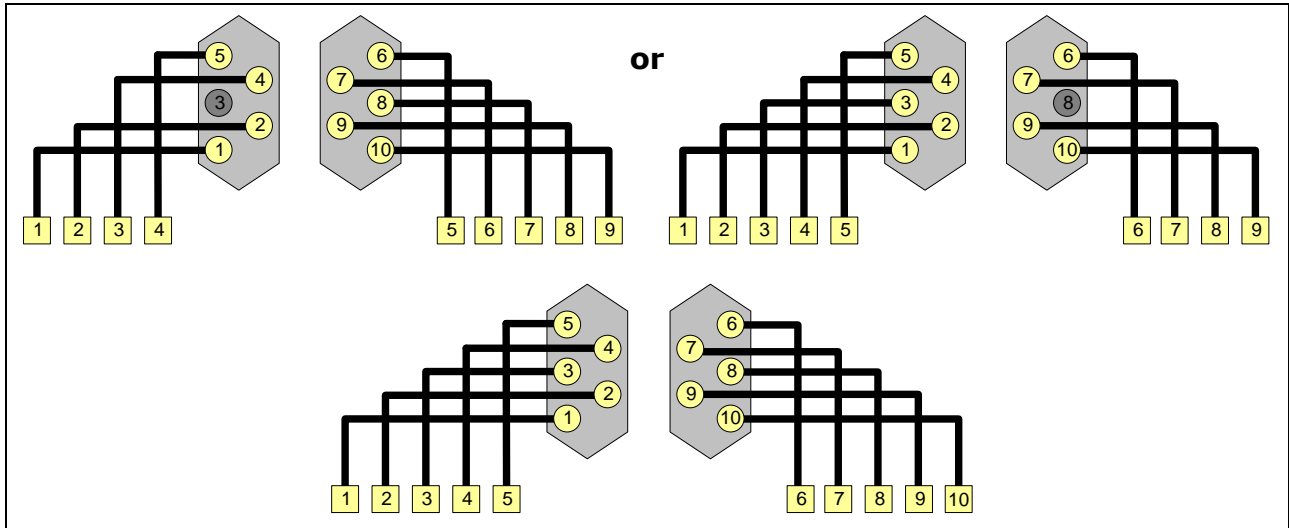


Figure 19: Pipe arrangement for 4 to 8 suction points





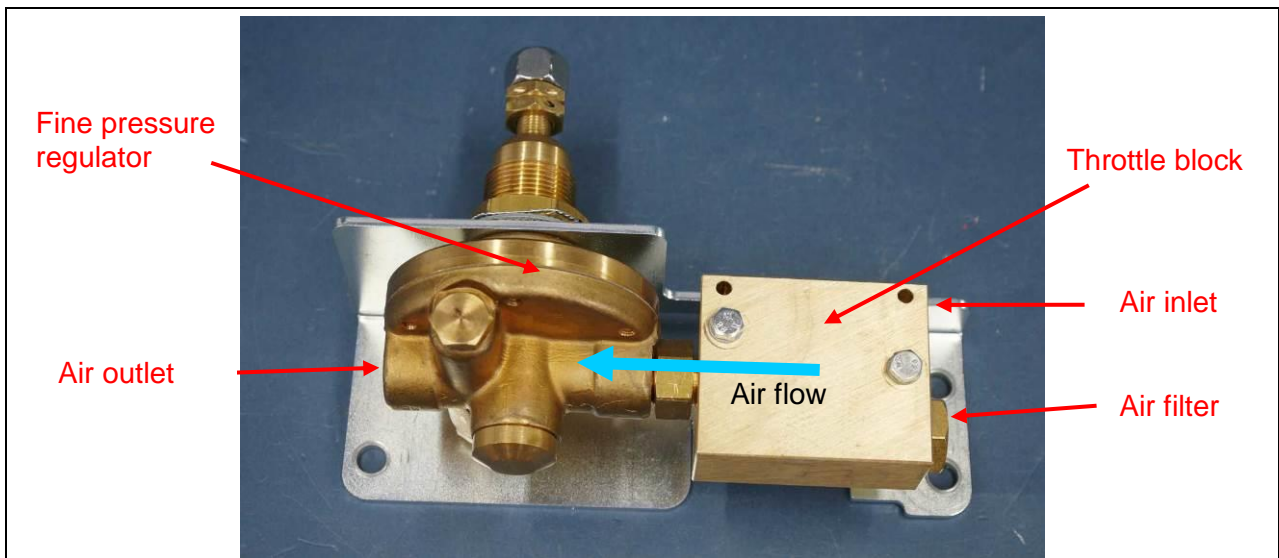
**Figure 20:** Pipe arrangement for 9 and 10 suction points



**CAUTION!** Other arrangements are not valid. Unused connection points (see Figure 19 and Figure 20, marked dark grey) must be closed by supplied rubber plugs. If not respected, malfunction of the OMD-System may occur!

### 2.1.7 Compressed air connection

If the SAB pressure regulator (see Figure 21) is used, connect the compressed air supply at the NTP/BSP/G1/4A fitting. Do always connect OMD to engine's control air system, pressure range 2 - 15bar. A **dry and clean air (ISO8573-1:2010 – 6-4-4)** with low humidity/oil contamination is of high importance.



**Figure 21:** Pressure regulator unit

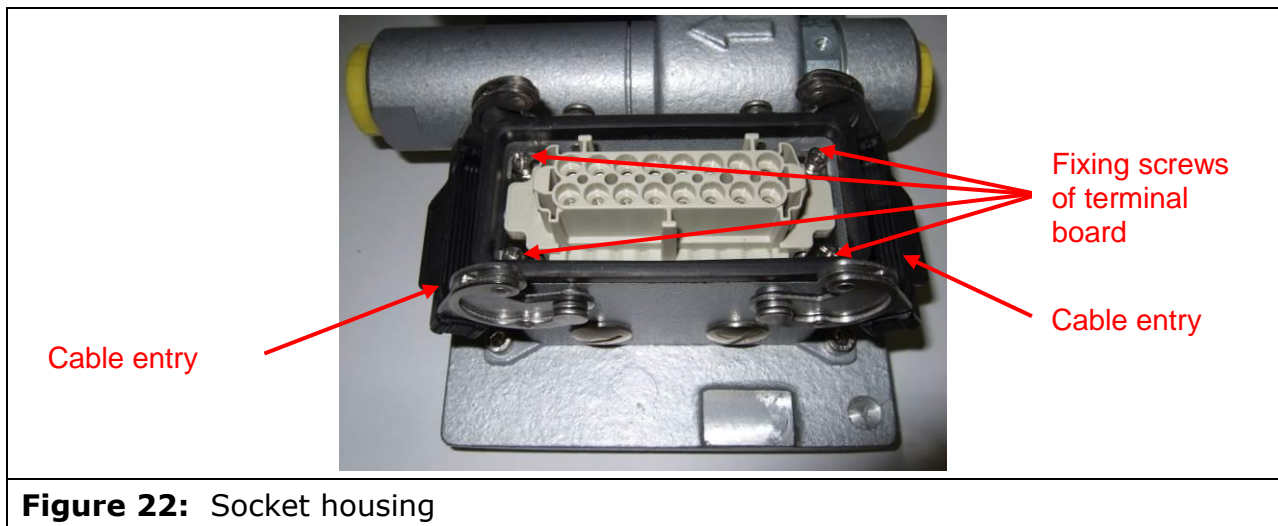




## 2.2 Electrical installation

### 2.2.1 VISATRON® series VN87plus device

The electrical terminal is inside the socket housing (see Figure 22) on the base plate of the VISATRON® device. The pin assignment is specified in Figure 25. The cable entry points are located on either side.



**Figure 22:** Socket housing

According to the pin assignment of Figure 25 connect the VISATRON® device to the 24 Volts power supply. The supply voltage can be potential free or not. The earth connection between the OMD and the engine is carried out by the fixings screw of the base plate or protection cover.

Additionally connect one alarm relay output to the safety system of the engine. As specified by the classification societies the 'Alarm' relay must be connected either to the shutdown or to the slow-down input.

During normal operation the alarm relay is switched off. In case of an oil mist alarm the relay is switched on. To monitor this output, a wire break resistor is installed (between pin 7 and 8 and between 15 and 16 as shown in Figure 25).

To replace the wire break resistors the measuring head has to be dismantled. The resistors (see Figure 24) are located on the rear side under the plastic cover (see Figure 23). The plastic cover can be removed via the screws. Do not forget to write the resistor value on the plastic cover with a permanent marker.

Also placed on the rear side two jumpers are available to select the interface mode: RS485 bus or 4- 20mA output of the relative opacity at pin 11 and 13.



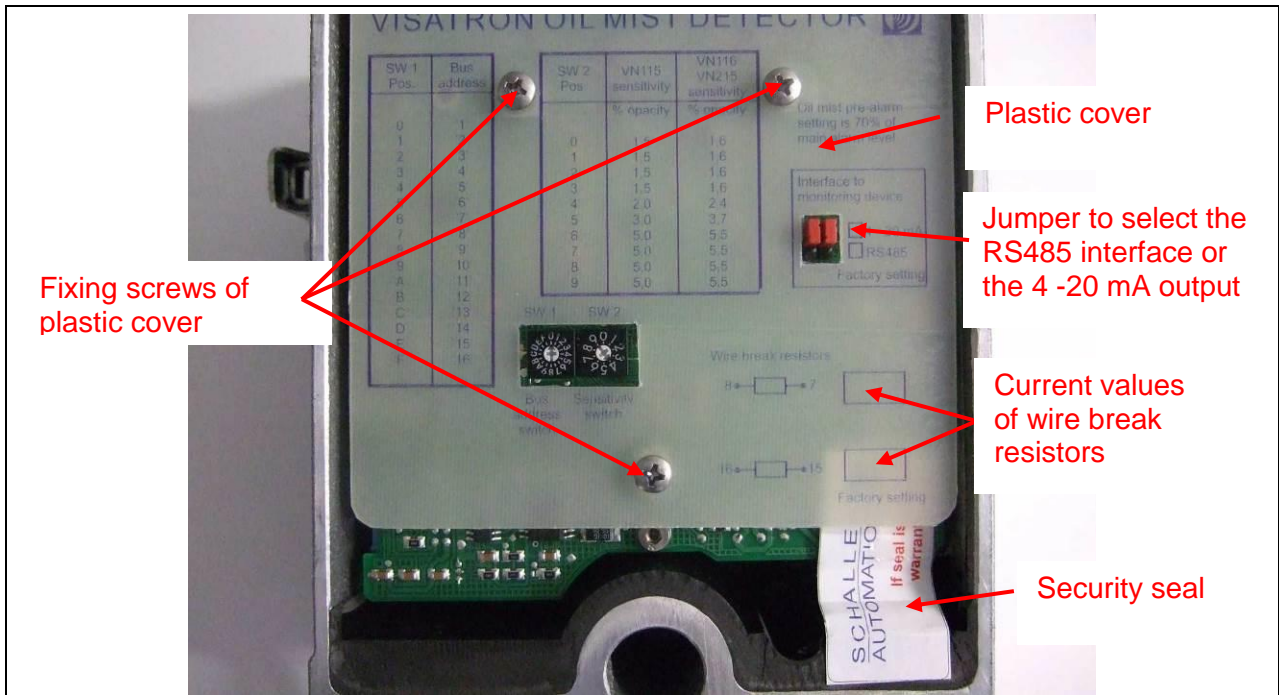


Figure 23: Rear side of measuring head

Second 'Alarm' output and 'Ready' output must be connected to separate channels on vessel's or power plant's alarm monitoring system. The 'Ready' relay is switched on when OMD is in correct operation (see Figure 25).

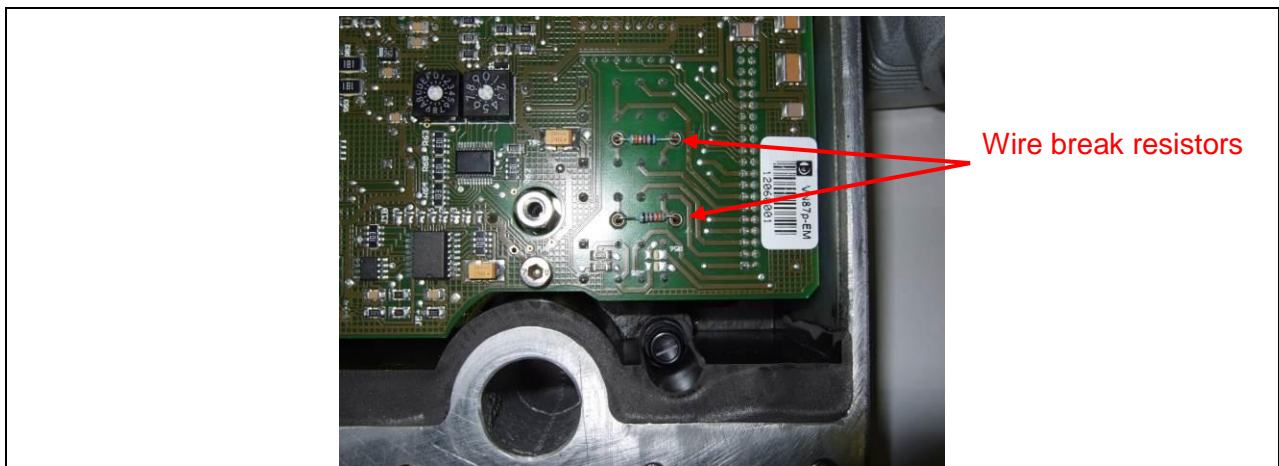


Figure 24: Wire break resistors

The optional pre-alarm output can be used to initiate either a pre-warning signal or slow-down signal. The pre-alarm relay is switched on when the oil mist concentration has risen up to 70% of the Oil Mist alarm level. Please note that depending on the characteristics of an oil mist occurrence, the time between 'Pre-alarm' and 'Main Alarm' could be only a fraction of a second.



Shown is non-operated relay condition

Description	Pin		Description
24 Volts DC +	1	9	'Pre-alarm' relay
24 Volts DC GND	2	10	'Pre-alarm' relay
'Ready' relay closed	3	11	RS485 B (opt. 4 - 20 mA -)
'Ready' relay open	4	12	Reserved, do not use
'Ready' relay common	5	13	RS485 A (opt. 4 - 20 mA +)
'Alarm' 1 relay closed	6	14	'Alarm' 2 relay closed
'Alarm' 1 relay open	7	15	'Alarm' 2 relay open
'Alarm' 1 relay common	8	16	'Alarm' 2 relay common

**Figure 25:** Pin assignment

- We recommend connecting 'Alarm' 1 to the alarm system and 'Alarm' 2 to the safety system.
- Alarms 1 and 2 are getting switched simultaneously by same relay.
- The relay outputs are potential-free.
- In case of a High Oil Mist Alarm, contacts 7 and 8 as well as 15 and 16 are closing
- In case detector goes into 'READY'-Mode, contacts 4 and 5 are closing
- In case Pre-Alarm is activated, contacts 9 and 10 are opening. Pre-Alarm will be switched as soon as 70% of High Oil Mist Alarm level is reached.

Power supply	18 – 31.2 Volts DC, max. 2 A
Nominal voltage	24 Volts DC
Relay Outputs	Max. 60 Volts DC, 1 A
Internal fuse	2 A semi time lag

**Table 1:** Electrical specification

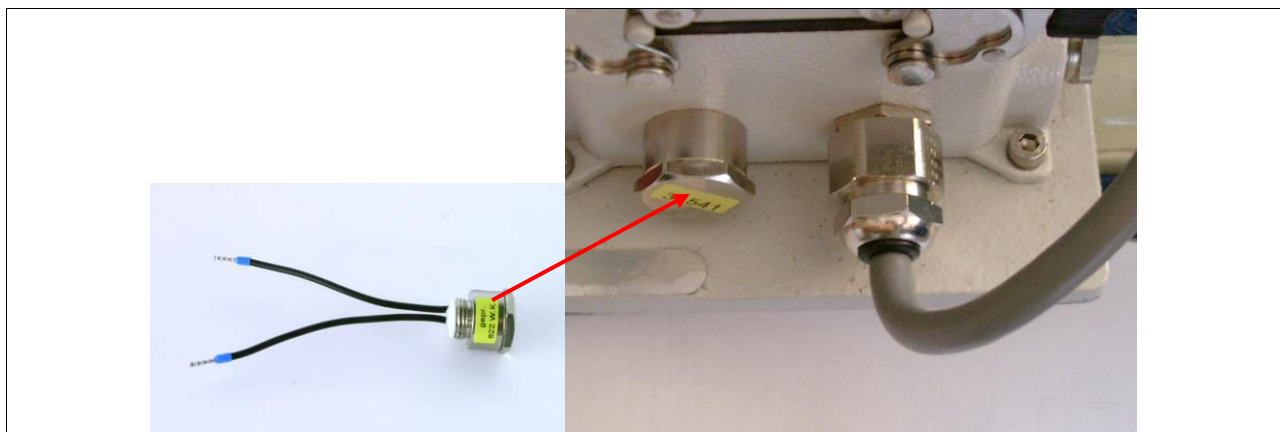


### 2.2.2 Connection of monitoring devices

As required by IACS UR M10 the OMD device can be connected to Schaller's remote monitoring devices Remote Indicator II to monitor the oil mist concentration and the OMD status from a safe location.


The connection to the monitoring devices is accomplished via a RS485 two-wire bus. In case of a Remote Indicator II the connection is only a two point link. The bus system at the OMD device must be terminated by the resistor. It is integrated in the terminator (see Figure 26+Figure 27), which is supplied with the monitoring device.

The used communication cable must be twisted pair and shielded. We recommend LAPPKABEL UNITRONIC-FD CP (TP) plus UL-CSA, AWG20. The total bus length is limited to 400 m. The VISATRON® device cable entry (see Figure 26) at the VISATRON® device is designed for cable diameter between 7.5 and 10.0 mm.

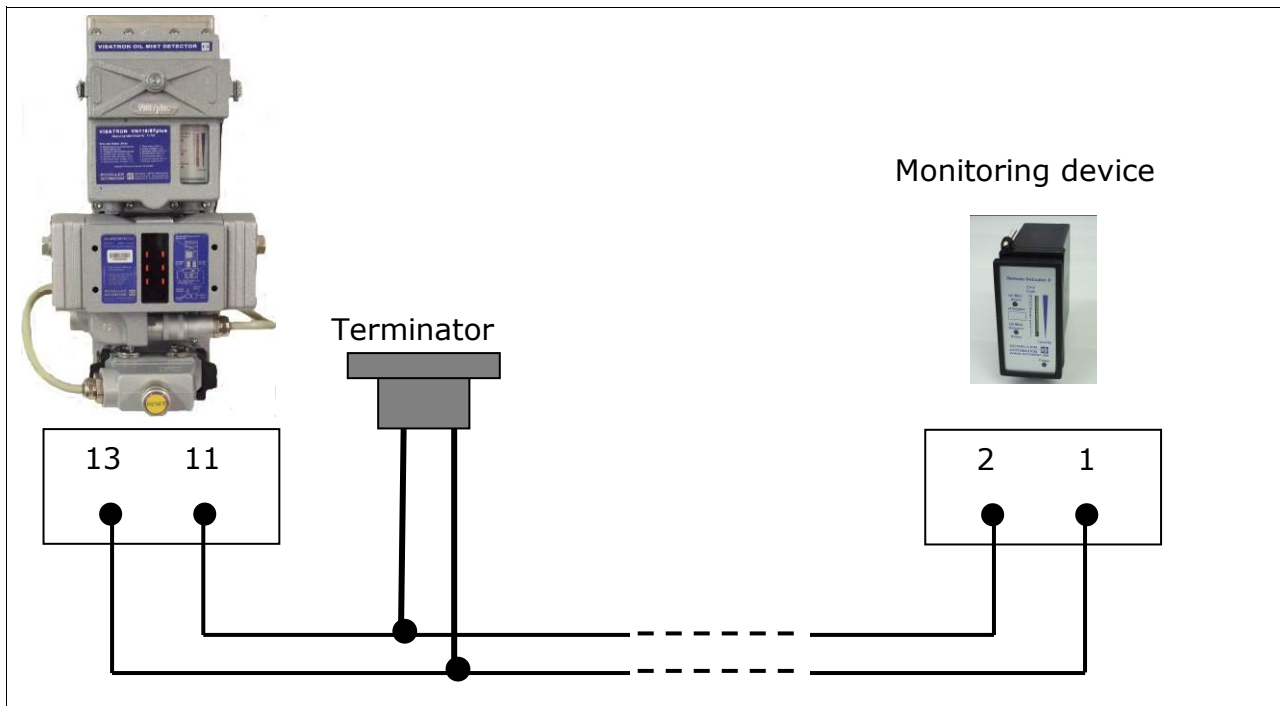


**Figure 26:** Cable entry and bus-terminator on the bottom side of the VISATRON® device

The connection between the OMD device and the monitoring device for standard applications is shown in the following wiring diagram (see Figure 27)

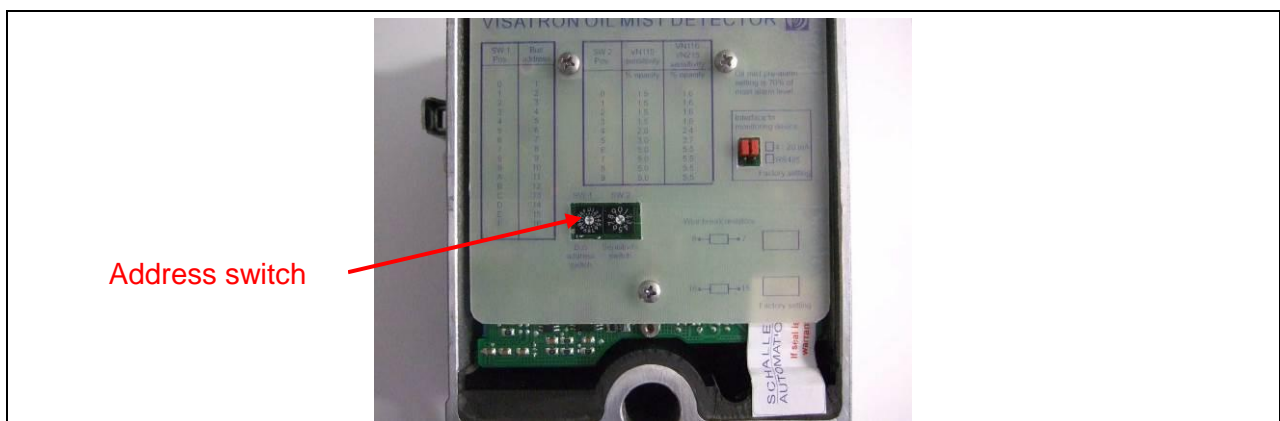
	<p><b>WARNING!</b> The shield must be connected directly at the cable grommet.</p>
---	--





**Figure 27:** Wiring diagram to connect Remote Indicator II

The monitoring device is the bus master and the OMD devices are the slaves. It's necessary to adjust different bus addresses at each slave device. Normally the first OMD device gets the address '1' and so on. The switch is on the rear side of the measuring head (see Figure 28).

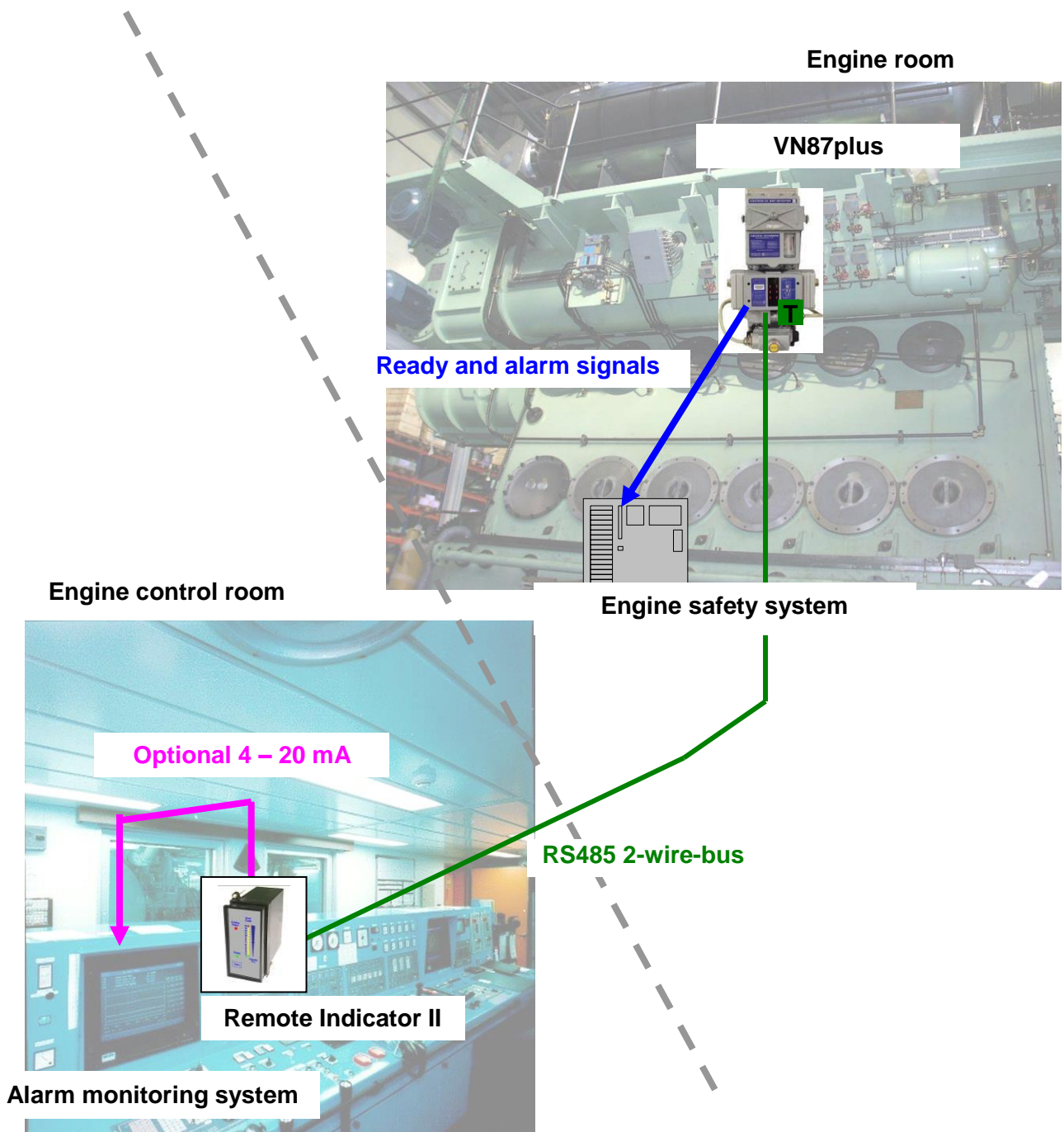


**Figure 28:** Bus address switch at the rear side of the measuring head





2.2.3 Schematic electrical wiring diagram

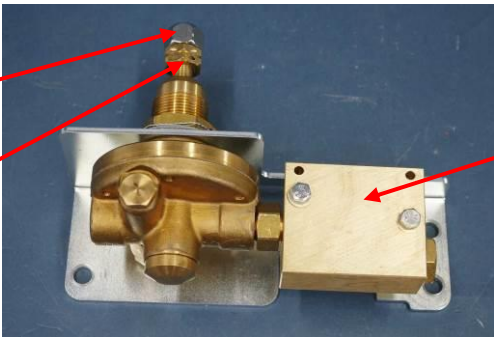



### 3 Commissioning


	<b>CAUTION! Unplug the OMD during welding processes on the engine.</b>
---	--

#### 3.1 Adjusting or checking the suction pressure

The suction pressure must be set by adjusting the pressure regulator when the engine is at standstill. Make sure ventilation of the engine room is in operation.

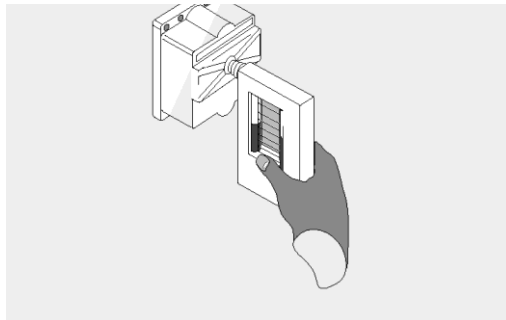
<p>Setscrew</p> <p>Counter-nut</p>		<p>No need to touch throttle-block for pressure setting. Pressure setting by setscrew on left side only!</p>
<p><b>Figure 29:</b> Pressure regulator unit</p>		

	<p><b>WARNING! Adjust 60 mm WC negative pressure.</b> After adjustment, remove U-tube pressure gauge and screw in the previously removed plug.</p>
---	--

	<p><b>CAUTION!</b> A pressure setting much higher than 60 mm WC negative pressure may cause a change in detecting sensitivity and can impact the functionality of the siphon blocks.</p>
---	--

- Connect a U-tube manometer at inspection cover (see Figure 30). (U-tube manometer is included in the service box, available as an option).
- Switch on compressed air supply with inlet pressure in a range from **2 to 15bar (before connecting the OMD the first time check the pressure).**
- If the negative suction pressure is already adjusted to 60 mm WC within a tolerance of  $\pm 5$  mm remove the U-tube manometer and finish the procedure.
- Otherwise loosen counter-nut.
- Turn setscrew until the negative pressure is only 60 mm WC.
- Tighten counter-nut.





**Figure 30:** U-tube manometer connected to OMD control cover

- Remove U-tube manometer

### 3.2 Filling of siphon blocks VN280plus of VN215/87plus system with oil

- Press the pump lever of the filling pump (see Figure 32) as many times until first oil drops come out.
- Unscrew the lower siphon block plug (see Figure 31).
- Insert filling pump nozzle.



**Figure 31:** Siphon block VN280plus for 5 connecting tubes (5 holes on its side)



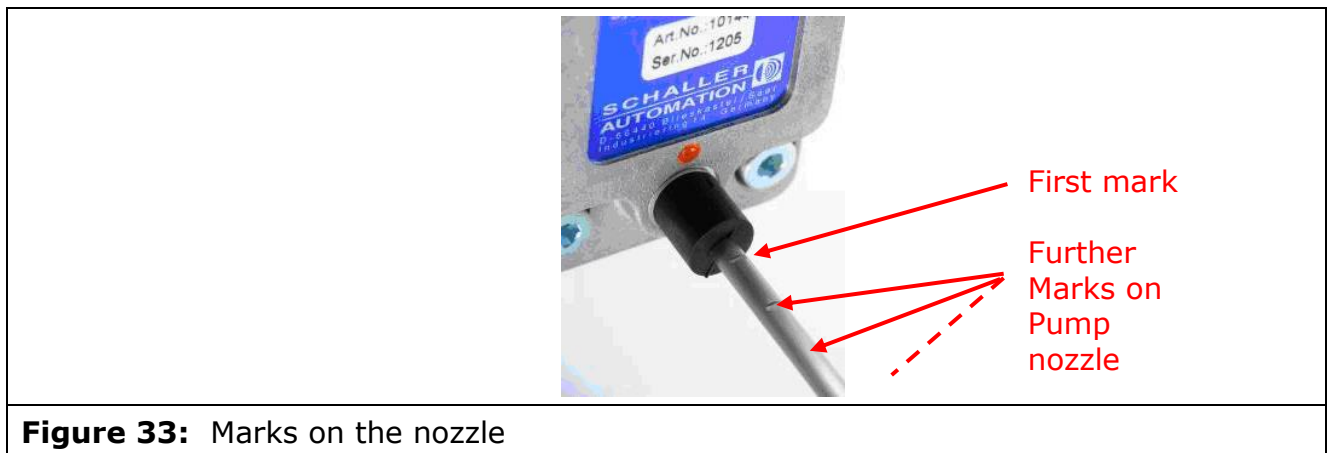
**Figure 32:** Filling pump

- Press the black nipple into the block's lower screw hole (see Figure 32).







- Pumps nozzle is equipped with 5 marks for max. 5-hole siphon block
- Push in the nozzle to the first mark next to the nozzle's tip (see Figure 33).



**Figure 33:** Marks on the nozzle

- Fill in 12 pump strokes, then push in the nozzle ca. 10mm to the next mark and repeat filling in oil with 12 pump strokes
  - Repeat procedure at all marks until the nozzle reaches stop at the rear plate.
- At a siphon for 5 connecting tubes you will reach stop at 5<sup>th</sup> mark, at siphons for e.g. 2 connecting tubes, stop will come after 2<sup>nd</sup> mark, etc.

	<p><b>CAUTION! Do not fill with more than 12 strokes per siphon.</b> The excess oil may flow in the suction tubes. Additionally the excess oil can remove the required oil in the siphon by a physical suction effect through the draining channel.</p>
---	---

	<p>The number n of internal siphons is equal to the number of pipe connections. This means, that the pump has to be used n times at varying positions.</p>
---	--

- Close the threaded hole with the plug (a small amount of oil coming out does not impact the functionality).
- Clean the outer siphon block.
- Continue with the next block.



### 3.3 Filling of siphon blocks VN180 for VN115/87plus and VN116/87plus system with oil

- Press the pump lever of the filling pump (see Figure 35) as many times until first oil drops are coming out.
- Unscrew the lower siphon block plug (see Figure 34).
- Insert filling pump nozzle (see Figure 36).



**Figure 34:** Siphon block VN180



**Figure 35:** Filling pump

- Screw in the fitting of the filling pump.
- Press the nozzle to stop position.
- Tighten the lock nut.
- Fill the siphon with 8 strokes.



**CAUTION!** Do not fill with more than 8 strokes. The excess oil may flow in the suction tubes. Additionally the excess oil can remove the required oil in the siphon by a physical suction effect through the draining channel.





**Figure 36:** Filling pump inserted and fixed in the siphon block

- Remove the filling pump.
- Close the threaded hole with the plug (a small amount oil coming out does not impact the functionality).
- Clean the siphon block.
- Continue with the next block.

### 3.4 Filling of pipe siphons for VN115/87plus and VN116/87plus system with oil



**Figure 37:** Pipe siphon

- Remove flexible hose
- Fill in 70ml lubrication oil
- Fix flexible hose again



**CAUTION!** Do not fill in more than 70ml; the excess oil can remove the required oil in the siphon by a physical suction effect through the draining channel.




### 3.5 Adjusting the sensitivity of the OMD

The detector determines the oil mist concentration by an optical measurement. The calculated values are the 'opacity' in percent. 100% opacity means that no light is transmitted through the oil mist sample. This is equivalent to a complete white wall.

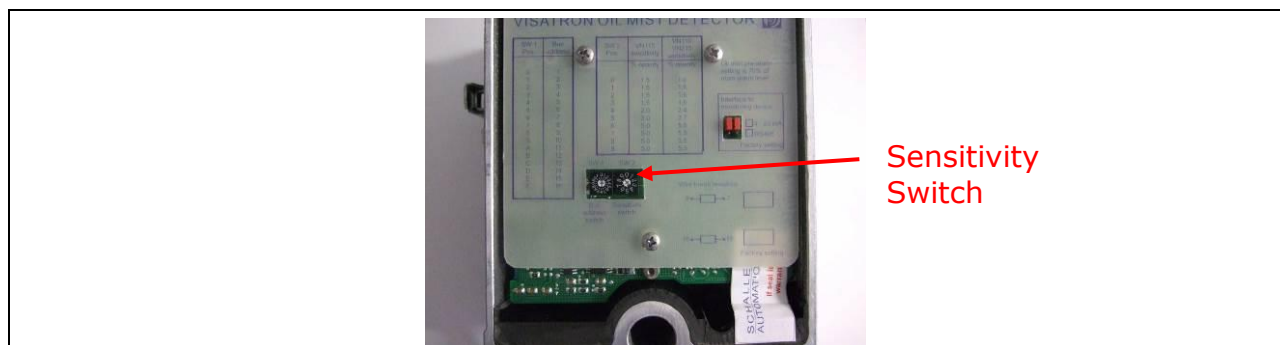
The LEL (Lower Explosion Level) is equal to 47mg/l oil mist concentration in air at a temperature of 25 °C. IACS UR M67 rules do request that OMD's do indicate an oil mist alarm latest at approx. 2.5mg/l. The lesser sensitivity level of all VN/87plus OMD's, level 6, still ensures an Oil Mist Alarm at oil mist concentrations inside the engine of <2.5mg/l. This complies fully with the requirements given by the IACS UR M67.

Position	Relative VN115 alarm level in opacity	Relative VN116/VN215 alarm level in opacity
3	1.5%	1.6%
4	2.0%	2.4%
5	3.0%	3.7%
6	5.0%	5.5%

**Table 2:** Sensitivity switch position and corresponding oil mist alarm level

	<p>Standard switch position 3 or 4 normally is sufficient for all sorts of engines. If necessary, choose the lower sensitivity level 5 or 6.</p>
---	--

The sensitivity of the VISATRON® oil mist detector can be adjusted by a switch on the rear side of the measuring head (see Figure 38).



**Figure 38:** Sensitivity switch at rear side of measuring head



### 3.6 Commissioning check list

<b>Mechanical check</b>	
Are all suction pipes installed as specified in the installation drawing?	<input type="checkbox"/> yes / <input type="checkbox"/> no
Are all fittings fastened and tight?	<input type="checkbox"/> yes / <input type="checkbox"/> no
On VN215/87plus installation: Is the arrangement of the pipes at the valve box correct?	<input type="checkbox"/> yes / <input type="checkbox"/> no
On VN215/87plus installation: Are all un-used openings at the valve box closed?	<input type="checkbox"/> yes / <input type="checkbox"/> no
On installations with siphon blocks: Are all siphon blocks filled with oil and all un-used openings closed?	<input type="checkbox"/> yes / <input type="checkbox"/> no
On installations with pipe siphon: Are all siphons filled with oil?	<input type="checkbox"/> yes / <input type="checkbox"/> no
On installations with oil separator: Is the separator filled with oil?	<input type="checkbox"/> yes / <input type="checkbox"/> no
Is the negative pressure at the measuring head adjusted to 60 mmWC?	<input type="checkbox"/> yes / <input type="checkbox"/> no
Adjusted negative pressure	mmWC

<b>Electrical check</b>	
Is the power supply connected to the terminal and is the voltage within the specified range?	<input type="checkbox"/> yes / <input type="checkbox"/> no
Measured supply voltage	Volts
Is the monitoring device installed?	<input type="checkbox"/> yes / <input type="checkbox"/> no
Are the 'Alarm' and 'Ready' signals connected to the engine control and safety system?	<input type="checkbox"/> yes / <input type="checkbox"/> no
Are the correct wire break resistors installed	<input type="checkbox"/> yes / <input type="checkbox"/> no
Value of wire break resistor	kOhm
Is the correct interface mode at pin 11 and 13 selected?	<input type="checkbox"/> yes / <input type="checkbox"/> no

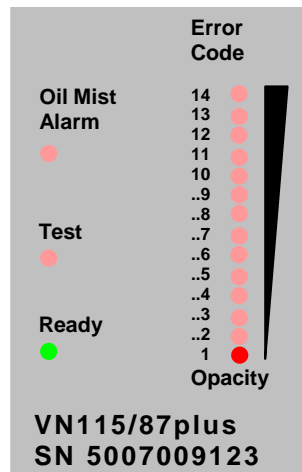
<b>Functional check</b>	
On vessels perform the on-board test with test plate. Test positive?	<input type="checkbox"/> yes / <input type="checkbox"/> no
At engine factory perform smoke test. Test positive?	<input type="checkbox"/> yes / <input type="checkbox"/> no
On VN115/87plus installations, as an alternative to the smoke test, measure the negative pressure at the end of the suction pipes. Values as specified?	<input type="checkbox"/> yes / <input type="checkbox"/> no



## 4 Operating instructions

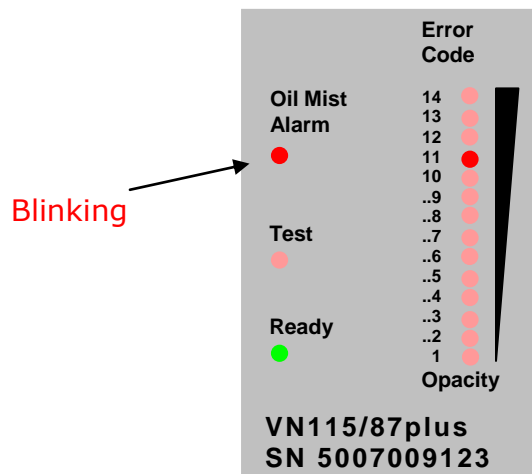
### 4.1 Display

After power-on LED 1 is blinking for 30 seconds. The device will show the following display.



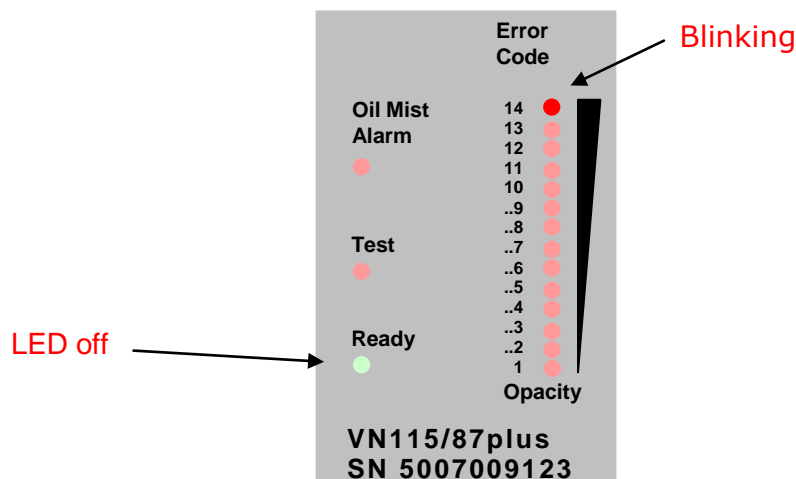
**Figure 39:** Normal display mode

In case of a high oil mist concentration the LED bar goes up and at 70 % opacity compared to the adjusted alarm level the 'Oil-Mist Alarm' LED switches on. At 100% opacity, compared to the alarm level, the 'Oil-Mist Alarm' LED starts blinking. If the opacity later goes down, later the alarm condition will be stored.



**Figure 40:** Example of an oil mist alarm state

The opacity is shown in the right LED bar. If highest LED is switched on the opacity has reached / exceeds the Oil Mist Alarm level.



**Figure 41:** Device not ready, example of 'Negative pressure too low'


If a device internal error or a system failure occurs the diagnostics system shows the failure condition by a blinking LED on the LED bar. The error codes are shown in Table 3. A detected oil mist alarm is displayed at this time with the 'Test' LED. In this case the alarm relay or shutdown relay is not switched on.

Blinking LED on display	Series VN87plus device failures
14	Negative pressure/airflow too low
13	Optical sensor dirty
12	Voltage of internal battery too low
11	Ambient temperature too low (<0°C)
10	Ambient temperature too high (>70°C)
9	Electronics temperature too low (<0°C)
8	Electronics temperature too high (>75°C)
7	Reset button defective
6	Supply voltage too high
5	Switch for adjusting sensitivity defective
4	Optical sensor defective
3	Airflow-sensor defective
2	Electronic module defective
1	Blinking: Startup phase

**Table 3:** Error codes



4.2 Reset of Oil Mist Alarms

	<p><b>CAUTION!</b></p> <p><b>Use a monitoring device at a safe location (e.g. ECR) to check for the actual oil mist concentration that is requested by the IACS. In case of an Oil Mist Alarm, Schaller Automation strongly recommends to approach the engine only after indicated oil mist concentration (LED chain) has lowered to half of its bar indication (VISATRON®-device and Remote Indicator II).</b></p> <p><b>Follow the instructions of engine builder, ship yard and ship owner!</b></p> <p><b>In case of a High Oil Mist Alarm the Detector can be reset if the Oil Mist Concentration has lowered below the Alarm level.</b></p>
---	--

The alarm condition can be reset only by pressing the Oil-Mist-Alarm RESET button.



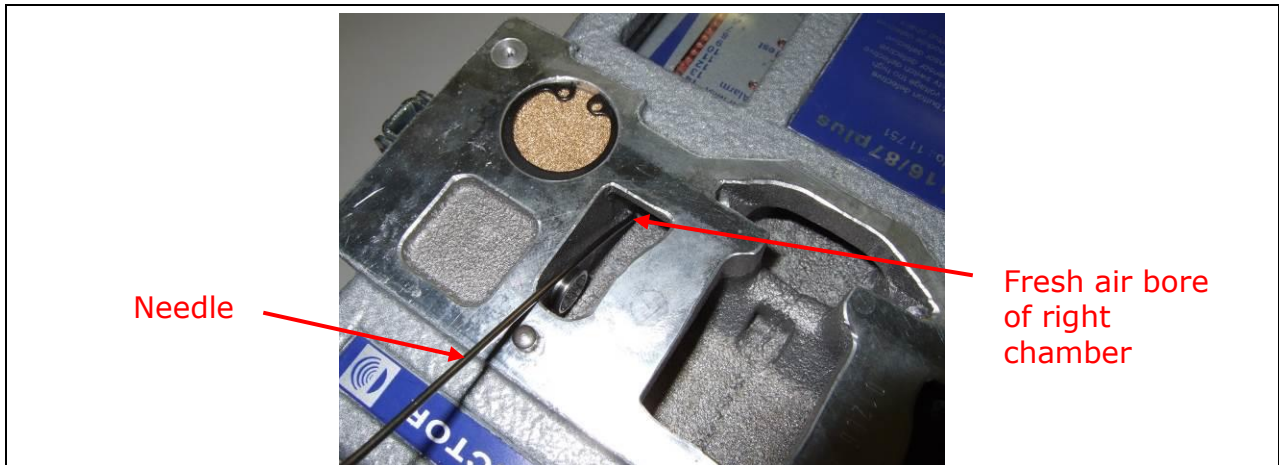


## 5 Troubleshooting

Error	Description	remedy	Chapter
14	Negative pressure / airflow too low	<ol style="list-style-type: none"> <li>1. Adjust suction pressure</li> <li>2. Exchange air filters</li> <li>3. Clean fresh air bores</li> <li>4. Check suction system</li> <li>5. Exchange bellows</li> <li>6. Exchange filter cartridge (optional)</li> <li>7. Exchange measuring head</li> </ol>	3.1 page 31 5.3 page 43 5.1 page 42 5.6 page 46 8.4 page 77 5.5 page 44
13	Optical sensor dirty	<ol style="list-style-type: none"> <li>1. Clean infrared filter</li> </ol>	5.2 page 42
12	Voltage of internal battery too low	<ol style="list-style-type: none"> <li>1. Exchange measuring head</li> </ol>	5.5 page 44
11	Ambient temperature too low (<0°C)	<ol style="list-style-type: none"> <li>1. Remove ambient cooling components</li> </ol>	
10	Ambient temperature too high (>70°C)	<ol style="list-style-type: none"> <li>1. Remove or turn away ambient heating components</li> <li>2. Install metal heat shields against radiation</li> </ol>	
9	Electronics temperature too low (<0°C)	<ol style="list-style-type: none"> <li>1. Remove ambient cooling components</li> </ol>	
8	Electronics temperature too high (>75°C)	<ol style="list-style-type: none"> <li>1. Remove or turn away ambient heating components</li> <li>2. Install metal heat shields against radiation</li> </ol>	
7	Reset button defective	<ol style="list-style-type: none"> <li>1. Eliminate blocking</li> <li>2. Exchange Measuring head</li> </ol>	5.5 page 44
6	Supply voltage too high	<ol style="list-style-type: none"> <li>1. Measure supply voltage</li> <li>2. Exchange measuring head</li> </ol>	5.5 page 44
5	Switch for adjusting sensitivity defective	<ol style="list-style-type: none"> <li>1. Exchange measuring head</li> </ol>	5.5 page 44
4	Optical sensor defective	<ol style="list-style-type: none"> <li>1. Clean infrared filter</li> <li>2. Exchange measuring head</li> </ol>	5.2 page 42 5.5 page 44
3	Airflow-sensor defective	<ol style="list-style-type: none"> <li>1. Exchange measuring head</li> </ol>	5.5 page 44
2	Electronic module defective	<ol style="list-style-type: none"> <li>1. Exchange measuring head</li> </ol>	5.5 page 44
	All LED off	<ol style="list-style-type: none"> <li>1. Measure supply voltage</li> <li>2. Activate Self-repair of Polyfuse</li> <li>3. Replace measuring head fuse</li> <li>4. Check for earth fault problem</li> <li>5. Exchange measuring head</li> </ol>	5.7 page 41 5.7 page 41 5.8 page 48 5.5 page 44




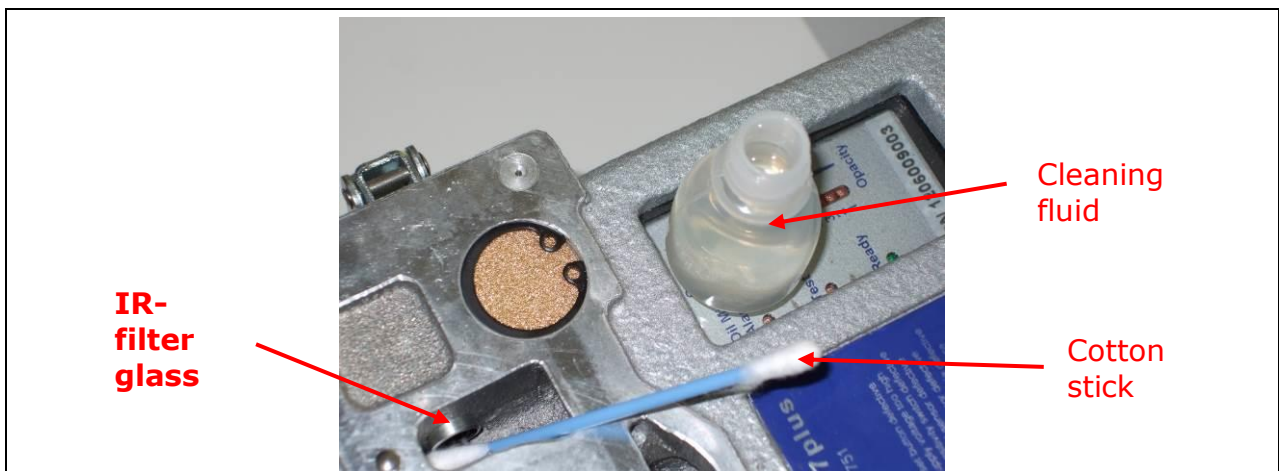
**5.1 Clean fresh air bores**




**Figure 43:** Cleaning of fresh air bore in the left and the right chambers

**5.2 Clean infrared (IR-) filter**

	<p><b>CAUTION!</b> Dirty IR-filter glass may cause a loss of sensitivity of the device. Clean filters acc. maintenance plan (page 50)</p>
--	---



**Figure 44:** Cleaning of IR-Filter glass in the left and the right chamber

	<p><b>WARNING!</b> Use only cleaning fluids for optical components as delivered in the service box.</p>
---	---



### 5.3 Exchange air filters in the measuring head

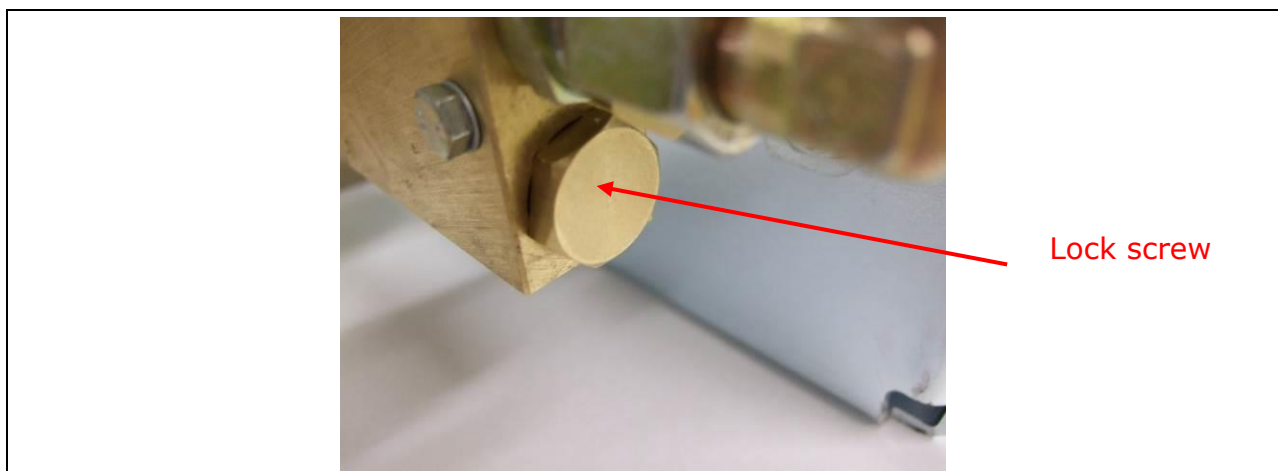


**Figure 45:** Exchange of the air filters



**WARNING!** Do not try to clean the filters, use always new ones.

### 5.4 Exchange air filter in pressure regulator unit



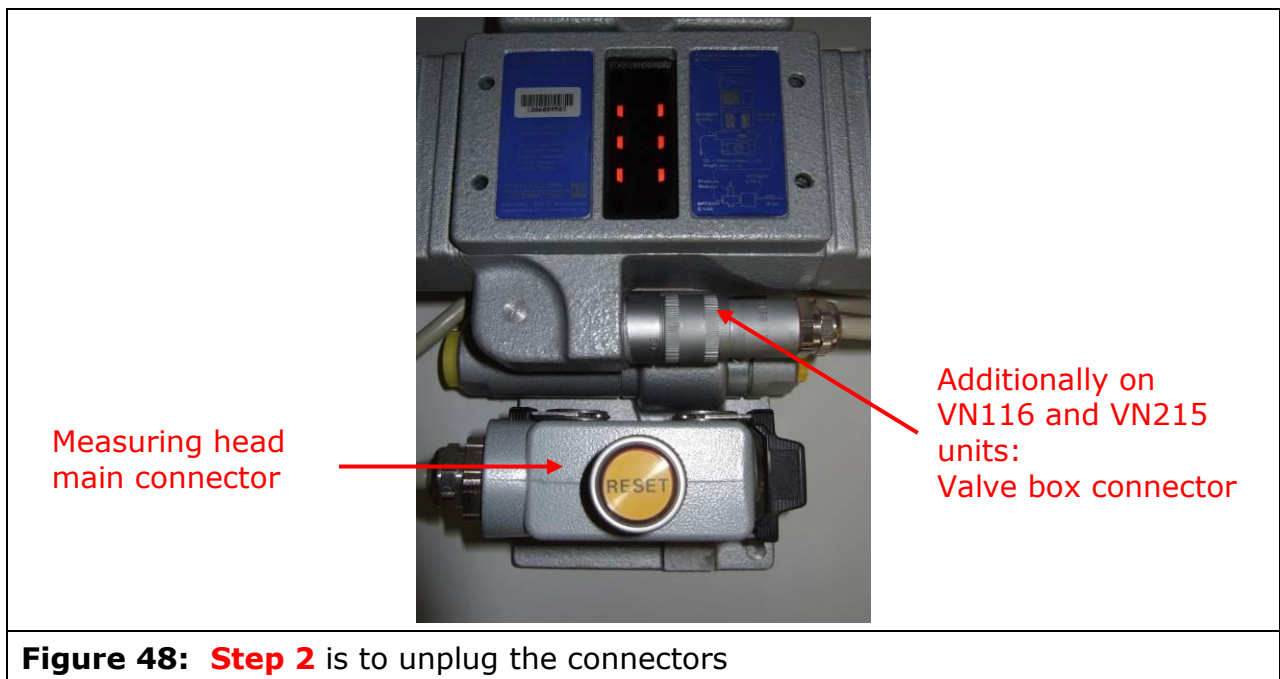
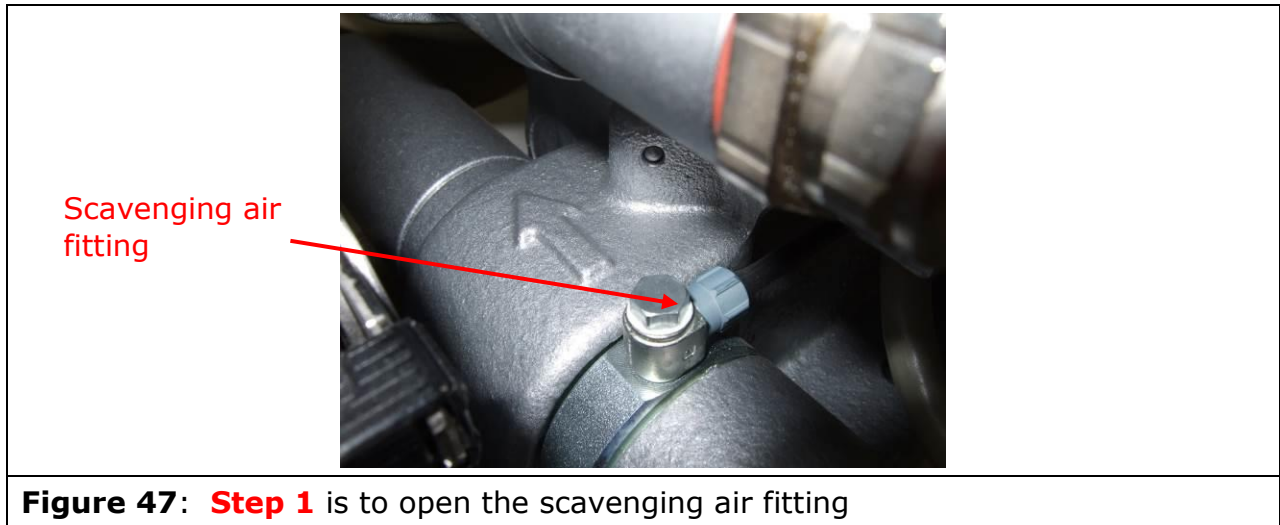
**Figure 46:** The air filter is behind the lock screw of the throttle block



**WARNING!** Switch off the compressed air supply during the maintenance work. After the exchange re-check the negative suction pressure.



### 5.5 Exchange measuring head





**Figure 49:** Step 3 is to unscrew the measuring head

To mount the new measuring head execute the 3 steps in reverse order.



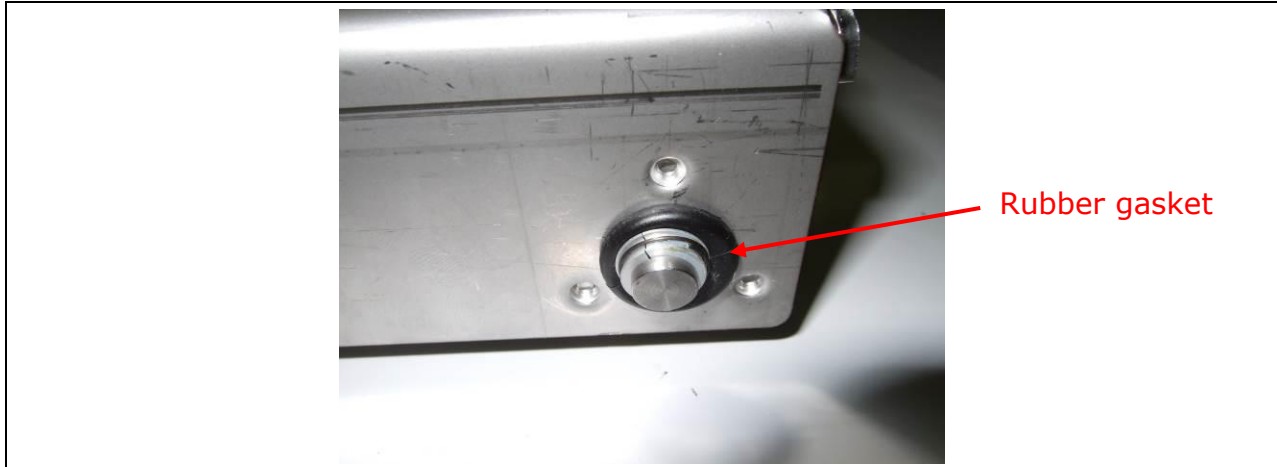
**WARNING!** Check the values of the wire break resistors or in case of doubt use the old ones.



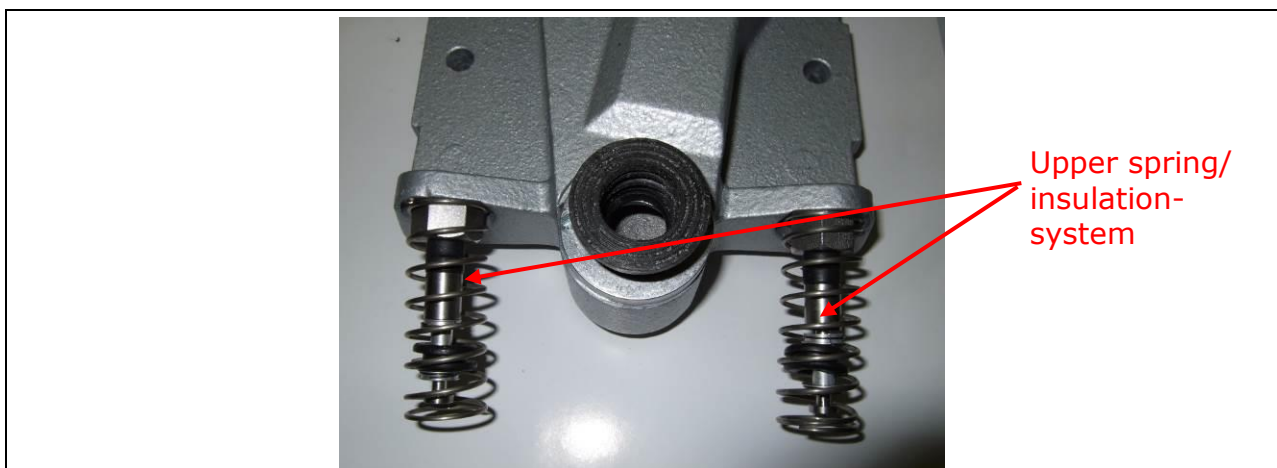


## 5.6 Exchange bellows and suspension-system

**Step 1** is to dismount the measuring head.

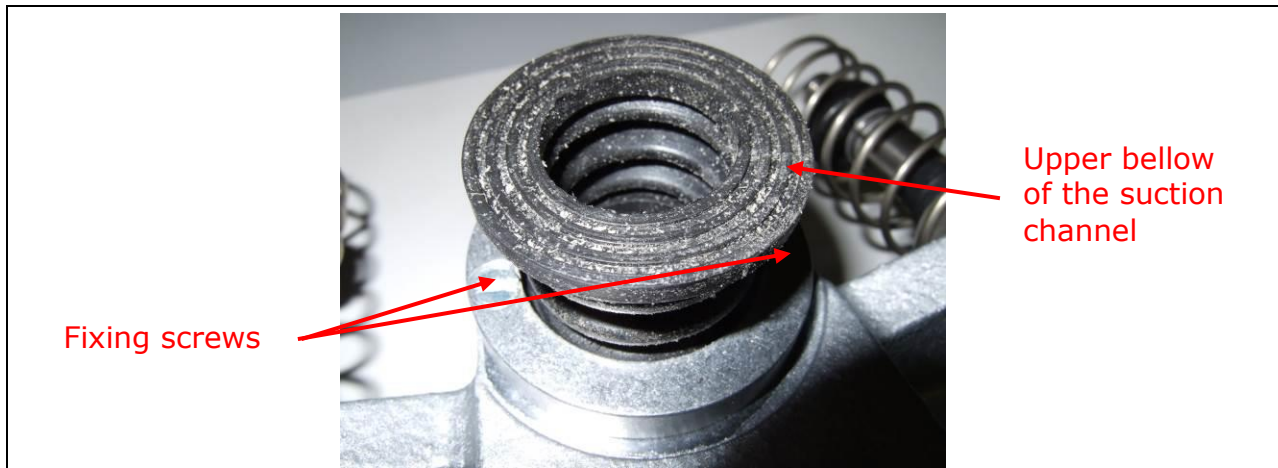


**Figure 50:** **Step 2** is to press out the 4 rubber gaskets with a blunt tool and finally to remove the carrier plate

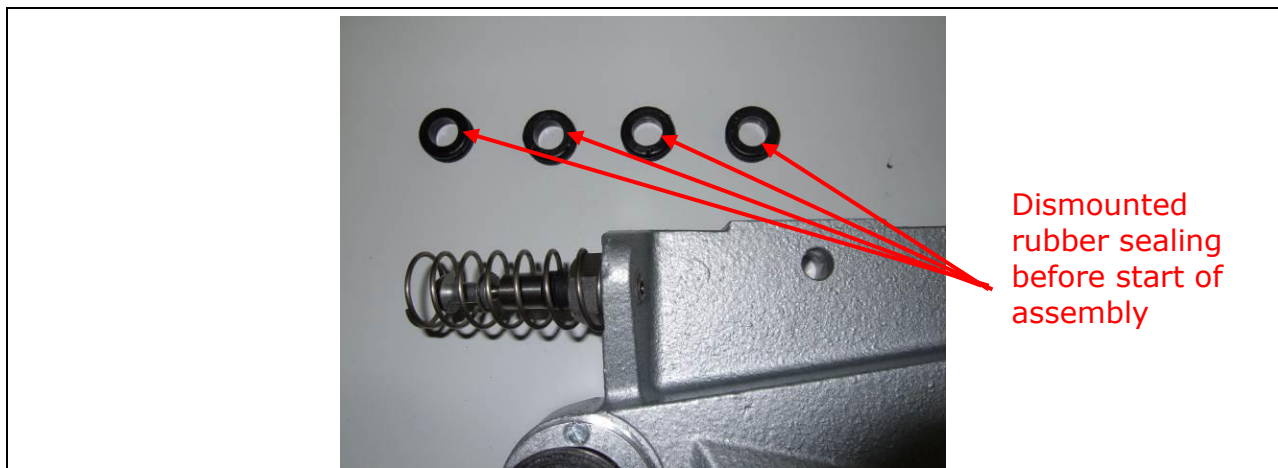


**Figure 51:** **Step 3** is to exchange the suspension-system if necessary





**Figure 52:** Step 4 is to exchange the 2 bellows if necessary. The bellow is secured by a ring which is fixed by two screws.



**Figure 53** Step 5 is to pull out the gaskets before the carrier plate is mounted

To finish the assembly execute the first 2 steps in reverse order.



### 5.7 Measuring head fuses



**Figure 54** Fuse on the rear side of the measuring head

The device has two internal fuses. The first is located in the main connector of the measuring head. This is a 'self-repairing' fuse which protects the filter circuit in the connector.

To reset this fuse, unplug the main connector and **wait 5 minutes** before you plug it again.



**WARNING!** Unplug the main connector during the exchange of the fuse.

If all LED's remain off exchange the 2A semi lag fuse II at the rear side of the measuring head (see Figure 54).





5.8 Check for earth fault problem

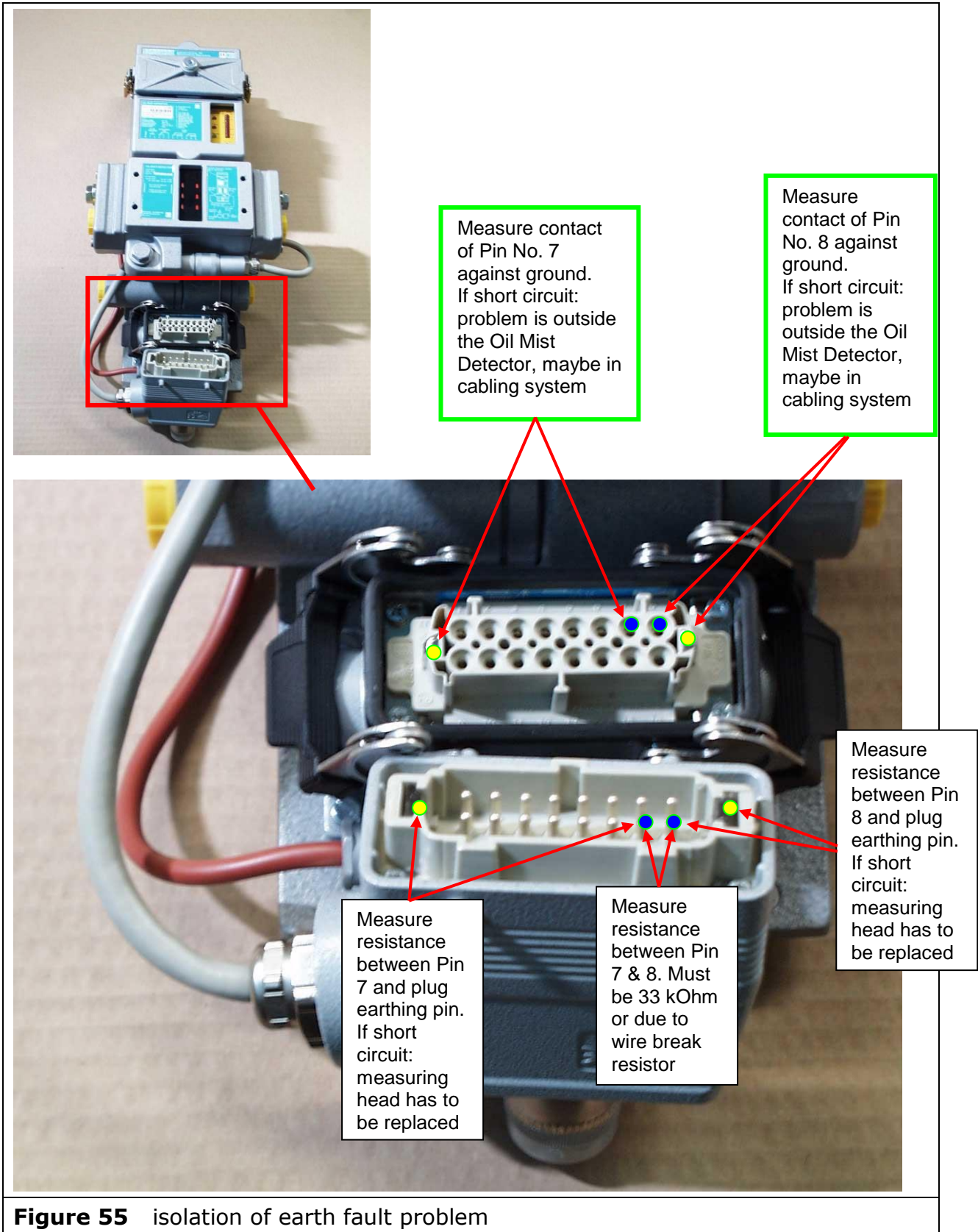


Figure 55 isolation of earth fault problem



In case all LED's remain off despite fuses are ok, perform check as shown in Figure 55. Often it happens during welding work around the engine or in engine room that electrical current of high energy passes through detector and its electrical wiring.

As a result, possible bursts and peaks may cause damage inside the measuring head. In that case, only a replacement of the measuring head helps.



**WARNING!**

Unplug the main connector during welding work around the engine or in engine room!



**6 Maintenance procedures**

**CAUTION!** Maintenance work has to be done when engine is stopped.

Step	Description	Interval (whatever comes first)								See Section	Required Parts / Tools
	Hours,	2.000	4.000	6.000	8.000	10.000	12.000	14.000	16.000		
	or Months	3	6	9	12	15	18	21	24		
1	Check negative pressure in Measuring Head: - under 55 mmWC -> adjust pressure - between 55 mmWC and 65 mmWC -> o. k. - between 65 mmWC and 85 mmWC -> adjust pressure - over 85 mmWC -> check pressure regulator unit	X	X	X	X	X	X	X	X	3.1, Page 31	270532 U-Tube Gauge Kit or 151800 Digital Pressure Gauge compl.  270443 Service Kit Pressure Regulator
2	Clean infrared filters in Measuring Head	X	X	X	X	X	X	X	X	5.2, Page 42	151482 Cleaning Kit
3	Clean fresh air bores in Measuring Head	X	X	X	X	X	X	X	X	5.1, Page 42	
4	Exchange air filters in Measuring Head	X	X	X	X	X	X	X	X	5.3, Page 43	151481 Maintenance Kit
5	Perform functional test with test glass	X	X	X	X	X	X	X	X	7.1, Page 53	270453 Test Plate Kit
6	Exchange air filters in Pressure Regulator Unit		X		X		X		X	5.4, Page 43	151481 Maintenance Kit
7	Exchange filter cartridge (VN115/116/215/87plus)		O		O		O		O	8.4, Page 77	273119 Cartridge for Water separator
8	Clean suction system with compressed air				X				X	3, Pages 31/32	Compressed air
9	Check bellows for cracks and suspensions between Measuring Head and Baseplate				X						
10	check Scavenging air outlet manually (feel free airflow)				X				X		
11	Inspection of entire OMD system								S		<b>Schaller Service</b>
12	Perform functional test of entire OMD system with smoke								S		<b>Schaller Service</b> 151067 Smoke Generator (110V) resp. 150740 (230V)
13	Overhaul complete OMD, incl. exchange bellows and suspension								S		<b>Schaller Service</b> 151482 Cleaning Kit, as per model: VN115 – 151483 VN116 – 151484 VN215 - 151485



**Explanation of Page 51 – Maintenance procedures:**

**X** – Work to be done


**O** – Optional, only if optional Water Separator is installed

**S** – By authorized and certified Schaller Service Staff only




## 7 Functional test

### 7.1 On board test



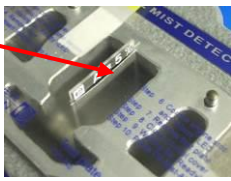
	Attention: Before starting the on board test execute the procedures as specified in the maintenance schedule. The pipe system has to be clean and if used all siphons have to be filled with oil (refer to chapter 2.1.3.)
---	--

Using the test plate set, included in this manual folder, you can easily test the functionality of the VISATRON® oil mist detectors and their connection to the safety system of the engine. The set can also be ordered separately under Part.-No. 270453. It consists of the following parts:


<ul style="list-style-type: none"> <li>• Test plate (A)</li> <li>• Test glass (B)</li> <li>• Working instruction</li> </ul>	<b>A</b>		<b>B</b>	
---	----------	---	----------	--


	<b>Attention: You will stop or slow down the engine.</b>
---	--

Test procedure step by step:

Step 1	Open the <b>latches</b> of the OMD control cover and flip the cover to the left side.	
Step 2	Press the test plate onto the <b>openings</b> . Ensure that the openings are completely covered. Now the device starts to create the negative suction pressure again.	
Step 3	Wait for the 'Ready'-LED on the display.	
Step 4	Insert the <b>test glass into the slot</b> of the test plate. The glass simulates oil mist and generates an oil mist alarm.	
Step 5	Wait for the 'Alarm'-LED. At this comes on, the	



	engine has to stop or to enter the slow down mode.	
Step 6	Remove the test plate and put it together with the test glass back into the bag.	
Step 7	Close the control cover carefully.	
Step 8	Wait for the 'Ready'-LED.	
Step 9	Press the <b>Oil-Mist-Alarm RESET button</b> to acknowledge the alarm state and enter the normal monitoring mode.	


	If LED14 is blinking and the Oil-Mist-Alarm RESET button is pressed the OMD device enters a test mode. In this test mode the LED bar displays the measured opacity. After pressing the Oil-Mist-Alarm RESET button again the OMD device exits the test mode and LED14 is blinking again.
---	--

If applicable perform an additional pressure measurement to check the tightness of the suction system as described in chapter 7.3. Instead of an electronic gauge you can use the U-pipe manometer of the service box.



**7.2 Factory test at engine builder with smoke generator on VN115/87plus and VN116/87plus installations**

Both installation types can be verified by a smoke test. Due to vessels not normally having the equipment, SCHALLER AUTOMATION recommends this procedure only for the factory test by using the SCHALLER smoke generator (see Figure 56). If a smoke generator is available on a vessel this test can be also performed, however, in this case observe the following warning.

	<p>Attention: Before starting the on board test execute the procedures as specified in the maintenance schedule. The pipe system has to be clean and if used <b>all siphons have to be filled with oil</b> refer to chapter 2.1.3.</p>
---	--

A test of the entire OMD system (incl. tubing system) can be done only at standstill of the engine. The crankcase service covers must be opened first. Put a small amount of smoke fluid (see Chapter 'Accessories') into the reservoir and switch on the generator for a few seconds until the storage tank is completely filled with smoke. This is important so that the tank can provide sufficient smoke to complete the search run of a VN116/87plus installation to determine the correct engine side. The last step is to hold the flexible hose directly into the suction funnels until an oil mist alarm is indicated.



**Figure 56:** SCHALLER AUTOMATION smoke generator, see 'Accessories'

If it's not possible to open the service covers a functional test can be performed without testing the suction funnels.






In this case the flexible hose has to be pressed over the opening under the lock screws of the siphon blocks as seen in Figure 57 or has to be pressed over the open header pipe end after removing the lock nut.

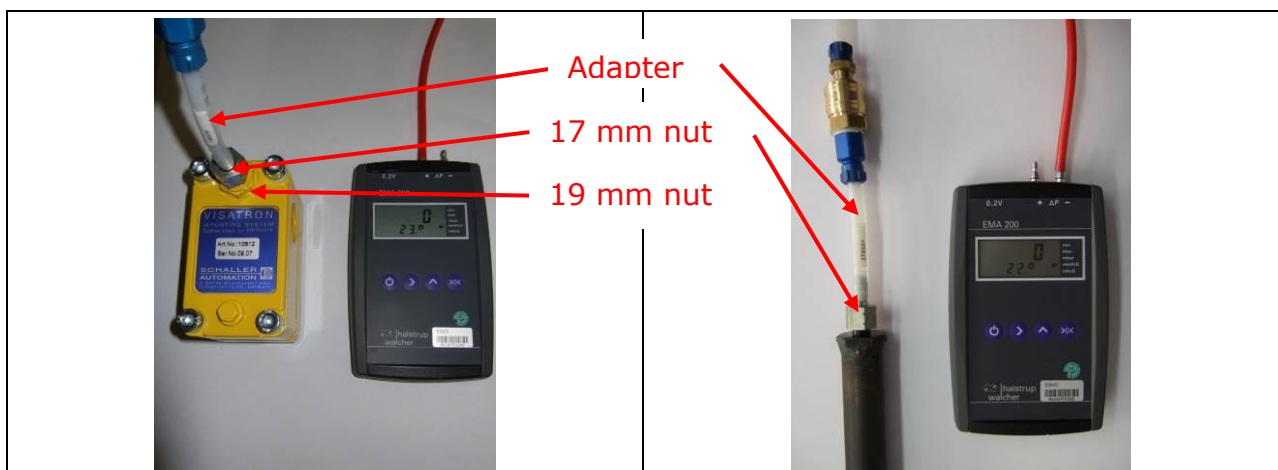


**Figure 57:** Test inlet on the siphon blocks VN180

	<p>Attention: In case of siphon block VN180 installation you have to test all compartments and the additional suction points at running engine.</p>
---	---

### 7.3 Additional pressure measurement on VN115/87plus and VN116/87plus installations

Perform the functional and smoke test as shown in the previous chapters 'On board test' and 'Factory test with smoke generator'.



**Figure 58:** Manometer (not scope of supply) connected to siphon block VN180

**Figure 59:** Manometer (not scope of supply) connected to header pipe

Then carry out a pressure measurement at the end of the suction system. The engine including the oil pump must be at standstill.







Attention: You will only measure correct values with engine and lube oil pump at standstill.

On a VN115/87plus and VN116/87plus installation the tightness of the suction system can be determined by a pressure measurement at the outer siphon blocks or at the end of the header pipes.

This siphon block has an additional fitting for a manometer (see Figure 58). To remove the 17 mm lock nut you have to counter the 19 mm nut with a jaw wrench.

The pressure measurement procedure can also be performed at the end of the 22 mm diameter suction pipes which are delivered from SCHALLER AUTOMATION. These pipes have also fittings for the manometer at the pipe end (see Figure 59).

Use only a digital manometer with a differential measuring method. On completion do not forget to lock all openings.

The minimal negative pressure values are defined in Table 4. They are only valid if a negative pressure of **60 mm WC** is adjusted at the measuring head.

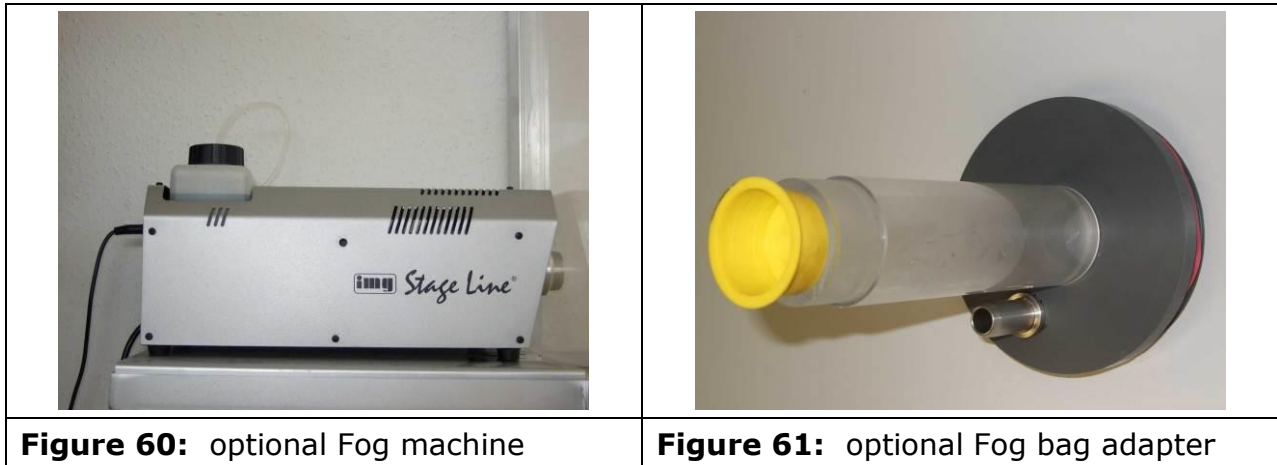
VN115/87plus	>6.5 mmWC
VN116/87plus, VN215/87plus	>1.5 mmWC

Table 4: Minimal pressure values **at the end** left and right of the suction tubing system



### 7.4 Factory test at engine builder with fog machine on all installations

This test includes the indication of an oil mist alarm as well as the indication of the affected compartment. Instead of the above mentioned smoke generator you have to use the more powerful fog machine (see Figure 60) with a fog bag with adapter (see Figure 61).




This equipment guarantees a constant fog concentration during the test and due to high density no influence of the additionally sucked in crankcase atmosphere.

Due to the increasing request of the ship owners and classification societies to test the OMD-System at running engines SCHALLER AUTOMATION recommends now following procedure.

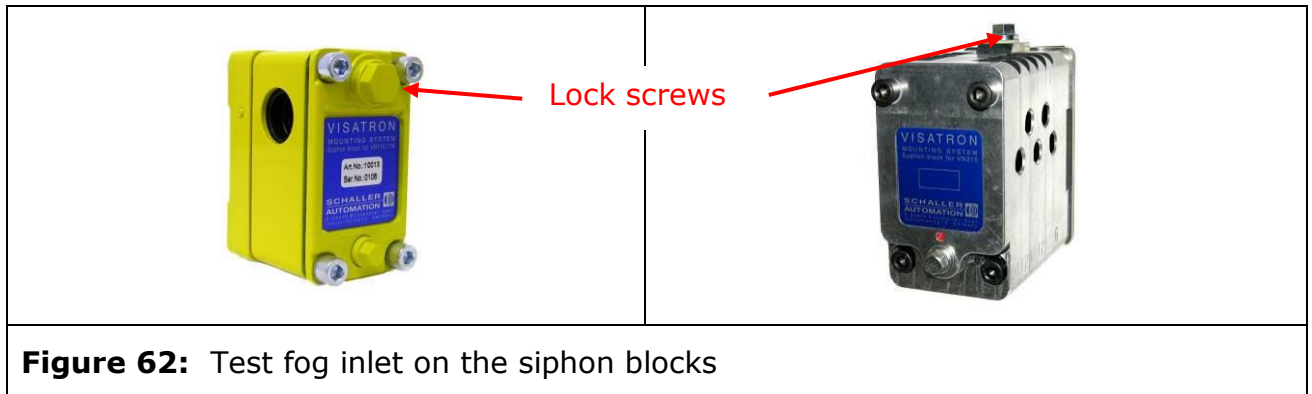
The first test must be performed at standstill to secure, that the engine is well protected by the OMD system. If it is not possible to open the service covers or if it is not possible to access the suction funnels, e.g. on large 2-stroke engines, a functional test can be performed alternatively using a special connection on the siphon block or respectively on the T-engine wall connection.


Fill the fog bag completely with fog and close the adapter with the yellow cap. The next step is to press the flexible hose of the fog bag adapter over the opened plug at the side of the siphon blocks as seen in **Figure 62** or over the open tube end at T-engine wall connections. Do not remove the hose until an oil mist alarm is indicated and the search run to indicate the affected compartment is finished. The plugs can be countered by an 11 mm jaw wrench to open or close the lock screw.

	<p>Attention: Let in fog at sampling points of all compartments including chain/gear drive.</p>
---	---

The second test can be performed on request at running engine using the plugs of the siphon block or the T-engine-wall connection to induce the fog.





	<p>A wrong compartment indication (VN215/87plus) can be caused either by:</p> <ul style="list-style-type: none"> <li>• Empty fog bag: → Repeat the test with a full bag or</li> <li>• Empty siphon block → Drain all siphon blocks of the affected side completely by opening the 4 screws on the front side and refill the siphons again</li> </ul>
---	--



## 8 Optional Spare Parts and Accessories

Part-No. new	Part-No. old	Description	Quant. per OMD	Pos. Fig. 69-71
150993	11079	Service box	1	
11651	11651	Measuring head VN115/87plus; 33k; RS485; sensitivity level 4 *	1	36
11751	11751	Measuring head VN116/87plus; 33k; RS485; sensitivity level 4 *	1	36
10851	10851	Measuring head VN215/87plus; 33k; RS485; sensitivity level 4 *	1	36
270399	10727	Control cover measuring head series VN87plus devices	1	37
11752	11752	Valve box VN116/87plus	1	38
11852	11852	Valve box VN215/87plus	1	39
365206	10002	Air filter - pressure regulator unit (2 pcs.)	1	10
365197	10042	Scavenging air filter (10 pcs.)	2	3
190003	10135	Cleaning needle (30 pcs.)	1	31
452176	10036	Cotton sticks to clean IR-filters (300 pcs.)	1	33
200548	10046	U-pipe manometer	1	1
270502		Manometer adapter for siphon block VN180	1	
270089	10040	Bottle with slacked water	1	16
270493	10053	Manometer adapter for control cover	1	30
330721	10405	Gasket for valve box (5 pcs.)	1	34
360132	10406	Sealing for oil draining in valve box	1	4
360133	10407	Sealing for suction channel in valve box	1	18
310526	10087	Fuse cap	1	40
436513	10043	Fuse 2A semi time lag (10 pcs.)	1	5
350001	10409	Clamp plate VN215 valve box connection	2	12
365193	10023	Flexible bellows of suction channels (4 pcs.)	2	9
365198	10041	Circlip for scavenging air filter (20 pcs.)	2	32
360079	10411	Rubber plate for VN215 valve box connection	2	29
360194	10412	Rubber plugs for unused valve box connections	3	8
200175	11004	Main connector socket	1	41
270303	10726	Scavenging air hose	1	42
330482		Gasket for measuring head (5 pcs.)	1	43
270608		Gasket set siphon VN280	1	

**Table 5:** Optional Spare parts

\* Other versions are also available on enquiry.



Part-No. new	Part-No. old	Description
150993	11079	Service box series VN87plus
151055	11000	Commissioning box series VN87plus
180062	11078	Manual DVD series VN87plus
151072	10001	Pressure regulator unit with input throttle
270888	10753	Protection cover
150938	11163	Oil separator for air outlet
150939	11164	Pipe siphon
150929	10140	Siphon block VN280 1 connection
150931	10142	Siphon block VN280 2 connection
150932	10143	Siphon block VN280 3 connection
150933	10144	Siphon block VN280 4 connection
150934	10145	Siphon block VN280 5 connection
150930	10141	Siphon block VN280 1 connection with manometer fitting
271544	10160	Mounting plate VN280
270409	11062	Oil pump VN280
340115	10091	Blind plug VN280
150260	10013	Siphon block VN180
150166	10612	Siphon block VN180 with manometer fitting
270504	10089	Mounting plate VN180
270371	10062	Oil pump VN180
340375	10640	Blind plug VN180
150740	10353	Smoke generator, 230 Volts
151067	11089	Smoke generator, 110 Volts
451209	10097	Smoke fluid
151167	11049	Fog machine complete
450137	11052	Fog fluid
270453	11072	Test-plate kit
150998	11506	Monitoring device Remote Indicator II
230140	11503	Bus-cable 10m for monitoring devices
	Depends on engine type	Suction funnel
	Depends on engine type	Engine wall connection

**Table 6:** Optional Accessories



8.1 Service Kits

8.1.1 Maintenance Kit



Figure 63: Maintenance Kit – Part No. 151481

Material	Description	Quant.	Pos. Fig. 69-71
365197	Scavenging air filters	10	3
365198	Circlip for scavenging air filter	4	32
365206	Air filter for pressure regulator unit	3	10
365208	O-ring pressure regulator unit	3	19

Table 7: Content of Maintenance Kit





8.1.2 Cleaning Kit

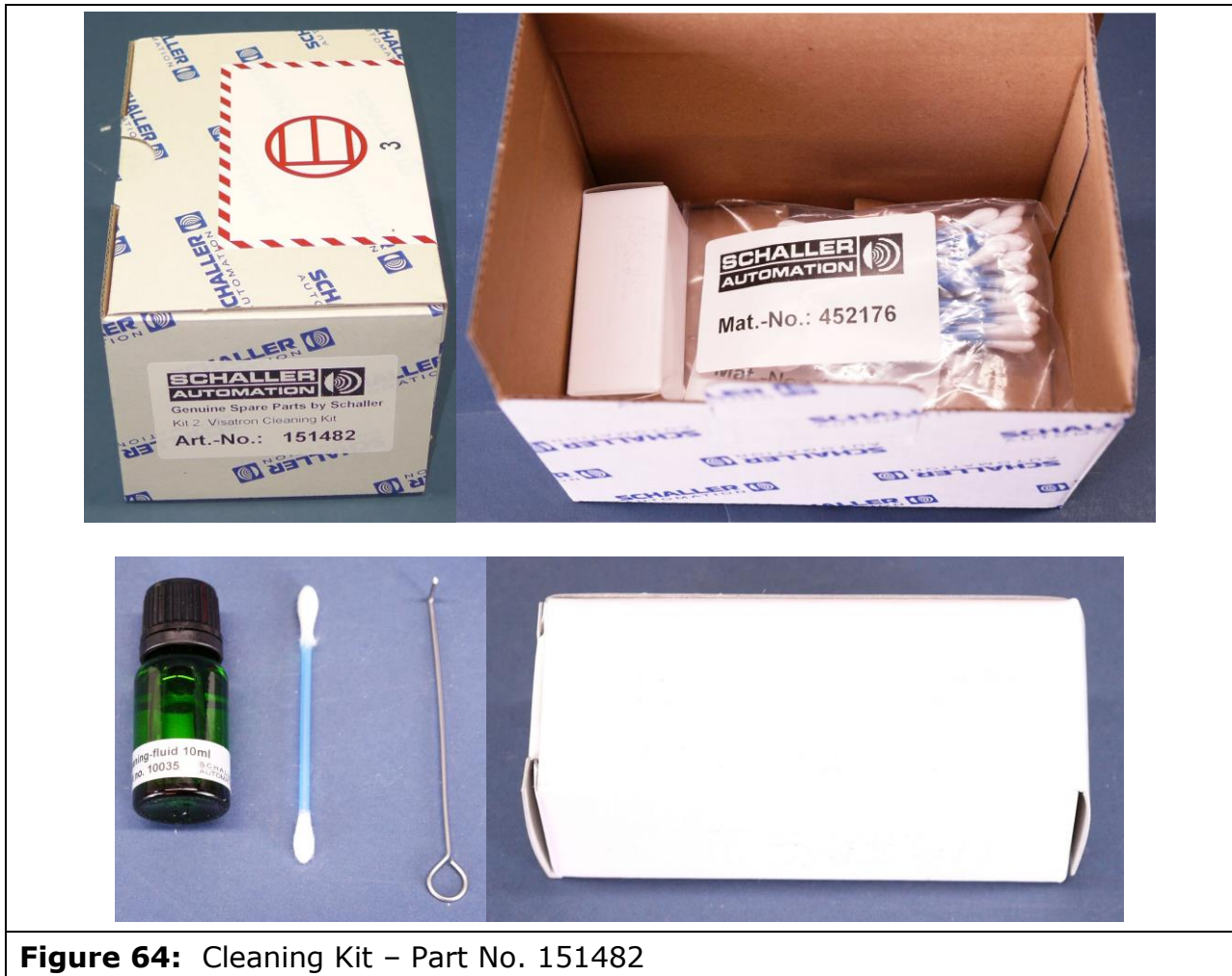


Figure 64: Cleaning Kit – Part No. 151482

Material	Description	Quant.	Pos. Fig. 69-71
190003	Cleaning needle	1	31
452176	Cotton sticks to clean IR-filters	20	33
*	Bottle with cleaning fluid	1	17

Table 8: Content of Cleaning Kit

\* Only available in combination with this cleaning kit



8.1.3 Service Kit for VN115



Figure 65: Service Kit for VN115 – Part No. 151483

Material	Description	Quant.	Pos. Fig. 69-71
330482	Gasket for measuring head	1	43
330721	Gasket for valve box	1	34
200211	Suspension elements bottom	2	13
200212	Suspension elements top	2	14
365197	Scavenging air filters	2	3





365206	Air filter for pressure regulator unit	1	10
365198	Circlip for scavenging air filter	2	32
365193	Flexible bellows of suction channels	2	9
480314	Screw for flange flexible bellows	4	51
365208	O-ring pressure regulator unit	1	19
365449	O-ring screw throttle	1	52
365954	O-ring	1	53
330543	Gasket to air-jet pump	3	54
360136	Oil return gasket	1	55

**Table 9:** Content of Service Kit for VN115



8.1.4 Service Kit for VN116



Figure 66: Service Kit for VN116 – Part No. 151484

Material	Description	Quant.	Pos. Fig. 69-71
330482	Gasket for measuring head	1	43
330721	Gasket for valve box	1	34
355346	Gasket for tube connection	2	50
200211	Suspension elements bottom	2	13



200212	Suspension elements top	2	14
365197	Scavenging air filters	2	3
365206	Air filter for pressure regulator unit	1	10
365198	Circlip for scavenging air filter	2	32
365193	Flexible bellows of suction channels	2	9
480314	Screw for flange flexible bellows	4	51
365208	O-ring pressure regulator unit	1	19
365449	O-ring screw throttle	1	52
365954	O-ring	1	53
330543	Gasket to air-jet pump	3	54
360132	Oil return gasket VN116/215	1	56
360133	Oil-mist gasket valve box VN116/215	1	57

**Table 10:** Content of Service Kit for VN116





8.1.5 Service Kit for VN215



Figure 67: Service Kit for VN215 – Part No. 151485



Material	Description	Quant.	Pos. Fig. 69-71
330482	Gasket for measuring head	1	43
330721	Gasket for valve box	1	34
200211	Suspension elements bottom	2	13
200212	Suspension elements top	2	14
365197	Scavenging air filters	2	3
365206	Air filter for pressure regulator unit	1	10
365198	Circlip for scavenging air filter	2	32
365193	Flexible bellows of suction channels	2	9
480314	Screw for flange flexible bellows	4	51
365208	O-ring pressure regulator unit	1	19
365449	O-ring screw throttle	1	52
365954	O-ring	1	53
330543	Gasket to air-jet pump	3	54
360132	Oil return gasket VN116/215	1	56
360133	Oil-mist gasket valve box VN116/215	1	57
360079	Rubber plate for VN215 valve box connection	2	29
360194	Rubber plugs for unused valve box connections	5	8

**Table 11:** Content of Service Kit for VN215



8.2 Optional Service Box

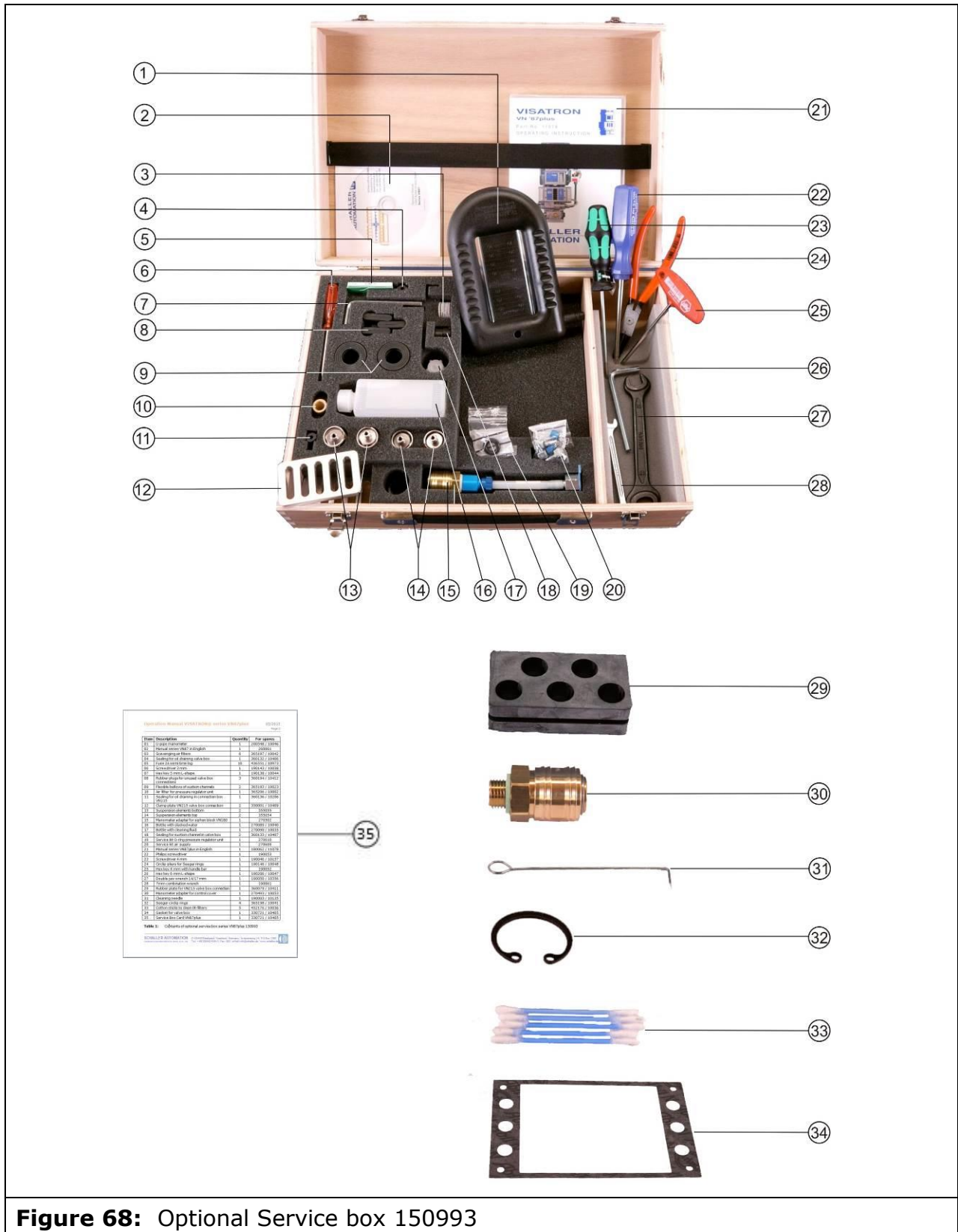


Figure 68: Optional Service box 150993

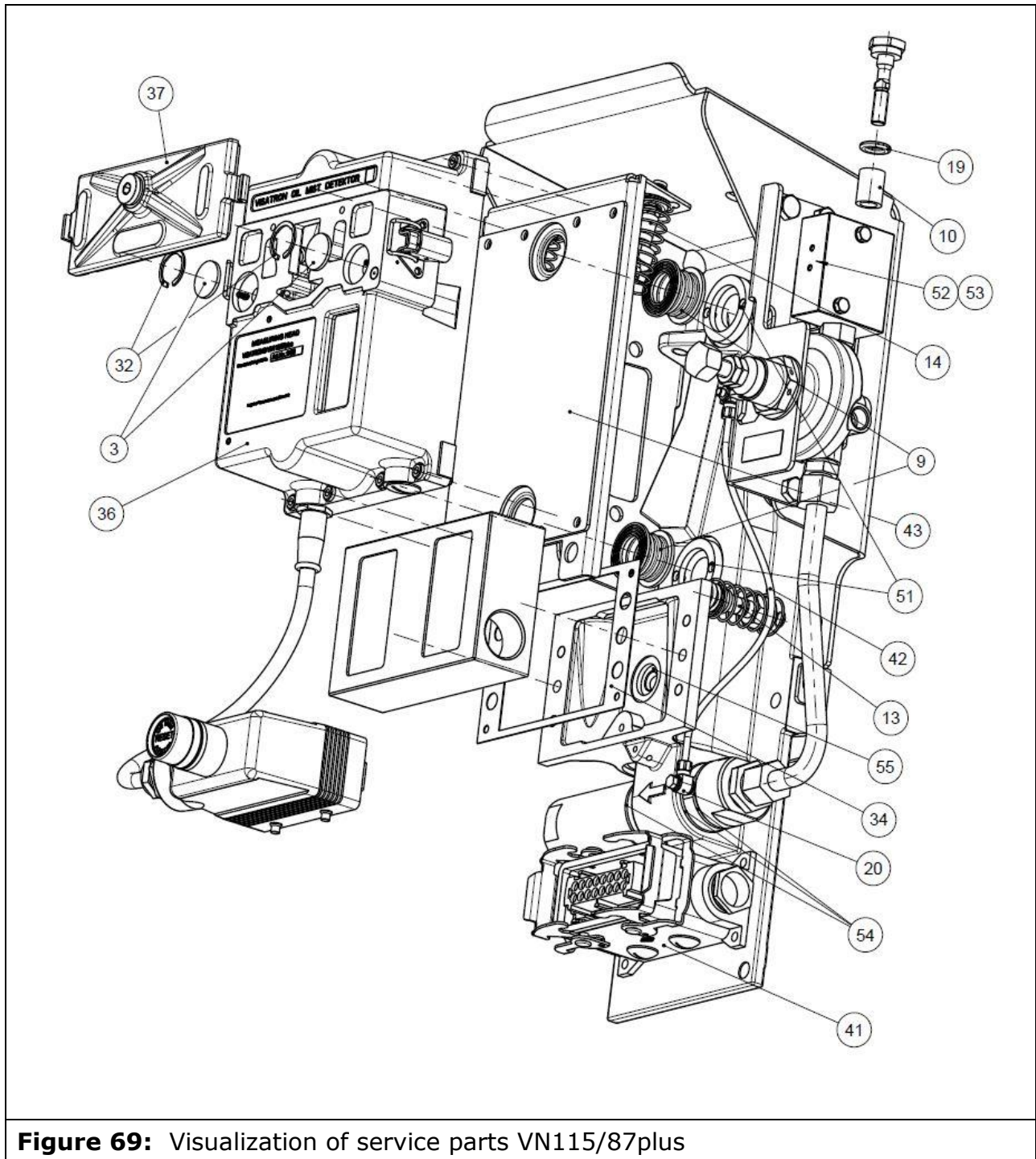


Item	Description	Quantity	For spares
01	U-pipe manometer	1	200548 / 10046
02	Manual series VN87 in English	1	260061
03	Scavenging air filters	6	365197 / 10042
04	Sealing for oil draining valve box	1	360132 / 10406
05	Fuse 2A semi time lag	10	436513 / 10043
06	Screwdriver 3 mm	1	190143 / 10038
07	Hex key 5 mm L-shape	1	190138 / 10044
08	Rubber plugs for unused valve box connections	3	360194 / 10412
09	Flexible bellows of suction channels	2	365193 / 10023
10	Air filter for pressure regulator unit	1	365206 / 10002
11	Sealing for oil draining in connection box VN115	1	360136 / 10206
12	Clamp plate VN215 valve box connection	2	350001 / 10409
13	Suspension elements bottom	2	200212
14	Suspension elements top	2	200211
15	Manometer adapter for siphon block VN180	1	270502
16	Bottle with slacked water	1	270089 / 10040
17	Bottle with cleaning fluid	1	See page 63
18	Sealing for suction channel in valve box	2	360133 / 10407
19	Service kit O-ring pressure regulator unit	1	270610
20	Service kit air supply	1	270609
21	Manual series VN87plus in English	1	180062 / 11078
22	Philips screwdriver	1	190053
23	Screwdriver 4 mm	1	190046 / 10157
24	Circlip pliers for Seeger rings	1	190146 / 10048
25	Hex key 4 mm with handle bar	1	190052
26	Hex key 6 mm L-shape	1	190206 / 10047
27	Double jaw wrench 14/17 mm	1	190050 / 10356
28	7mm combination wrench	1	190061
29	Rubber plate for VN215 valve box connection	2	360079 / 10411
30	Manometer adapter for control cover	1	270493 / 10053
31	Cleaning needle	1	190003 / 10135
32	Circlip for scavenging air filter	4	365198 / 10041
33	Cotton sticks to clean IR-filters	5	452176 / 10036
34	Gasket for valve box	1	330721 / 10405
35	Service box VN87plus content list	1	180506

**Table 12:** Contents of optional service box series VN87plus 150993



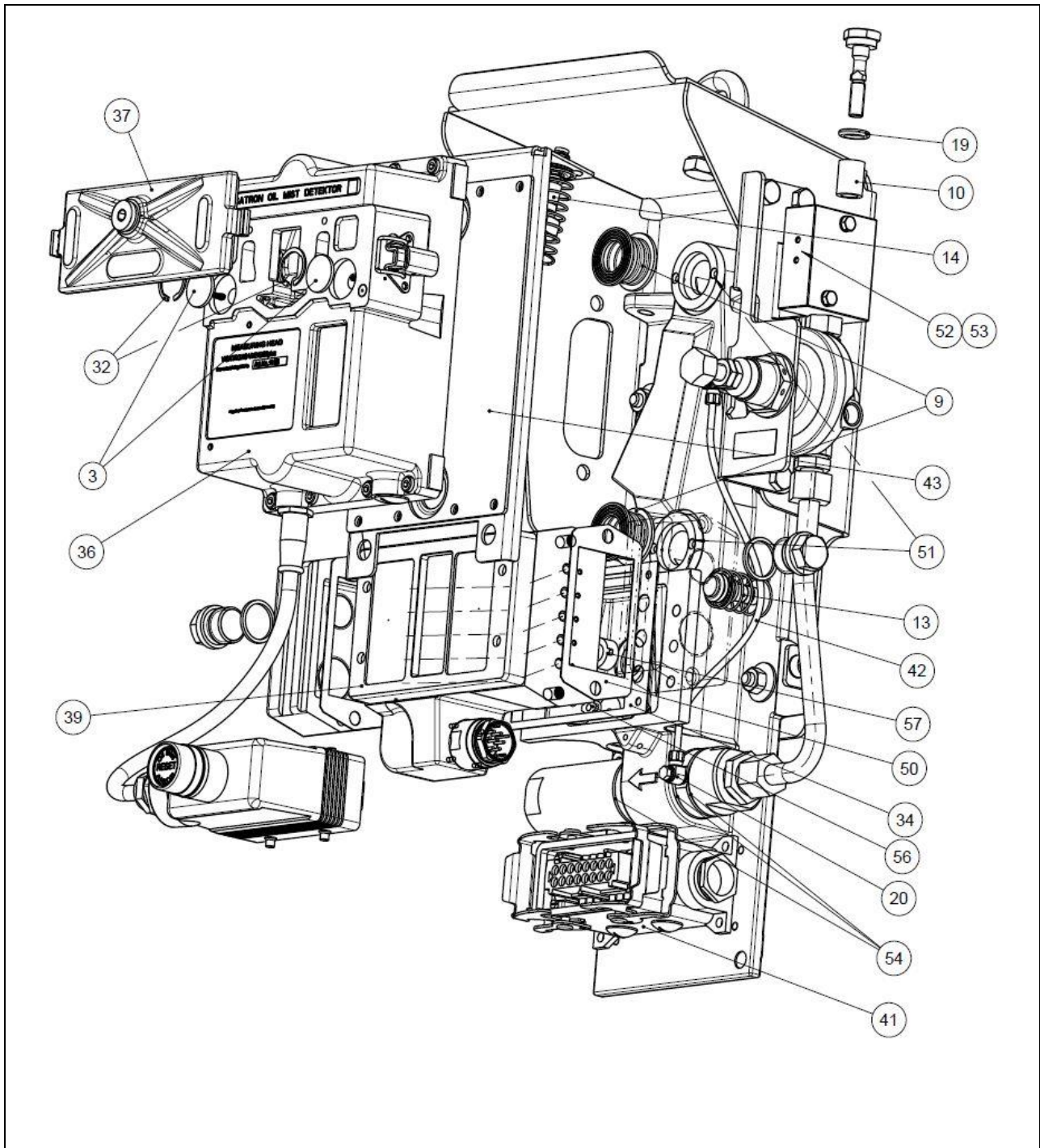




**Figure 69:** Visualization of service parts VN115/87plus

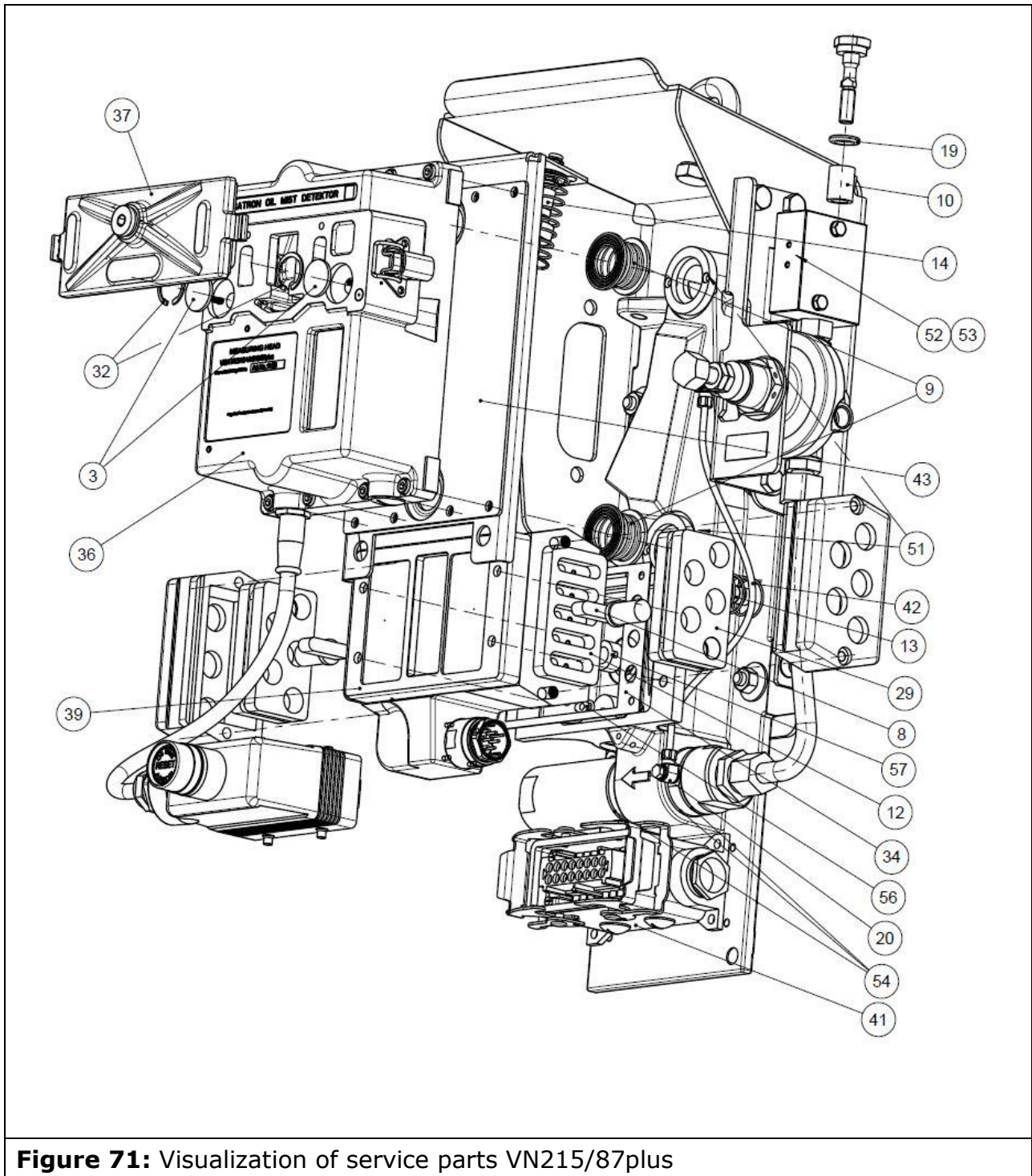






**Figure 70:** Visualization of service parts VN116/87plus





**Figure 71:** Visualization of service parts VN215/87plus



8.3 Optional Commissioning Box

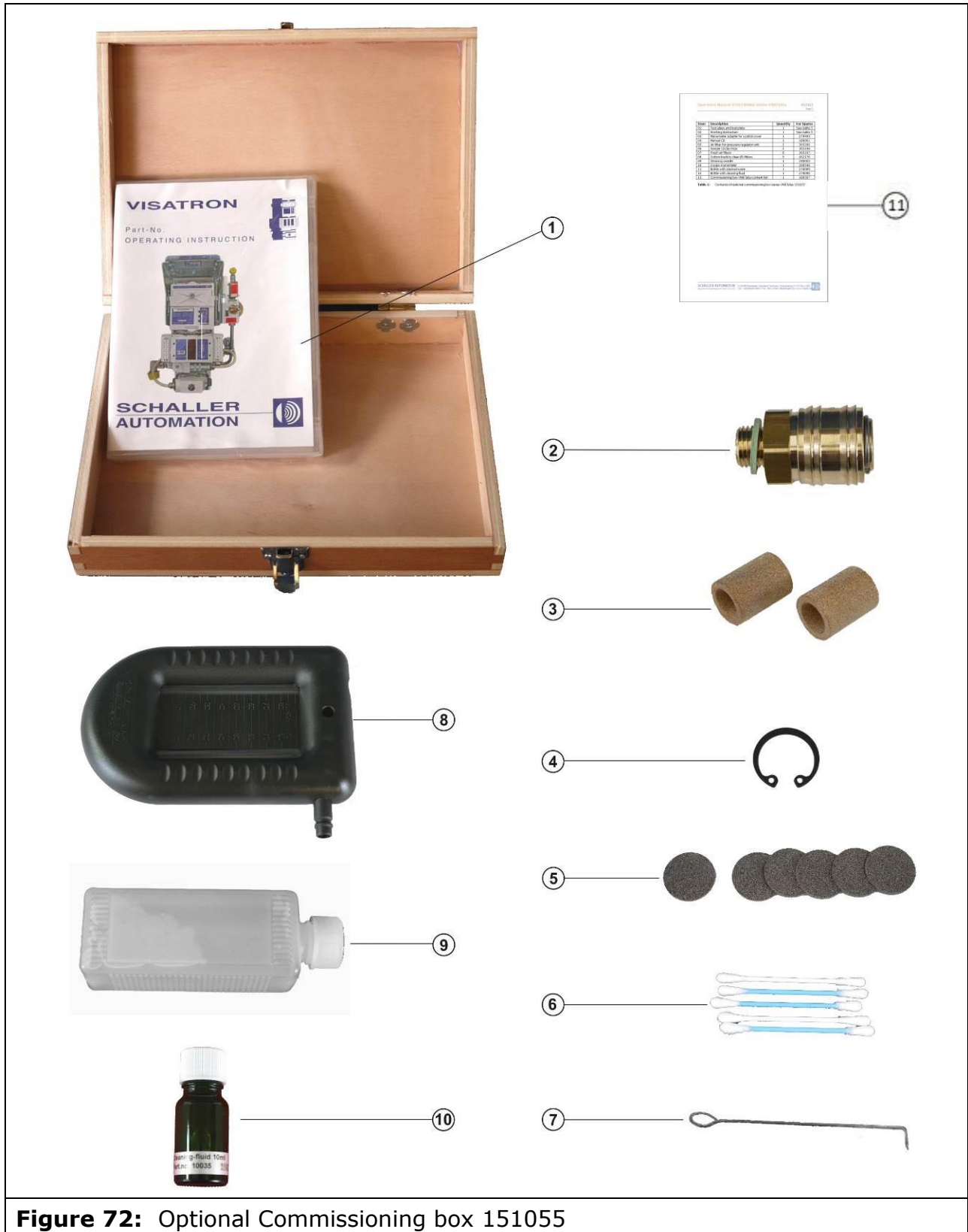


Figure 72: Optional Commissioning box 151055



Item	Description	Quantity	For Spares
01	Manual VN87plus englisch DVD-Form	1	180062 / 11078
02	Manometer adapter for control cover	1	270493 / 10053
03	Air filter for pressure regulator unit	2	365206 / 10002
04	Circlip for scavenging air filter	2	365198 / 10041
05	Scavenging air filters	6	365197 / 10042
08	Cotton sticks to clean IR-filters	5	452176 / 10036
07	Cleaning needle	1	190003 / 10135
08	U-pipe manometer	1	200548 / 10046
09	Bottle with slacked water	1	270089 / 10040
10	Bottle with cleaning fluid	1	See page 63
11	Commissioning box VN87plus content list	1	180507

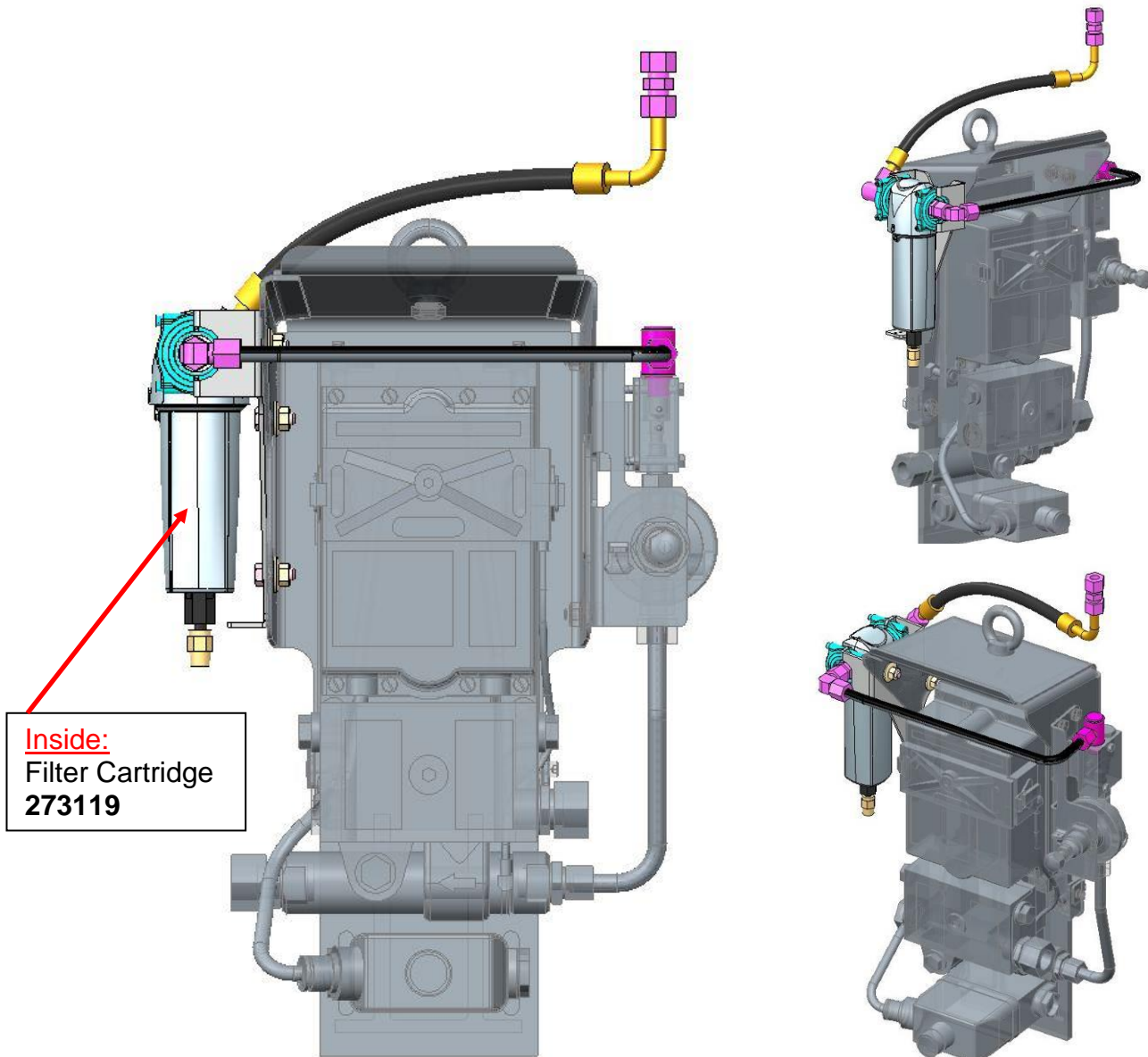
**Table 13:** Contents of optional commissioning box series VN87plus 151055





8.4 Optional Driving Air Conditioning (Part No. 272213)

VISATRON VN/87plus



**Inside:**  
Filter Cartridge  
273119

- For longer lasting air filter lifetime
- Longer TBO
- Makes independent of onboard air quality
- Easy retrofit

As an Option:

- Automatic de-oiling/-watering

VISATRON Oil Mist Detection systems of VN/87plus series are known as being reliable and trustworthy safety systems to protect your engine from crankcase explosions.

Nevertheless, in order to reduce maintenance cost and to ensure a maximum availability time, some upgrade kits are available.

In case of a non-optimal driving air quality to the oil mist detector, this kit may help you getting rid of failing OMD measuring heads, being indicated eg. by failure LED No. 14, negative pressure/airflow to low.

It helps you also avoiding trouble with clogged air filters in measuring head and pressure reducer.



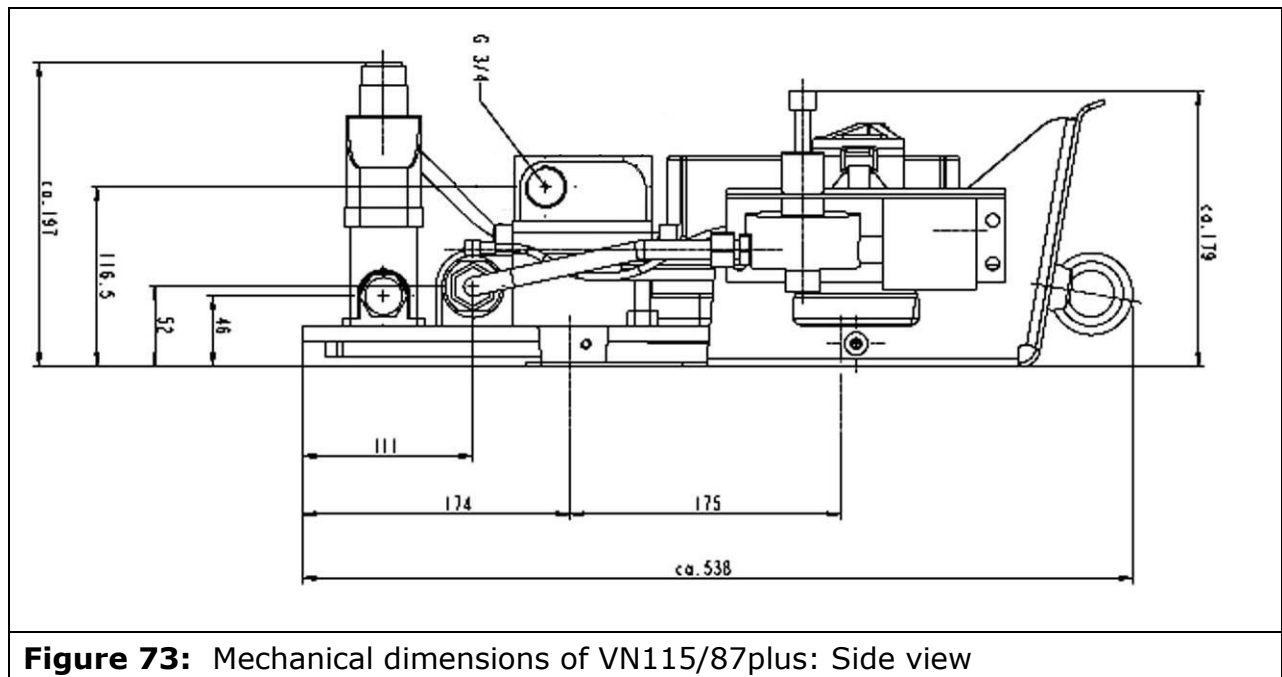
## 9 Technical data

<b>Mechanical data</b>	
Dimensions	See drawings (Figure 73 to Figure 78)
Weight	VN115/87plus 7.5 kg VN116/87plus 9.4 kg VN215/87plus 9.6 kg
Display	LED-bar with 14 LED's 1 green Ready LED 1 red High Oil Mist Alarm LED 1 red Test LED
Suction pipes	VN115/87plus $\varnothing$ 22 x 2 x max. 9m VN116/87plus $\varnothing$ 22 x 2 x max. 9m VN215/87plus $\varnothing$ 14 x 2 x max. 9m
Pipe connections	VN115/87plus 2 x G3/4 VN116/87plus 2 x G1/2 or G3/4 VN215/87plus 10 x $\varnothing$ 14
Venturi injector connections	In NTP/BSP/G1/2A Out NTP/BSP/G3/4A
Pressure reducer connections	In NTP/BSP/G1/4A Out NTP/BSP/G1/4A
<b>Electrical data</b>	
Power supply	18 Volts – 31.2 Volts DC, max. 2A
Nominal voltage	24 Volts DC
Relay Outputs	2 x 'High Oil Mist Alarm' 1 x 'Ready' 1 x 'Oil Mist Pre-Alarm' (max. 60 Volts DC, 1A)
Cable entry	2 x M25
Communication interface to monitoring device	2 wire RS485, galvanically isolated (opt. 4-20 mA, galvanically isolated)
Communication cable recommendation	LAPPKABEL UNITRONIC-FD CP (TP) plus UL-CSA, 2 x 2 x AWG20, max 400 m length, 7.5-10.0mm $\varnothing$
<b>Air data</b>	
Air pressure	Pressure reducer inlet 2 – 15 bar Air-jet pump inlet max. 500mbar

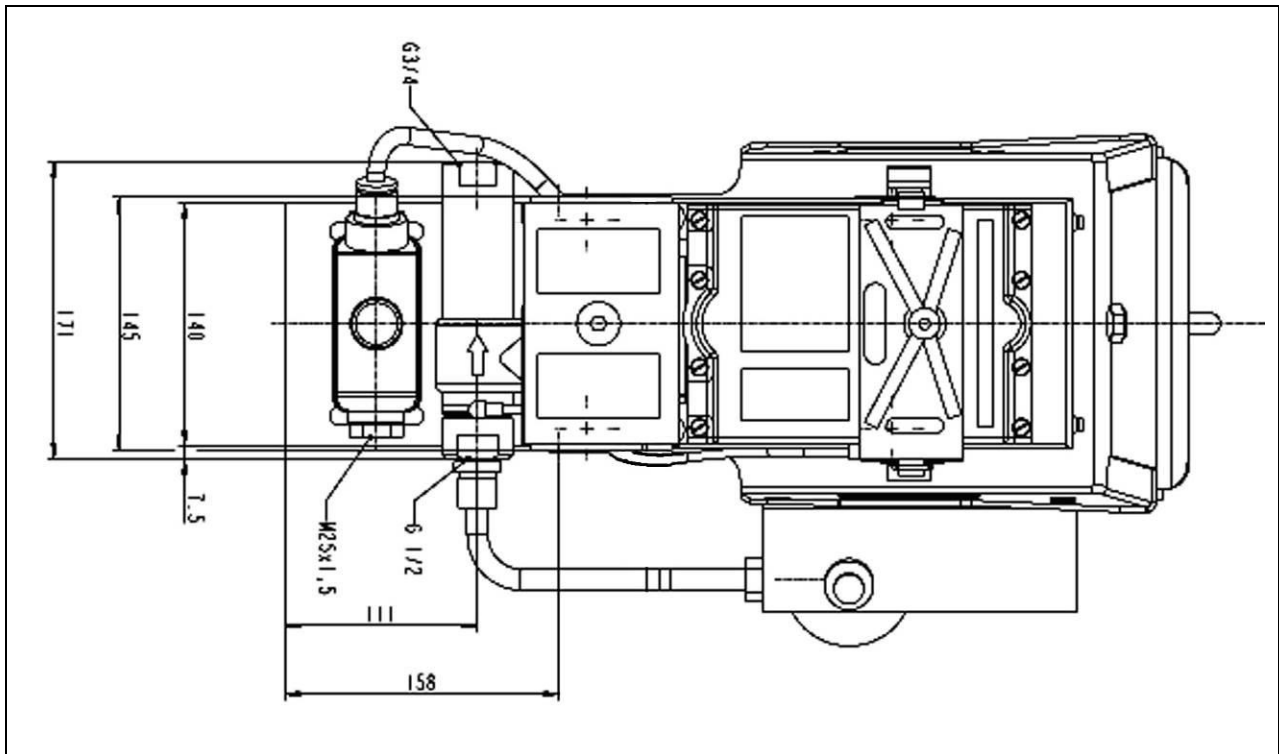


Air consumption	Depends on the suction system (max. 2.5 m <sup>3</sup> /h)
Negative pressure in measuring head	- 60mmWC or - 6 mbar
Air quality	ISO8573-1:2010 - "6-4-4"
<b>Environmental conditions</b>	
Operating temperature	0 - +70 °C
Storage temperature	-25 - +80 °C
Max. vibrations	5Hz - 25Hz: 1.6mm peak 25Hz - 300Hz: 40m/s <sup>2</sup> peak
Relative humidity	up to 95%
Protection class	IP54
<b>Approval of classes</b>	
	Type approved for closed areas, designed for installation on combustion engines, environmental category D (GL), IACS UR M67 conform, list of type approvals see <a href="http://www.schaller.de">www.schaller.de</a>

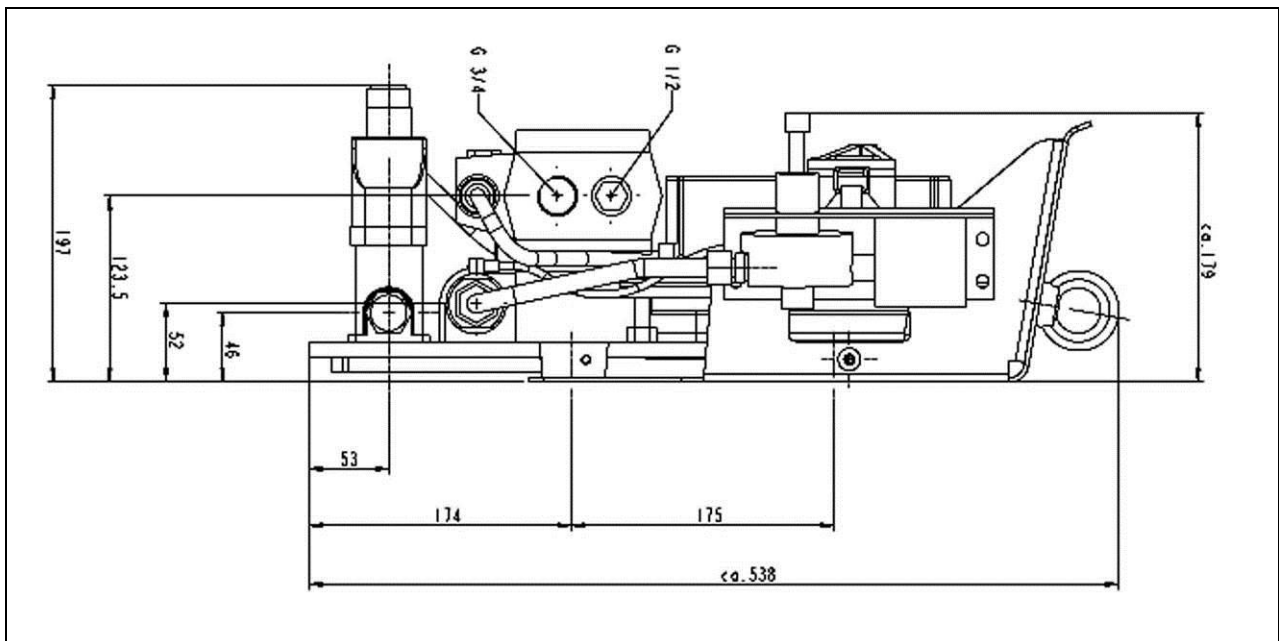
**Table 14:** Technical data





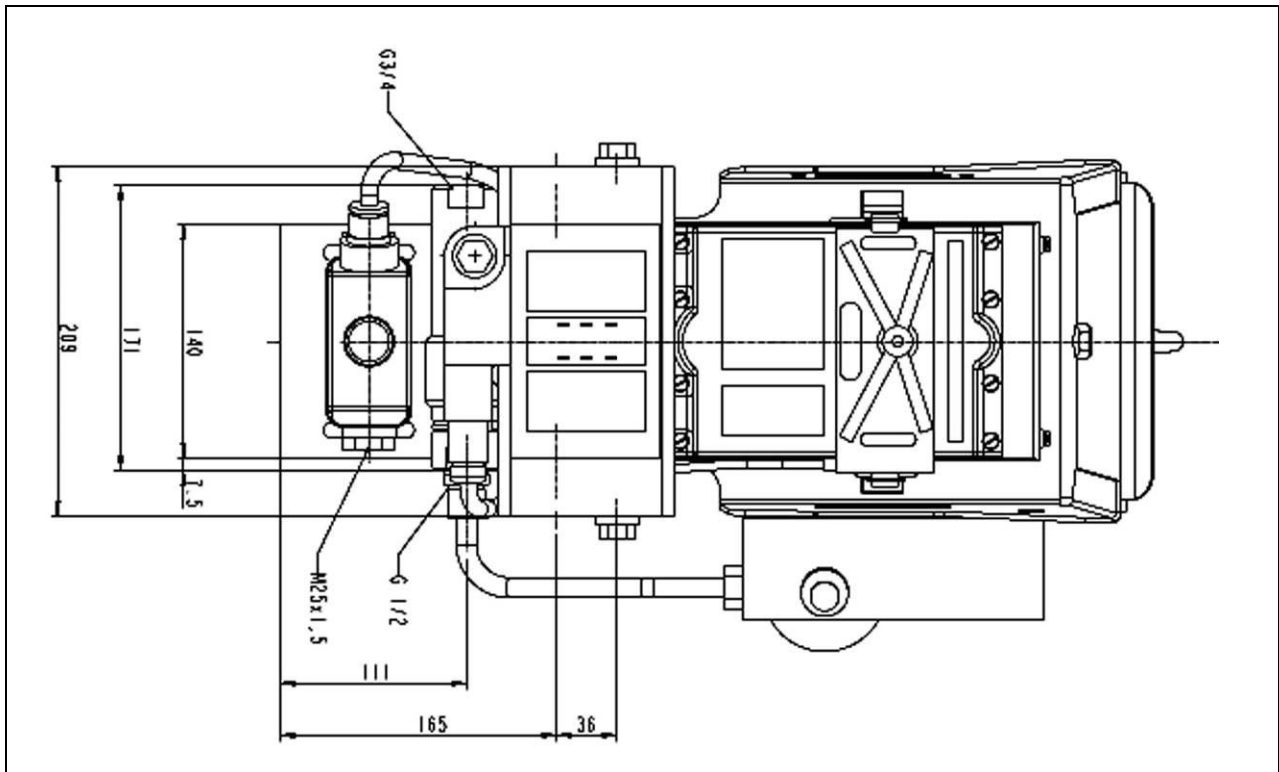


**Figure 74:** Mechanical dimensions of VN115/87plus: Top view

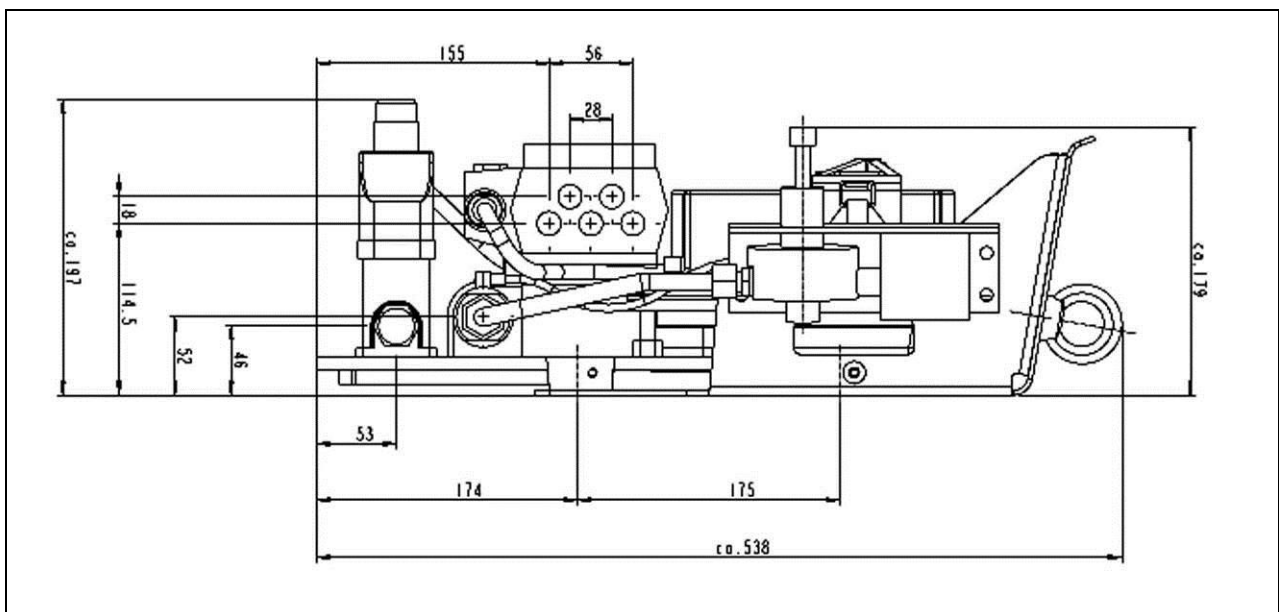


**Figure 75:** Mechanical dimensions of VN116/87plus: Side view



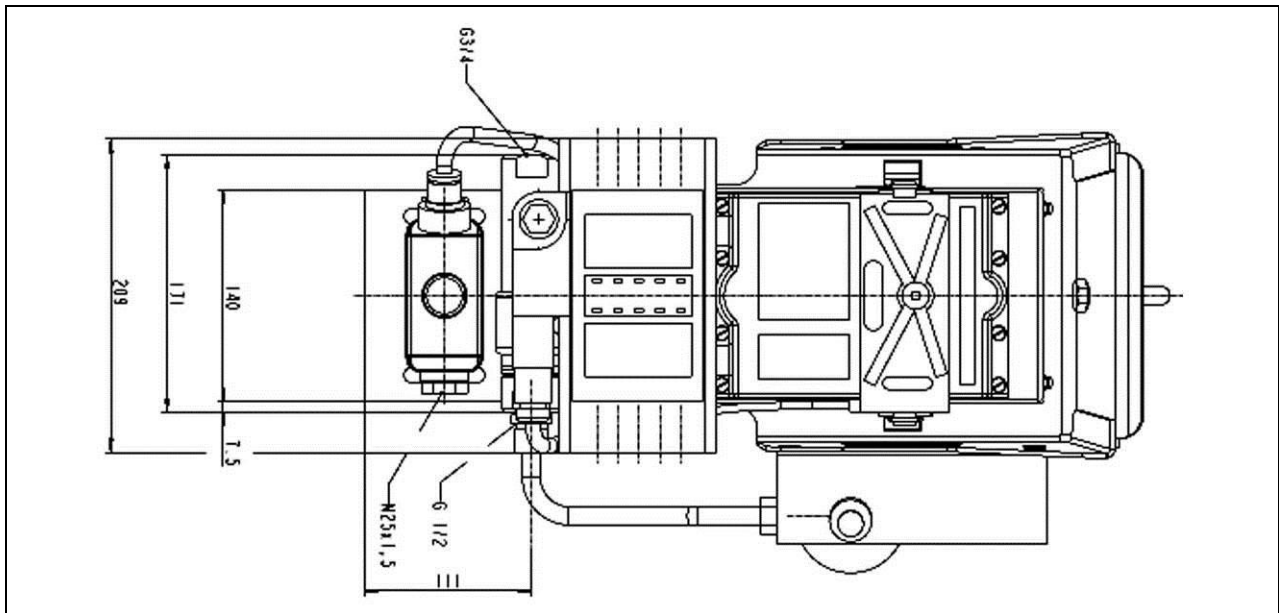


**Figure 76:** Mechanical dimensions of VN116/87plus: Top view

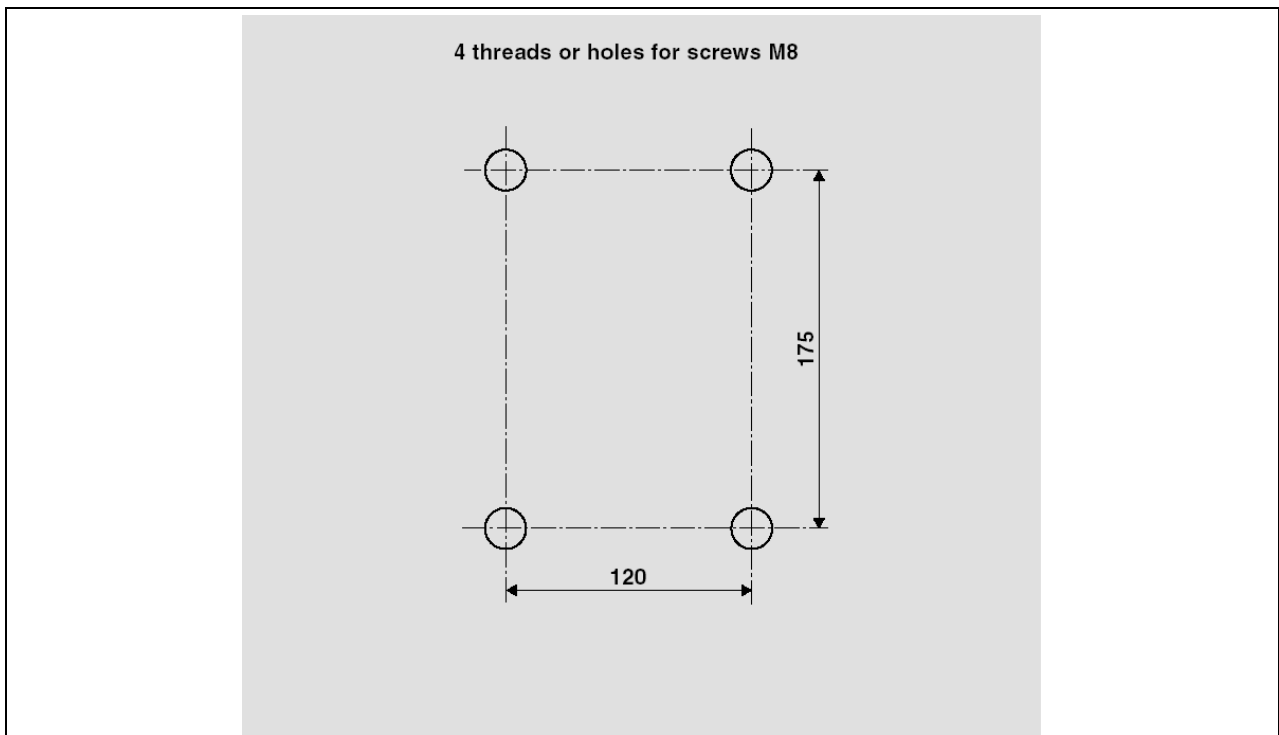


**Figure 77:** Mechanical dimensions of VN215/87plus: Side view





**Figure 78:** Mechanical dimensions of VN215/87plus: Top view



**Figure 79:** Drilling template of the OMD base plate



**10 Service Partners**

Schaller Automation maintains a worldwide network of service partners in following countries:

<b>Argentina</b>	<b>Kuwait</b>
<b>Australia</b>	<b>Latvia</b>
<b>Bahrain</b>	<b>Lithuania</b>
<b>Belgium</b>	<b>Mauritania</b>
<b>Belize</b>	<b>Mexico</b>
<b>Bolivia</b>	<b>Morocco</b>
<b>Brazil</b>	<b>Netherlands</b>
<b>Canada</b>	<b>Nicaragua</b>
<b>Cape Verde Islands</b>	<b>Norway</b>
<b>Caribbean Islands</b>	<b>Oman</b>
<b>Chile</b>	<b>Panama</b>
<b>Colombia</b>	<b>Peru</b>
<b>Costa Rica</b>	<b>Philippines</b>
<b>Denmark</b>	<b>Poland</b>
<b>Ecuador</b>	<b>Portugal</b>
<b>El Salvador</b>	<b>Qatar</b>
<b>Estonia</b>	<b>Saudi Arabia</b>
<b>France</b>	<b>Senegal</b>
<b>Germany</b>	<b>Singapore</b>
<b>Greece</b>	<b>Spain</b>
<b>Guatemala</b>	<b>Sweden</b>
<b>Honduras</b>	<b>Taiwan</b>
<b>Iceland</b>	<b>Turkey</b>
<b>India</b>	<b>United Arabian Emirates</b>
<b>Iran</b>	<b>United Kingdom</b>
<b>Ireland</b>	<b>United States of America</b>
<b>Italy</b>	
<b>Japan</b>	
<b>Korea</b>	

For an up-to-date list of our representatives including address and contact details please visit our website:

[www.schaller.de](http://www.schaller.de)

Or call our technical support center at the German headquarter:

**Tel. +49 6842 508 0**

